

USER MANUAL

Optical XO Series Dust Monitor Model EXO





Document information

Revision:	3
Publication date:	2024-11-20
Device series:	Optical XO
Applicable products:	EXO
Original language:	en-US

Trademarks

Microsoft Excel is a registered trademark of Microsoft Corporation.
Hastelloy is a registered trademark of Haynes International.

Legal disclaimer

Seller hereby disclaims any and all warranties and representations (express or implied, oral or written), including any and all implied warranties of merchantability or fitness for any purpose whether or not seller knows, or has reason to know, has been advised, or is otherwise in fact aware of any such purpose, whether alleged to arise by law, by reason of custom or usage in the trade, or by course of dealing or performance.

Purchaser understands and agrees that it shall be purchaser's sole responsibility to ensure that all products obtained from seller shall adhere to applicable laws, codes and standards within the territory of use. Purchaser absolves and holds seller harmless for any alleged violations of such local laws, codes, and standards within the territory of use.

Copyright

Subject to change without notice.
All rights reserved. ©2024 Sintrol.

Revision history

Manual updates

Revision	Date issued	Description
1	2021-02-16	First release
2	2022-03-21	<ul style="list-style-type: none"> Added new sections 4.6, 4.7, 4.7.1, 4.7.2, 6.4.8, 6.4.9, 7.6, 10.5.1, 10.5.4, 11.2, 12.4.6, 12.4.7, 12.4.8, 14.2, Appendix B. Updated sections 2.4, 3.2, 3.4, 3.5.2, 4.3, 4.5.1, 4.5.5, 6.4.4, 6.4.5, 6.4.6, 7.7.3, 8, 8.1, 8.3, 8.4, 8.5.1, 8.5.3, 10.3.4, 10.4, 10.5.3, 10.5.5, 10.5.6, 10.5.9, 12.4, 12.4.2, 12.4.4, 12.4.5, Appendix A. Moved sections 9.3, 14.1. Updated drawings and figures throughout the document. Terminology changes. Minor edits and revisions throughout the document.
3	2024-11-20	<ul style="list-style-type: none"> Updated standards and directives list (2.3).

Software updates

Revision	Date issued	Description	Type
21.11.01	2021-11	Version submitted for certification	

Firmware updates

Revision	Date issued	Description	Type
QAL_EXO_v3	2022-02	Version submitted for certification	

Hardware updates

Revision	Date issued	Description	Type
2	2022-02	Version submitted for certification	

Contents

1 About this manual	7		
1.1 Description of symbols.....	7	4.5.4 Reference check.....	35
1.2 Abbreviations.....	9	4.5.5 Manual span check	36
2 Safety	10	4.6 Periodic self-diagnostics	37
2.1 Warnings	10	4.7 Flow measurement.....	37
2.2 Intended use	11	4.7.1 Sampling flow measurement.....	37
2.3 Conformity to standards and directives .	12	4.7.2 Purge air flow measurement	37
2.4 Overview of device life cycle under		4.8 Potential influences on measurement	
EN 14181 standard.....	13	results	38
3 Product overview.....	15	4.8.1 Particle material.....	38
3.1 Product description.....	15	4.8.2 Particle size	38
3.1.1 Key properties.....	15	4.8.3 Relative humidity.....	38
3.1.2 Commissioning and parametrization		4.8.4 Ambient temperature.....	38
.....	16	4.8.5 Flow velocity	38
3.1.3 Installation	16	5 Transport and storage	39
3.1.4 User interface.....	16	5.1 Unpacking and inspection	39
3.2 Main components.....	17	5.2 Storage.....	39
3.3 Identification.....	23	5.3 Transport	40
3.4 Scope of delivery.....	24	6 Mechanical installation	41
3.5 Features and accessories	25	6.1 Safety precautions	41
3.5.1 Standard features	25	6.2 Installation location	42
3.5.2 Optional features and accessories... 25		6.2.1 Ambient environment	42
4 Functional description of sampling line	28	6.2.2 Location	42
4.1 Operating principle	28	6.2.3 Orientation.....	42
4.1.1 Scattered Light Value	28	6.2.4 Angle	42
4.2 Functional diagram of sampling line.....	28	6.2.5 Probe length	43
4.3 Measurement cycle.....	29	6.2.6 Duct pressure.....	43
4.4 Cleaning pulse function.....	30	6.3 Preconditions for installation	44
4.5 Optical XO sensor module	31	6.4 Installation	45
4.5.1 Structure and components	31	6.4.1 Mounting enclosure to mounting	
4.5.2 Normal operation.....	33	frame.....	45
4.5.3 Signal comparison check.....	34	6.4.2 Assembling process connection flange	
		47

6.4.3 Connecting sampling probe to enclosure.....	49	8.5.5 Config Page	85
6.4.4 Installing optical XO sensor module.....	51	9 Commissioning and system setup.....	86
6.4.5 Installing dust monitor to stack	54	9.1 Setting up user interface.....	86
6.4.6 Installing sample air blower	57	9.1.1 Local touchscreen display	86
6.4.7 Connecting purge air supply	61	9.1.2 Using Remote Display Control software (CERHOST).....	87
6.4.8 Installing weather protection roof...61		9.2 Logging in as Service level user.....	88
6.4.9 Installing fan heater and thermostat	63	9.3 Calibration.....	89
7 Electrical installation	64	10 Operation	90
7.1 Electrical safety	64	10.1 Main power switch	90
7.2 Cable types	65	10.1.1 Powering up	90
7.3 Power sockets	65	10.1.2 Powering down	90
7.3.1 Power supply socket	66	10.2 Starting and stopping sampling	90
7.3.2 Power outlet for sample air blower	66	10.3 Device functions.....	91
7.4 Connections on sampling probe	67	10.3.1 Automatic stepper calibration.....	91
7.5 Connections on sensor module.....	69	10.3.2 Zero and full range check.....	92
7.6 Connections on fan heater and thermostat	71	10.3.3 Signal comparison check.....	94
7.7 Analog and digital outputs	72	10.3.4 Manual span check	95
7.7.1 Connection box	72	10.4 Restarting user interface	98
7.7.2 Connecting analog mA output	73	10.5 Parameters and settings	99
7.7.3 Connecting digital outputs.....	74	10.5.1 Continue sampling after power failure	99
8 User interface	77	10.5.2 Flue gas setpoint	99
8.1 MAIN view	77	10.5.3 Sampling start setpoint.....	99
8.2 Sampling view	78	10.5.4 Flow control	100
8.3 Optical view.....	79	10.5.5 Cleaning pulse interval.....	100
8.4 Alarms view	80	10.5.6 Compressor settings	100
8.5 Settings view and user access levels.....	81	10.5.7 Maximum heater temperature....	101
8.5.1 User access levels.....	81	10.5.8 Averaging time.....	101
8.5.2 Logging in	82	10.5.9 Calibration parameters	102
8.5.3 Sampling settings	83	10.5.10 mA output signal scaling	103
8.5.4 XO Settings	84	10.5.11 Fiber signal max REF	104
		10.6 Data logging	104











10.6.1 Enabling data logging.....	105	14 Technical data	130
11 Troubleshooting.....	106	14.1 Dimensions	130
11.1 Error messages.....	106	14.2 Clearances.....	132
11.1.1 ZERO&REF check error.....	106	14.3 Specifications	133
11.1.2 Stepper1 and stepper2 homing error	107	Appendix A: ISO 9001 certificate	134
11.1.3 CSV-File writing error.....	107	Appendix B: Electrical schematics.....	135
11.1.4 Light source or optical fiber failure	107	Notes.....	146
11.1.5 Check comparison signal.....	108		
11.2 Using digital outputs	108		
11.3 No output signal.....	110		
11.4 Invalid output signal.....	111		
12 Maintenance and inspection	112		
12.1 Safety precautions	112		
12.2 Maintenance and inspection interval	113		
12.3 Cleaning supplies	114		
12.4 Maintenance procedures.....	115		
12.4.1 Filter locations.....	115		
12.4.2 Optical XO sensor module	116		
12.4.3 Sampling probe	118		
12.4.4 Ejector chamber.....	120		
12.4.5 Internal piping of the sampling line	123		
12.4.6 Operation of sampling flow measurement.....	126		
12.4.7 Sampling flow measurement hoses	126		
12.4.8 Operation of purge air flow measurement.....	127		
12.5 Returns.....	128		
13 Recycling and disposal	129		
13.1 Packaging	129		
13.2 Device.....	129		

1 About this manual

This user manual contains the installation, commissioning, operating and maintenance instructions for optical XO series extractive dust monitor model EXO. Read this manual carefully before using the device. This manual is an important part of the product, and it must always be available for reference to all personnel installing, commissioning, operating or performing maintenance on the device. In case the manual is lost or damaged, request a new copy from the manufacturer or an authorized distributor.

1.1 Description of symbols

These symbols are used to alert you to any potential personal injury hazards, and to provide information on how to avoid them. Follow all safety messages that use these symbols to avoid possible injury or death. Symbols that provide additional information about using and handling the product are also described here.

Symbol	Description
	General warning symbol.
	Hot surface.
	Electric hazard.
	Toxic hazard.
	Explosion hazard.
	Important or useful information related to installing, maintaining or operating the device.
	Read the user manual before doing a procedure or operating the device.
	Wear a hard hat

Symbol

Description



Wear hearing protection



Wear protective gloves.



Wear protective glasses.



Wear protective overalls.



Wear a welding mask.



Wear respiratory protection.



CE marking indicates that the device has been designed and manufactured to meet all applicable health, safety and environmental protection standards required for products sold in the European Union.



Electronic devices that are marked with this symbol must not be disposed of with general waste. If a defective or broken-down device cannot be repaired, it must be recycled and disposed of in accordance with WEEE directive (2012/19/EU) or other applicable local regulations.



This symbol indicates waste material that must be recycled.

1.2 Abbreviations

Abbreviation	Explanation
AST	Annual surveillance test
QAL	Quality assurance level
RH	Relative humidity
SLV	Scattered light value
SRM	Standard reference method
TSP	Total suspended particles
VPN	Virtual private network

2 Safety



**Read this chapter carefully before handling the device in any way.
In addition, read all safety notes before work steps and other instructions.**

Only trained and qualified personnel can install, commission, operate and perform maintenance on the device. All personnel must read and understand this manual and follow its instructions accurately. Failure to follow the safety instructions and safety precautions can result in serious injury or death.

If you encounter any unexpected situations during the intended use of the device that are not described in this manual, contact the manufacturer or an authorized distributor.

In addition to the safety instructions described in this manual, the personnel using the device must follow all applicable country- and industry-specific safety standards and regulations.

2.1 Warnings



DANGER!

“DANGER” indicates a hazard with a high level of risk, which will result in death or serious injury if not avoided.



WARNING!

“WARNING” indicates a hazard with a medium level of risk, which can result in death or serious injury if not avoided.



CAUTION!

“CAUTION” indicates a hazard with a low level of risk, which can result in minor or moderate injury if not avoided.

NOTICE

“NOTICE” indicates a situation with a risk of equipment damage.

2.2 Intended use

DANGER!



Explosion hazard

The device is not UL/CSA or IECEx/ATEX certified. Do not use the device in potentially explosive atmospheres.

WARNING!



Use in critical applications

Improper use in critical applications can lead to hazardous situations or have severe adverse health effects. Such critical applications include, but are not limited to:

- Health protection
- Emission monitoring
- Process control
- Fire and explosion prevention



Wear appropriate protective gloves at all times when installing the device.

This device is designed for continuous measuring of total suspended particles (TSP) inside small and medium industrial stacks in wet conditions, for example after wet scrubbers or in condensing environments. The intended use is as described in this user manual. Any other use is considered improper and can result in injury or equipment damage.



The manufacturer or distributor cannot be held liable for any damage, injury or financial loss resulting from improper use.

The device must not be modified or repaired in any way that is not specifically described in this manual. Do not perform any mechanical or electrical repairs without contacting the manufacturer or an authorized service center or distributor. Only original Sintrol parts can be used for repairs. If third-party spare parts are used, the manufacturer cannot guarantee safe operation of the device.

Before installing and commissioning the device, carefully inspect it for any damage or defects. Do not use the device if it is damaged, or if the power supply is defective. Return damaged device to the manufacturer or an authorized distributor.

Non-compliance with any of these conditions immediately voids the warranty, and the manufacturer's responsibility no longer applies.

Many factors can affect the operation of the dust monitoring system. These factors can include, for example, dust particle size, dust material, the design of the stacks, pipes or ducts that the dust monitor is installed on, and operator error. Because of this, an industry specialist must evaluate and approve the suitability of Sintrol products for any given dust monitoring system. This is particularly true when the instruments are only a component in a larger monitoring system, or when they are used in critical applications.

2.3 Conformity to standards and directives

This device has been designed and manufactured to comply with the requirements of ISO 9001:2015 standard related to quality management. See **Appendix A** for ISO 9001 certificate.

This device has been designed and manufactured to comply with the following standards and directives:

- EN 61010-1: 2011/A1:2019 Safety requirements for electrical equipment for measurement, control, and laboratory use - Part 1: General requirements
- EN 61326-1: 2020 Electromagnetic Compatibility EMC

2.4 Overview of device life cycle under EN 14181 standard

After unpacking the device, it must be handled throughout its life cycle in the following way:

Installation and commissioning

1 Installation

- Choose the appropriate installation location and install the device mechanically.
- Follow the specifications set out in standard EN 15259
- See chapter **Mechanical installation** for installation instructions. In case of conflict, follow instructions set out in standard EN 15259.
- Make all necessary electrical connections. See chapter **Electrical installation** for instructions.
- Commission the device as instructed in chapter **Commissioning and system setup**.

2 Functional checks during commissioning

- Power on the device and log in to the user interface with the appropriate user level. If necessary, set up Remote Display Control software (CERHOST) to control the device on an external computer.
- Self-diagnostics interval can be adjusted on the user interface when logged in as Admin user. Default factory-set interval is 24 hours.
- Perform functional check by examining the zero/span values to ensure that the measurement response is correct. At this stage, examining the zero/span check values is sufficient for a functional check.
- You must perform these functional checks withing the maintenance interval before conducting annual surveillance test (AST) or QAL2.

3 QAL2 calibration

- Have an accredited testing institute perform calibration using standard reference method (SRM) as specified in standard EN 13284-1 or according to any applicable local regulations and reference methods.
- An accredited testing institute must perform QAL2 calibration according to the interval set out in any applicable local regulations and standards. Typical QAL2 interval is 3 to 5 years depending on the process conditions.
- You must ensure that functional checks and maintenance are done according to the manufacturer's instructions before conducting QAL2 or AST procedures.

Operation

4 QAL3 self-diagnostics

- QAL3 self-diagnosis ensures that there are no changes in the mA output scale and that the device continues to operate according to QAL2 calibration.
- Write down the mA values from one or two separate zero/span checks and store them for future reference. Compare these reference values

to the values of zero/span checks that are performed before QAL2 or AST to ensure there is no drift in zero and span points.

5 Functional tests during operation

- The device runs periodical self-diagnostic and cleaning functions to ensure that the sampling line and the optics inside the sensor module remain in good operating condition.
- Perform maintenance on the device according to the maintenance interval determined by the manufacturer. See chapter **Maintenance and inspection** for instructions.
- Examine the internal zero/span check values to ensure the measurement response is close to 0 mg/m³ / 4 mA during zero check and that the value matches the device-specific value measured by the manufacturer during span check. Compare the values to the reference mA values. Zero/span check interval is set during commissioning.

6 Annual surveillance test (AST)

- Have an accredited testing institute perform validation of the calibration function using standard reference method (SRM) as specified in standard EN 13284-1 or according to any applicable local regulations and reference methods.
- An accredited testing institute must perform AST once per year.
- You must ensure that functional checks and maintenance are done according to the manufacturer's instructions before conducting QAL2 or AST procedures.

7 Decommissioning

- When the device has reached the end of its life cycle, remove it from the process.
- Recycle and dispose of the device in accordance with WEEE directive (2012/19/EU) or other applicable local regulations.

End of life cycle

The above list outlines all major operation steps during the life cycle of the device. In addition, observe the following general notes:

- Use the device only as instructed in this user manual.
- If you encounter problems when using the device, see chapter **Troubleshooting**, or contact the manufacturer or an authorized distributor.
- If you relocate the device, repeat the complete installation and commissioning cycle as instructed in this user manual.

3 Product overview

3.1 Product description

The device is designed to continuously measure the concentration of dust particles inside industrial stacks. It is an ideal solution for emission monitoring in wet conditions, for example after wet scrubbers or in condensing environments.

EXO dust monitor consists of a heated sampling probe, optical XO sensor module and an integrated panel PC, which are housed in a weather-proof powder coated steel enclosure that is mounted on a frame. In a complete installation the probe is inserted inside a stack perpendicular to the airflow using a flange. An external sample air blower supplies air to an ejector chamber at the end of the sampling line, creating a suction that draws flue gas through the internal piping of the device and ejects it back into the stack.

During operation, the probe continuously extracts a gas sample, which is heated to vaporize any water droplets and moisture. The remaining particles are directed through the measurement chamber of the optical XO sensor module. Light from an LED is directed through the particle stream, which causes the light to scatter. A scattered light detector captures the scattered light and determines the particle concentration in the gas sample from the amount of scattered light. The underlying method is called “optical forward scattering”.

The device must be calibrated to the process conditions after installation using a standard reference method. The user interface displays the measurement results as mg/m³ and mA values.

For detailed technical data, see section **Specifications** in chapter **Technical data**.

3.1.1 Key properties

Table 1: Key properties

Enclosure:	Powder coated steel IP54
Probe length:	1 m (3.28 ft)
Probe material:	Stainless steel (316L), Optionally Hastelloy C276
Output signals:	<ul style="list-style-type: none"> • 2 × 8 Digital outputs, 24 V DC / 0.5 A • 4 ... 20 mA output • Ethernet TCP/IP for remote control • USB for data logging
Max. process temperature:	300 °C (572 °F)
Ambient temperature:	-40 ... 50 °C (-40 ... 122 °F)
Flow velocity:	5 ... 25 m/s (16.40 ... 82.02 ft/s)

3.1.2 Commissioning and parametrization

Controlling the device settings is simple using the integrated panel PC. There are three access levels with varying user rights for regular users, service personnel and admin users.

3.1.3 Installation

The sampling probe is equipped with a DN80/100 multi-purpose flange for connecting the device to the stack. The installation location must have a compatible counter flange. A rubber expansion joint with DN80/100 flanges is installed between the device and the stack to mitigate vibrations.

3.1.4 User interface

You can access and change the device settings and parameters locally with an integrated panel PC with touchscreen input. Alternatively, you can connect an external computer to the device with Ethernet cable and control the device using Remote Display Control software (CERHOST) on a laptop or desktop computer.

3.2 Main components

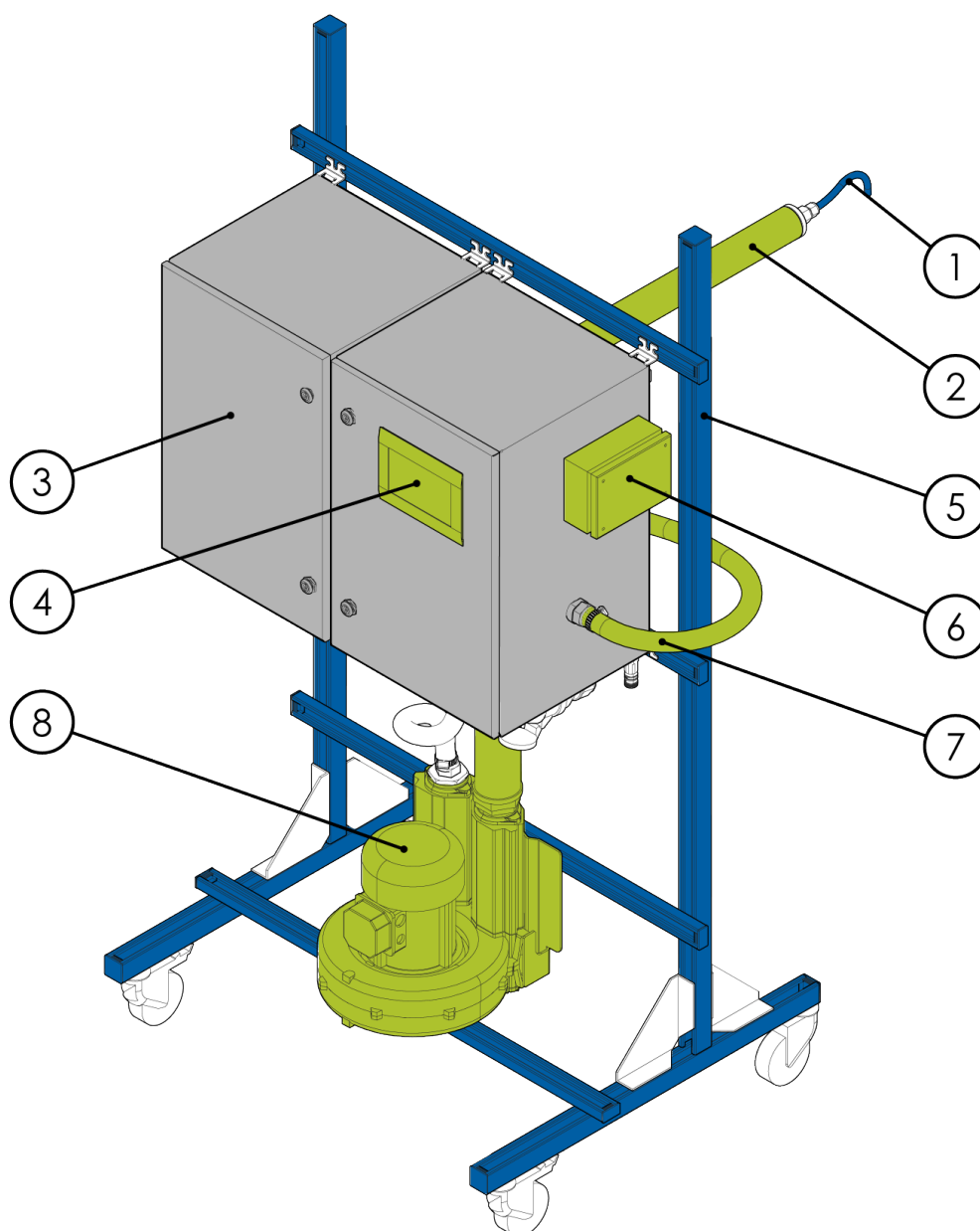

Figure 1: Overview of the major parts of EXO dust monitor, front side

① Sampling probe nozzle	⑤ Mounting frame
② Sampling probe	⑥ Connection box
③ Powder coated steel enclosure	⑦ Exhaust tube for return gas
④ Integrated panel PC	⑧ Sample air blower

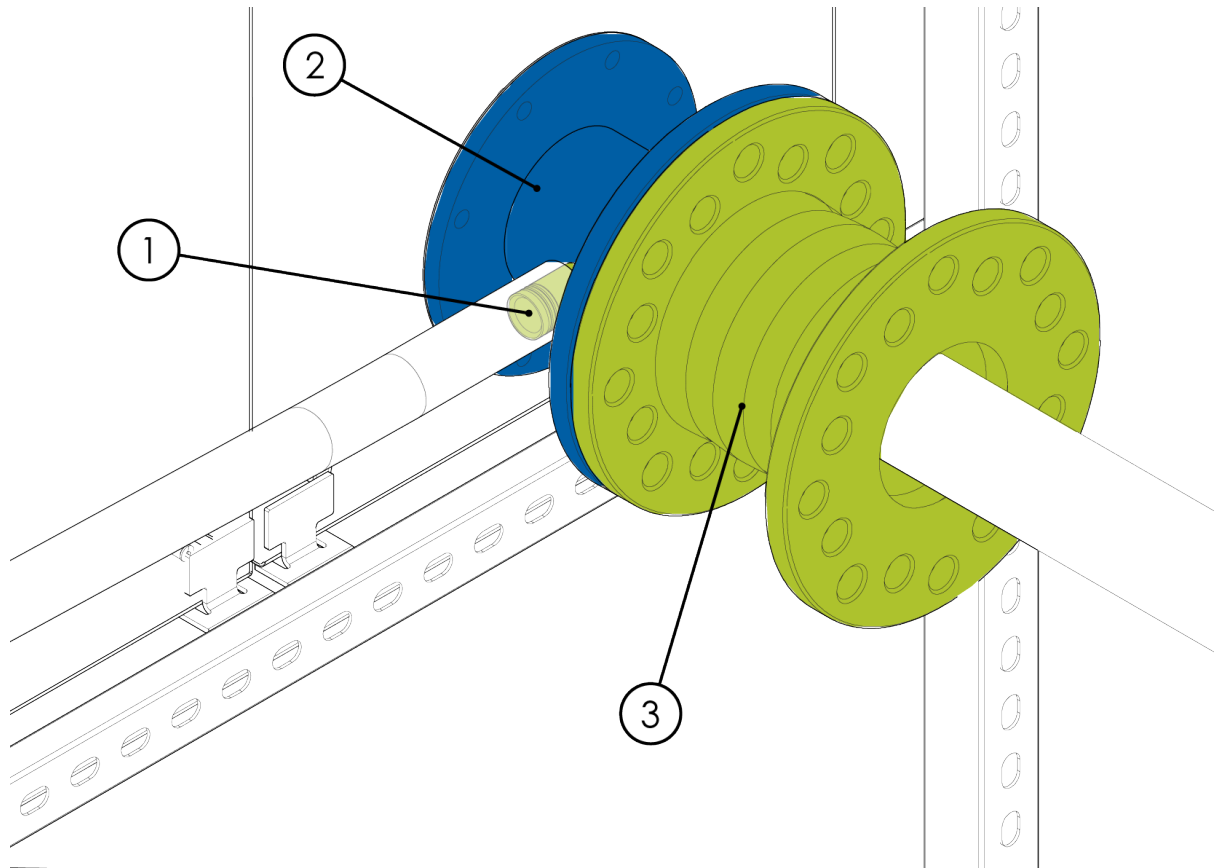

Figure 2: Overview of the major parts of EXO dust monitor, back side

- | | |
|---|---|
| ① | Sample return inlet |
| ② | Sampling probe connection with a flange for connecting the sampling probe to the enclosure and DN80/100 multi-purpose flange for process connection |
| ③ | Rubber expansion joint with DN80/100 flanges for process connection |

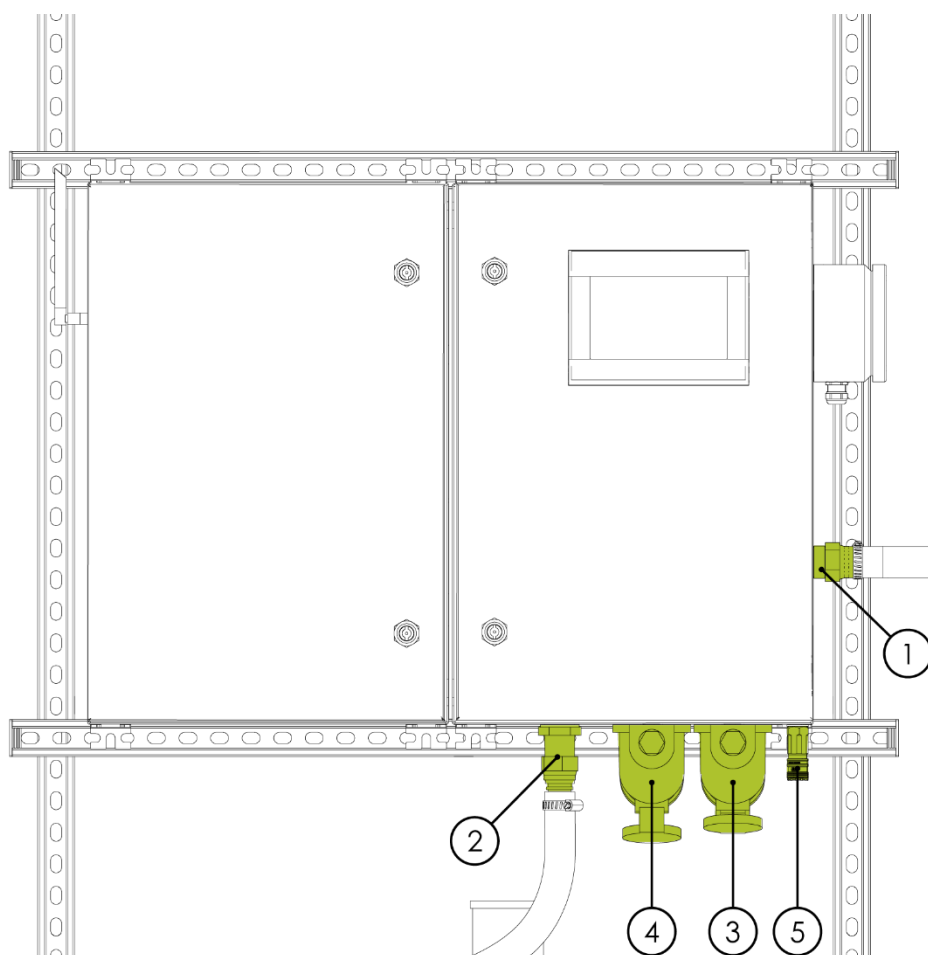

Figure 3: Connections on the enclosure

① Ejector chamber air outlet	④ Power outlet for sample air blower, female
② Sample air inlet	⑤ Process air connection for purge air
③ Power supply socket, male	

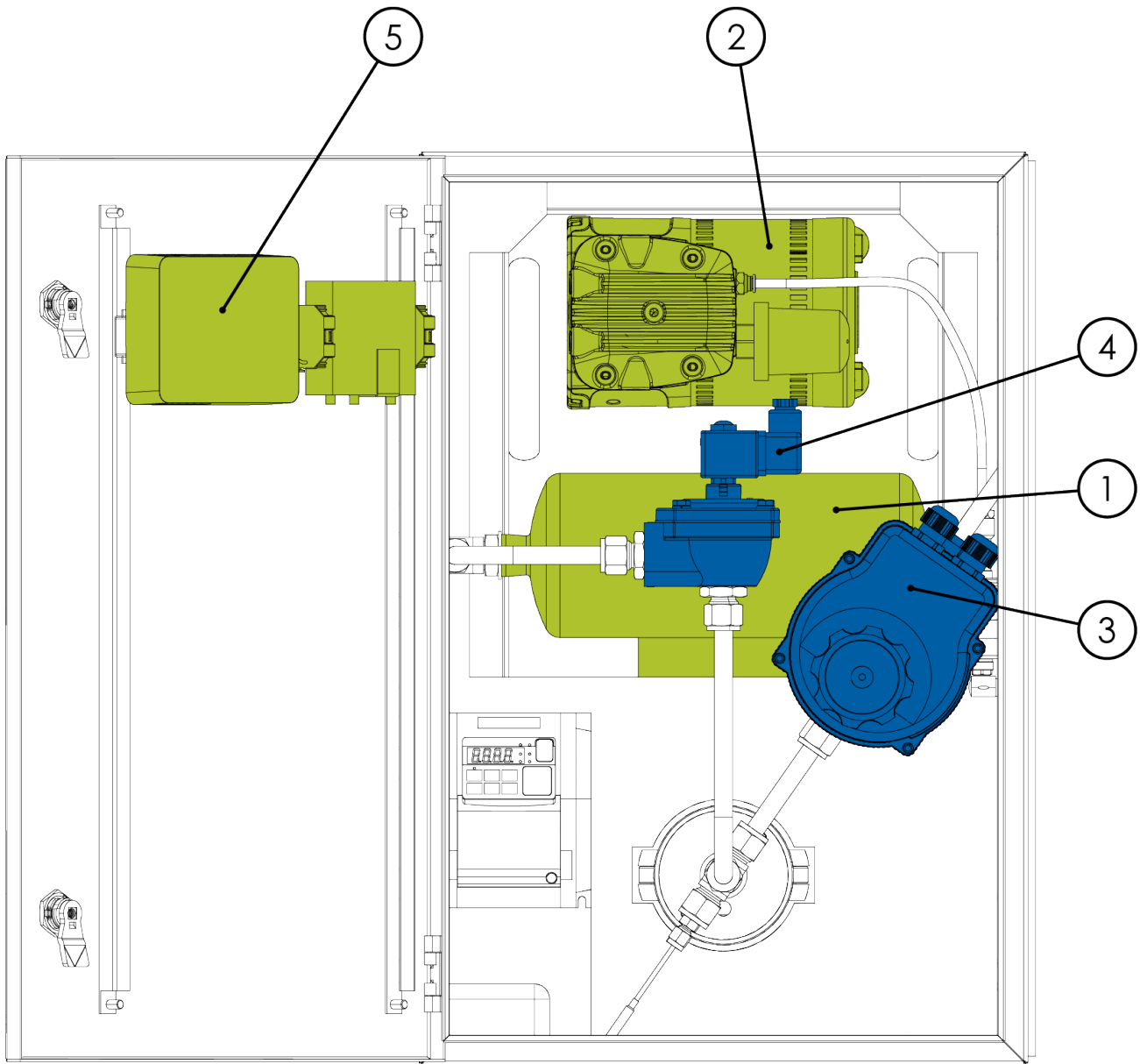

Figure 4: Major internal components of EXO dust monitor, left cabinet

- | | |
|-------------------|-------------------------|
| ① Pressure vessel | ④ Cleaning pulse valve |
| ② Compressor | ⑤ Remote access device* |
| ③ Flue gas valve | |

* As an additional service, the manufacturer can use the remote access device to monitor and control the device remotely through mobile network and VPN. Not included in a standard delivery.

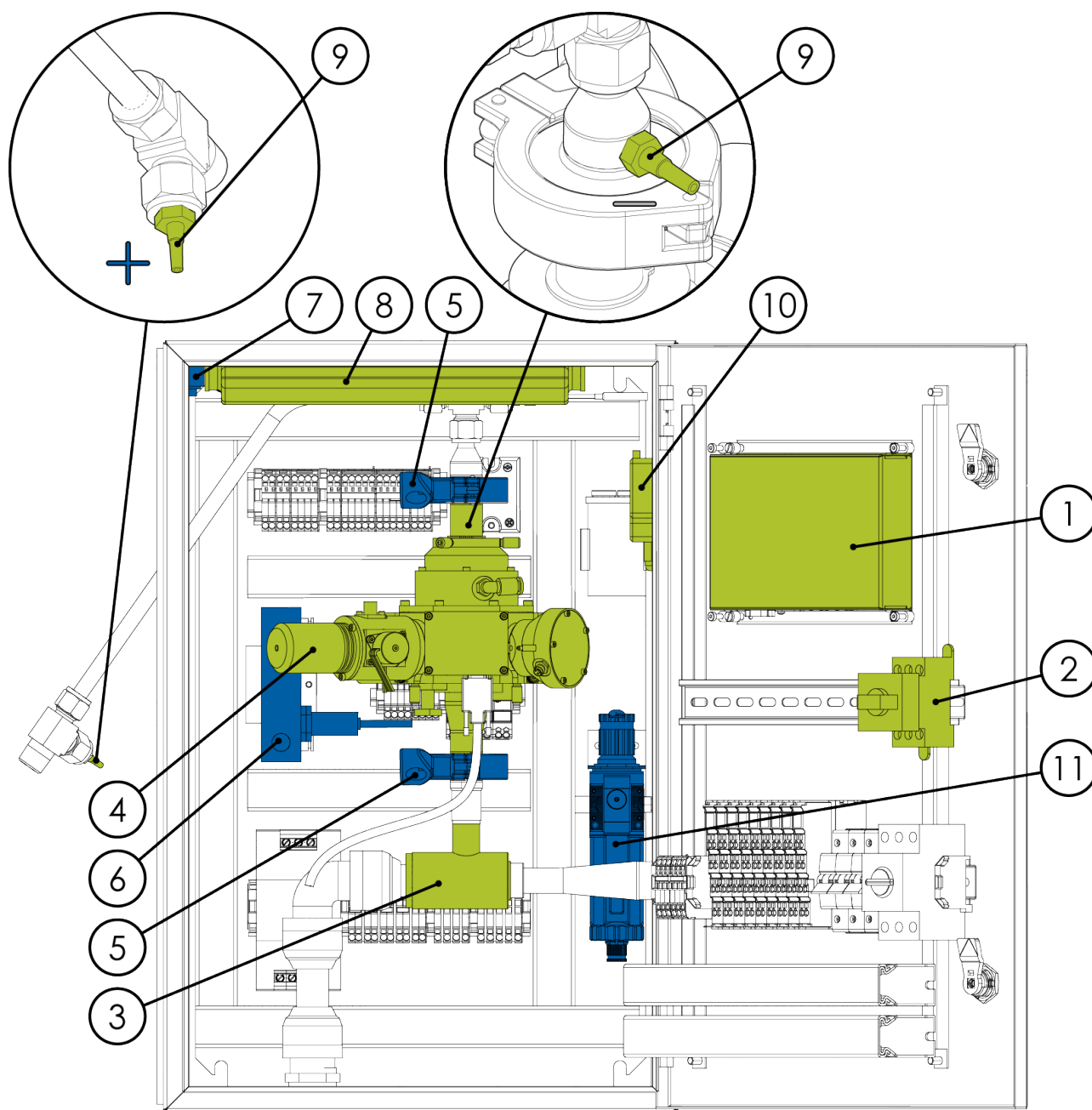

Figure 5: Major internal components of EXO dust monitor, right cabinet

① Integrated panel PC	⑦ Cabinet light switch
② Main power switch	⑧ Cabinet light
③ Ejector chamber	⑨ Differential pressure measurement point
④ Optical sensor module	⑩ Differential pressure transmitter
⑤ Quick-clamp connector	⑪ Regulator unit
⑥ Rotameter	

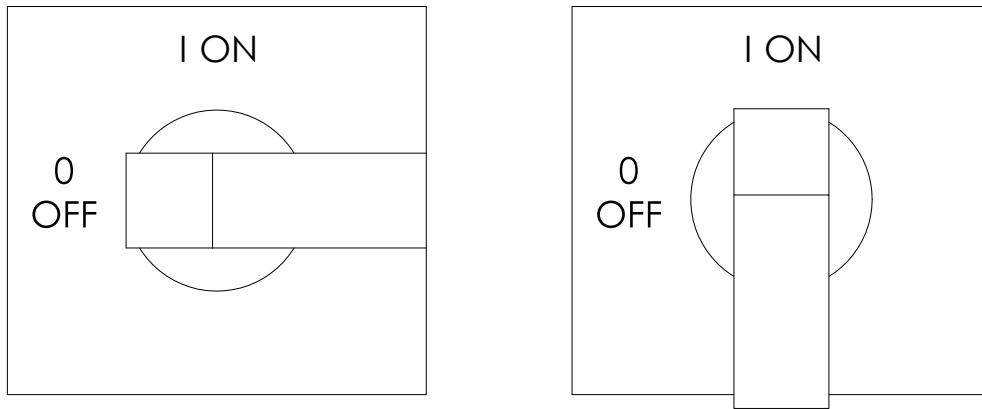

Figure 6: Main power switch in OFF and ON position

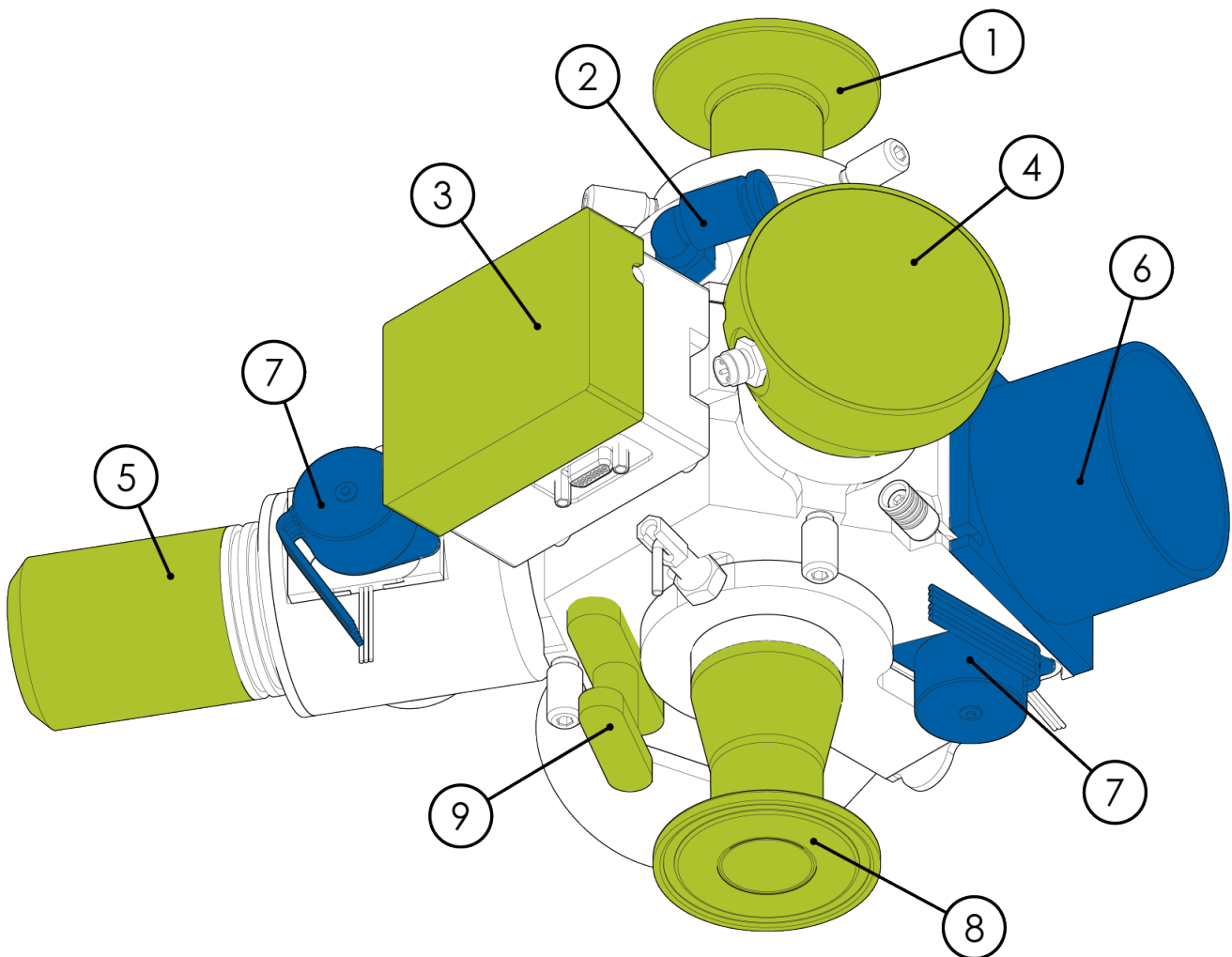

Figure 7: Optical XO sensor module

① Sample intake pipe	⑥ Mirror for reference light path
② Purge air inlet	⑦ Stepper motor
③ Connector housing	⑧ Sample outlet pipe
④ Scattered light detector	⑨ Holder for span check audit unit
⑤ LED light source	

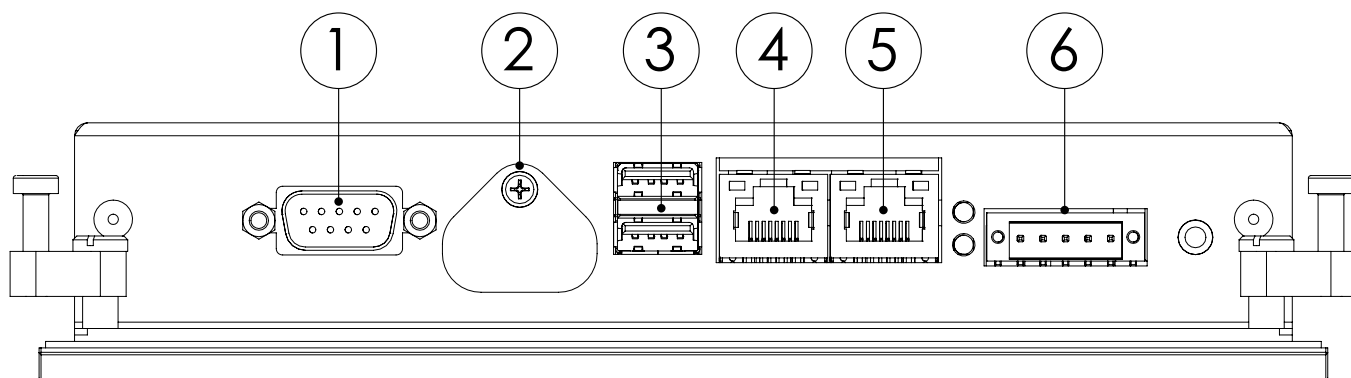

Figure 8: Connections of the integrated panel PC

① COM1 serial port (RS-232)	④ EtherCAT
② Battery and MicroSD cover plate	⑤ LAN1
③ 2× USB 2.0 port	⑥ Power

3.3 Identification

Identification label is located inside the device enclosure on the left door.



Figure 9: Identification label

① Device series	⑤ Serial number
② Device model	⑥ IP rating
③ Power supply specifications	⑦ Manufacturer details
④ Production date	⑧ CE marking

3.4 Scope of delivery

A standard delivery includes the following components:

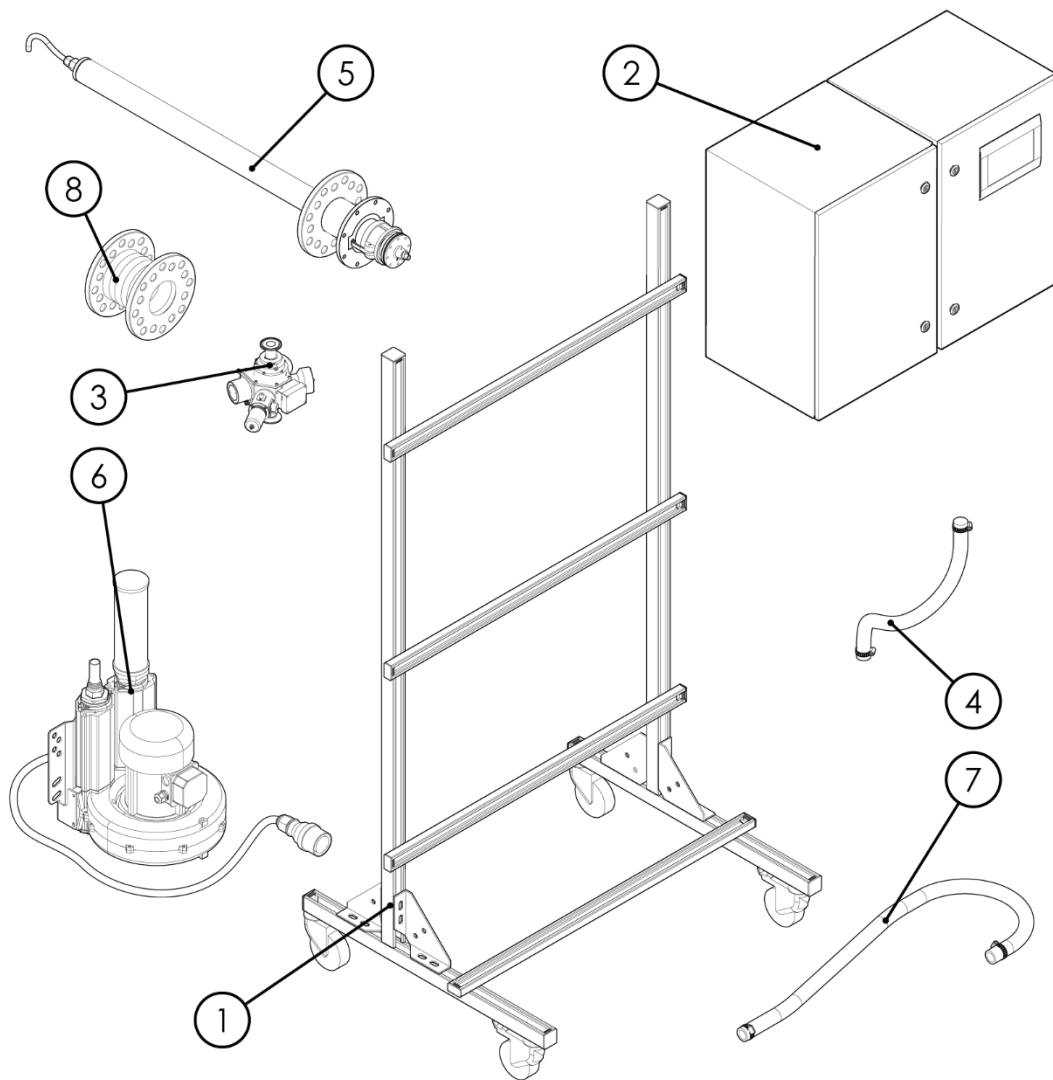

Figure 10: Components included in a standard delivery

① Mounting frame	⑤ Sampling probe with DN80/100 flange
② Enclosure containing sampling line and electronics	⑥ Sample air blower and power cord
③ Optical XO sensor module	⑦ Exhaust tube for return gas
④ Sample air tube for sample air blower	⑧ Rubber expansion joint with DN80/100 flanges

The enclosure consists of a two-part cabinet that is assembled at the factory. The piping and electronics for sampling and device control are installed upon delivery, and most of the electrical connections are already made. The installation technician installs the probe and sensor module to the enclosure, mounts the device on the frame, and connects the sample air blower and exhaust tube.

3.5 Features and accessories

3.5.1 Standard features

A standard delivery includes the following features:

Table 2: Overview of standard features of EXO dust monitor

Feature
IP54-rated powder coated steel enclosure
Integrated panel PC with touchscreen input
Dust concentrations displayed in mg/m ³
Analog and digital outputs for integration into existing control systems
Data logging onto a memory stick via USB connection for troubleshooting
Possibility to control the device with an external computer using Ethernet cable
Automatic cleaning and self-diagnostics functions during normal operation
Manual span check with span check audit unit

3.5.2 Optional features and accessories

The device can be customized to meet the specific requirements for various applications and process conditions.

Probe material

Standard sampling probe is made of stainless steel (316L). In case the device is used in processes that contain corrosive substances such as acids, the device can be delivered with a sampling probe made of Hastelloy C276.

Probe length

Standard probe length is approximately 1 meter (3.28 ft), but longer or shorter probe can be delivered according to client specifications.

Recommended probe lengths are as follows:

- For measurement in stacks with diameters between 1 to 4 meters, a probe length of one third ($\frac{1}{3}$) to two thirds ($\frac{2}{3}$) of the duct diameter is recommended.
- For measurement in stacks with diameters over 4 meters, a probe length of 1.5 or 2 meters is usually enough.

Depending on the stack diameter, it is enough for the probe to extend one to two meters inside the stack to extract a representative sample of the flue gas. Particle flow velocity does not affect the measurement results of the device.

Process connection

Standard probe is equipped with a DN80/100 multi-purpose flange and an expansion joint with DN80/100 flanges for connecting the device to the stack. Different flange sizes and configurations are available according to client specifications.

Purge air blower

To keep the optics of the XO sensor module clean, a stream of clean purge air must be directed through the module. Standard device uses pressurized process air from the plant that is directed to the sensor module through an entry located on the bottom of the enclosure. Inside the enclosure, the purge air hose is connected to an air filter regulator unit that directs the airflow to the sensor module through a rotameter. The rotameter is equipped with a proximity sensor that monitors the air flow.

For situations where it is not possible to use process air from the plant, the device can be delivered with an internal blower that supplies the sensor module with a steady stream of purge air. When ordered with the internal purge air blower, the device enclosure has a dust filter on one of its sides. When equipped with the internal purge air blower, the device has no regulator unit.



If you must change the method of supplying purge air after installation, contact the manufacturer or an authorized distributor.

Installation angle

When used in wet processes or condensing conditions, it is recommended to install the device so that there is a 3° downward tilt on the sampling probe. This ensures that condensed liquids do not enter the device enclosure when the sampling is not running.

The tilt is achieved by using slightly longer mounting brackets on the bottom side of the enclosure when securing it to the mounting frame.



When installing the device with the 3° downward tilt, the counter flange must have a corresponding upward tilt.

Remote access device



Remote access device is a different feature than the Remote Display Control software (CERHOST). Using CERHOST is a standard feature to control the device locally, while using the remote access device is an optional service offered by the manufacturer.

The device can be equipped with a remote access device that enables the manufacturer to access and monitor the device remotely through mobile network and VPN. This is an additional service that is done only on the request of the client.

The remote access device is configured at the factory, and it is inaccessible to the end-user. If you want to set up remote monitoring, contact the manufacturer or an authorized distributor.

Outdoor use in various weather conditions

The device is designed for use in both indoor and outdoor applications. The device can be fitted with optional accessories to accommodate various weather conditions in outdoor installations.

- If the device is exposed to rain and direct sunlight, it is recommended to equip the mounting frame with an optional weather protection roof.
- If the device is used in freezing temperatures below 0 °C (32 °F), it is recommended to equip the device with a winter package that consists of a protective snow and ice cover, fan heater and thermostat.

If you want to use the device in outdoor applications in rough conditions, for example in areas with very high outdoor temperatures, contact the manufacturer or an authorized distributor for more details.

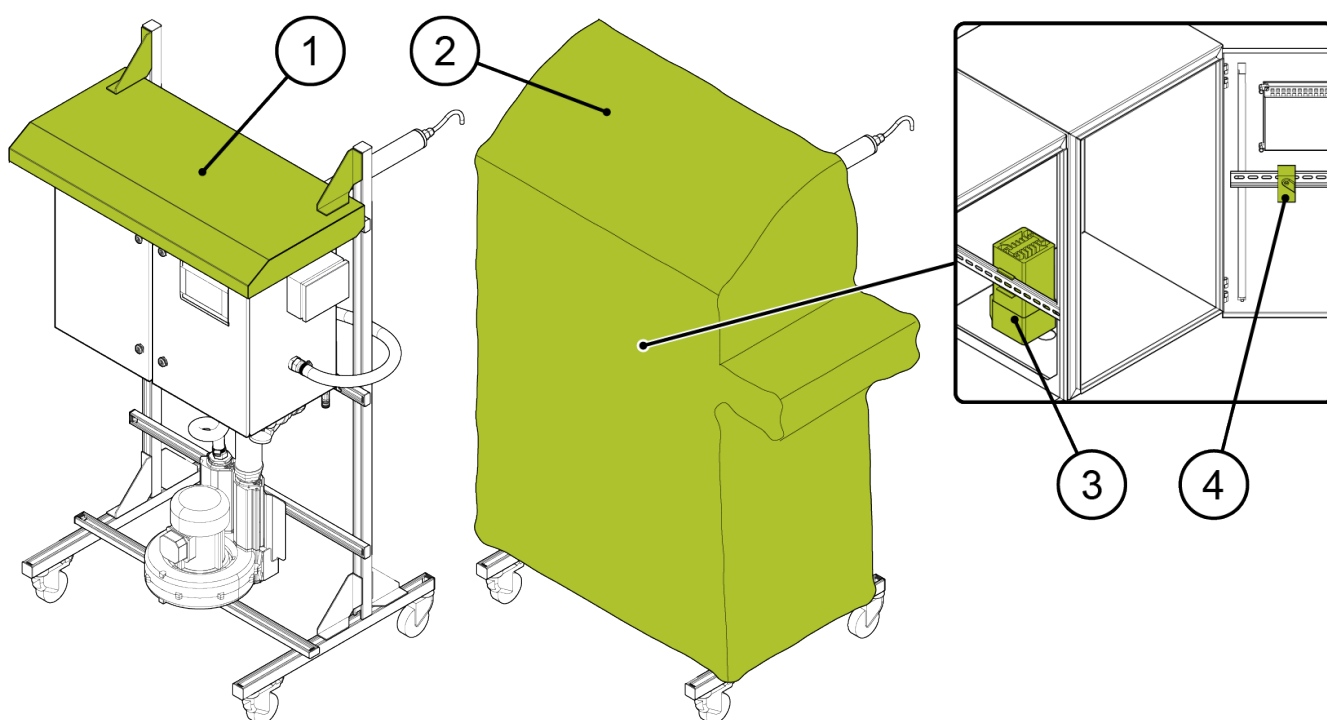

Figure 11: Optional weather protection accessories

① Weather protection roof	③ Fan heater
② Snow and ice cover	④ Thermostat

4 Functional description of sampling line

4.1 Operating principle

EXO dust monitoring system is based on optical forward scattering method, where light from an LED is directed through a particle stream moving through an optical sensor module. The light scatters when it reflects from the particles, and the scattered light is captured by a scattered light detector. The detector generates a signal based on the amount of scattered light it perceives. A logic module reads the signal and uses it to determine the particle concentration in the gas sample.

Using the optical forward scattering method to measure dust levels means that humidity, process gas flow velocity and electrically charged dust particles do not affect the measurement results.

4.1.1 Scattered Light Value

The measurement unit for the raw signal generated by the optical XO sensor module is called Scattered Light Value (SLV). The SLV output is converted to mA signal and mg/m³ value that the device uses to display the measurement results and communicate the dust level to the monitoring system.

The relation between the SLV and the display units is established during commissioning. The SLV output is calibrated to the process conditions against a reference measurement, for example the results of gravimetric analysis.

4.2 Functional diagram of sampling line

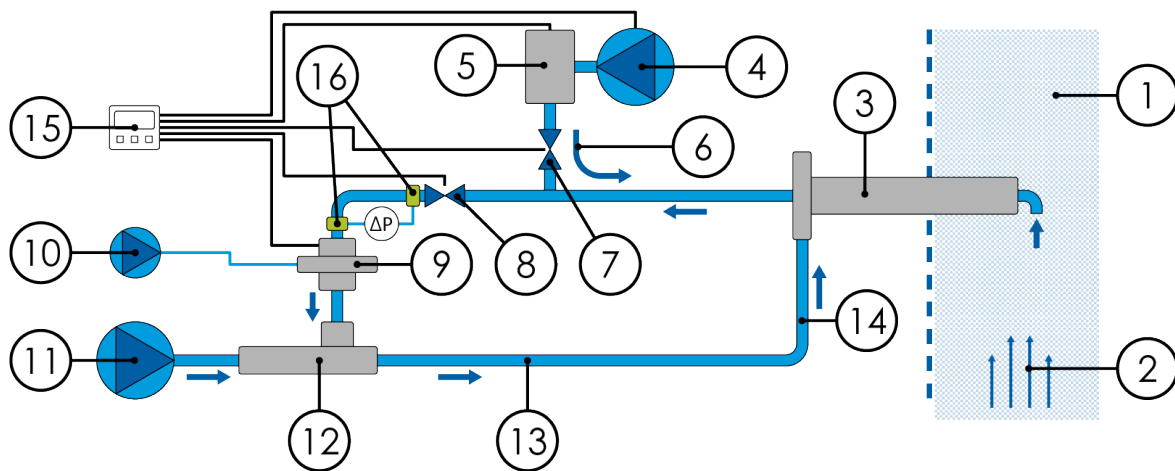

Figure 12: Functional diagram of the sampling line

① Stack	⑤ Pressure vessel	⑨ Optical XO sensor module	⑬ Exhaust tube for return gas
② Wet flue gas	⑥ Periodic blowback cleaning pulse	⑩ Purge air source	⑭ Sample return inlet
③ Heated sampling probe	⑦ Cleaning pulse valve	⑪ Sample air blower	⑮ Measurement control unit
④ Compressor	⑧ Flue gas valve	⑫ Ejector chamber	⑯ Sampling flow measurement

4.3 Measurement cycle

During a measurement cycle, the device continuously extracts a gas sample from the stack through a sampling probe that is connected to the stack with a flange. The probe is fitted with heating element that evaporates moisture from the gas sample. The device monitors the sample gas temperature at the sampling probe intake and outlet, between the probe and flue gas valve, and between the flue gas valve and the optical XO sensor module.

The heating element is typically kept between 185 ... 450 °C (365 ... 842 °F) depending on the process conditions and ambient temperature. The temperature of the gas sample is around 120 ... 140 °C (248 ... 284 °F) when it exits the probe. The sample cools down to approximately 110 ... 120 °C (230 ... 248 °F) before entering the optical XO sensor module. The temperature parameters are set during commissioning and optimized according to the process conditions and ambient temperature at the installation location.

During sampling and measurement, the flue gas valve is open and the cleaning pulse valve is closed, as shown in Figure 13.

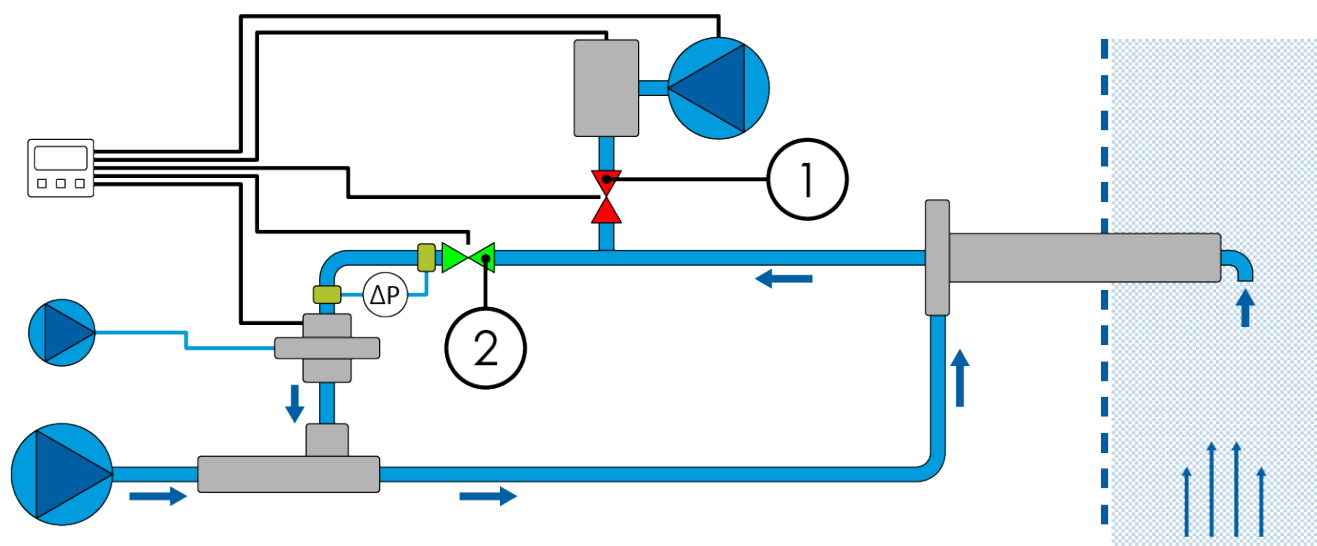

Figure 13: Position of valves during normal operation (green = open, red = closed)

① Cleaning pulse valve (closed)

② Flue gas valve (open)

Inside the sensor module, an LED shines a light through the measurement chamber that the sample passes through. A photodiode receiver in the scattered light detector captures some of the scattered light, and generates a signal based on the amount of scattered light. A logic module uses this information to determine the particle concentration in the sample, and the control unit displays the measurement results.

After passing through the sensor module, the sample enters an ejector chamber. The sample air blower is connected to the chamber, creating a suction effect that draws flue gas through the internal piping of the device, and ejects it back into the stack. The sample return inlet is fixed between the flanges that connect the probe to the enclosure and to the stack. However, it is also possible to install a separate return inlet on the side of the stack.

4.4 Cleaning pulse function

The device has a built-in cleaning pulse function that is designed to keep the internal piping of the device clean. During sampling, the dust and dirt from the gas samples can accumulate on the inner surface of the pipes. To clean the pipes, the device periodically shoots a pressurized air pulse through the sampling probe back into the stack.

During the cleaning pulse, the flue gas valve is closed to prevent pressurized air from entering the optical XO sensor module, and the compressor increases the pressure inside the pressure vessel up to 6 bar (87 psi). When the compressed air inside the vessel reaches the target pressure, the cleaning pulse valve is opened, and the compressed air is released into the piping. Figure 14 illustrates the position of valves during the pressurized cleaning pulse.

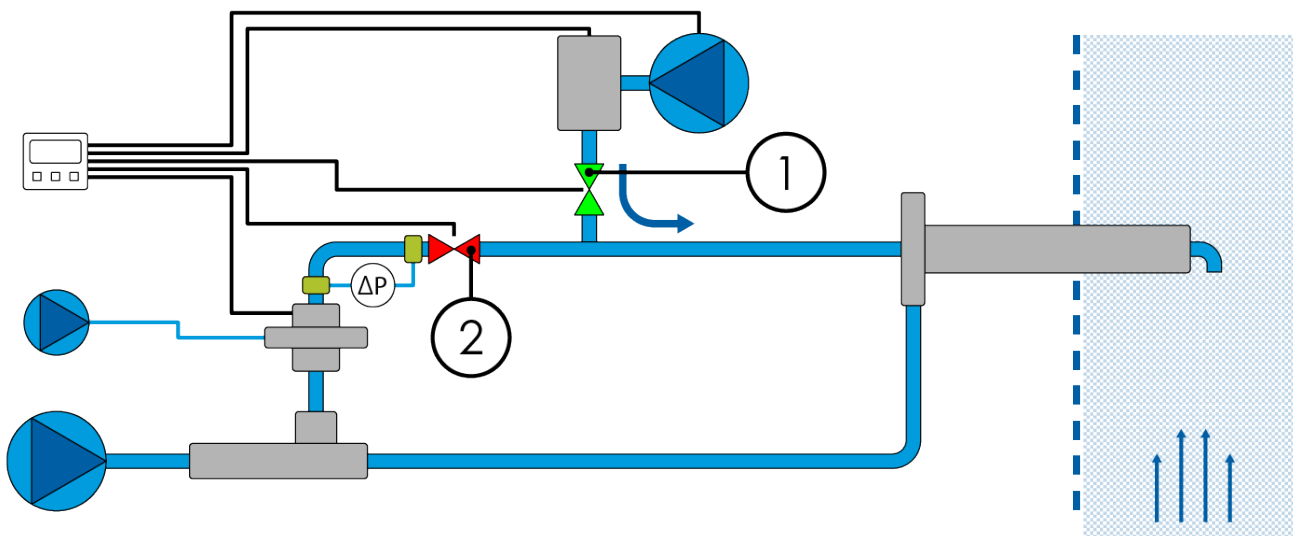

Figure 14: Position of valves during pressurized cleaning pulse (green = open, red = closed)

① Cleaning pulse valve (open)

② Flue gas valve (closed)

After the compressed air is released from the pressure vessel, the cleaning pulse valve closes, the flue gas valve opens, and the device returns to normal operation.

The device performs the cleaning cycle periodically, and you can adjust the cleaning interval in the device settings. Additionally, the device performs the cleaning cycle whenever the measurement sampling is started. This means that you can initiate the pressurized cleaning pulse manually by shutting and restarting the measurement operation.

4.5 Optical XO sensor module

4.5.1 Structure and components

The optical XO sensor module consists of four separate module chambers that house the light source, two stepper motors, a scattered light detector and all the optics required to guide and reflect the light to the correct location. The particle stream from the extracted gas sample is directed through the measurement chamber, located in the middle of the sensor module. Figure 15 and Figure 16 show the layout of the sensor module, identify its different parts and illustrate the basic operating principle.

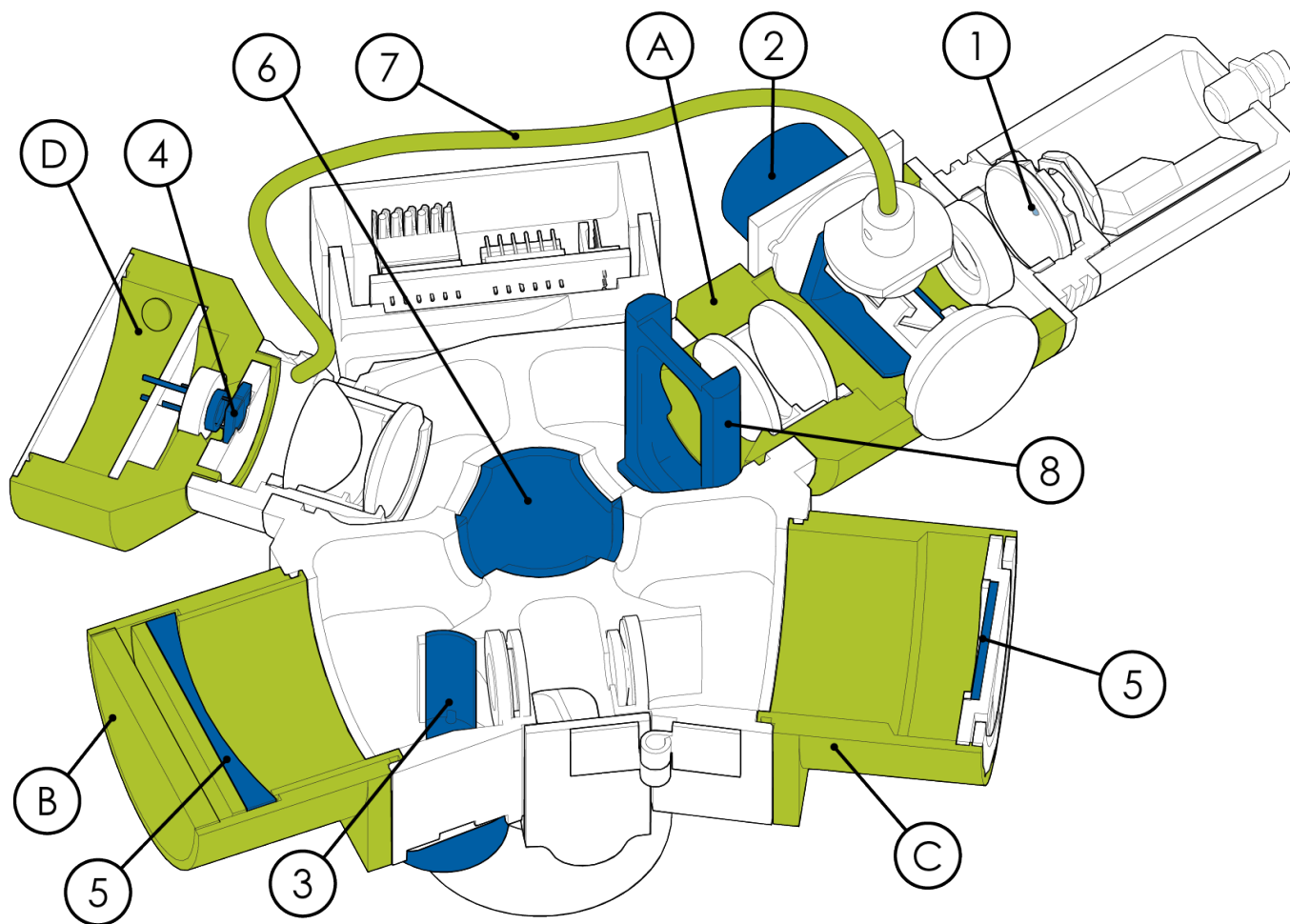

Figure 15: Components of the optical XO sensor module

A	Module chamber A	①	LED light source	⑤	Mirror
B	Module chamber B	②	Stepper motor A	⑥	Measurement chamber
C	Module chamber C	③	Stepper motor B	⑦	Optical fiber
D	Module chamber D	④	Scattered light detector	⑧	Holder for span check audit unit

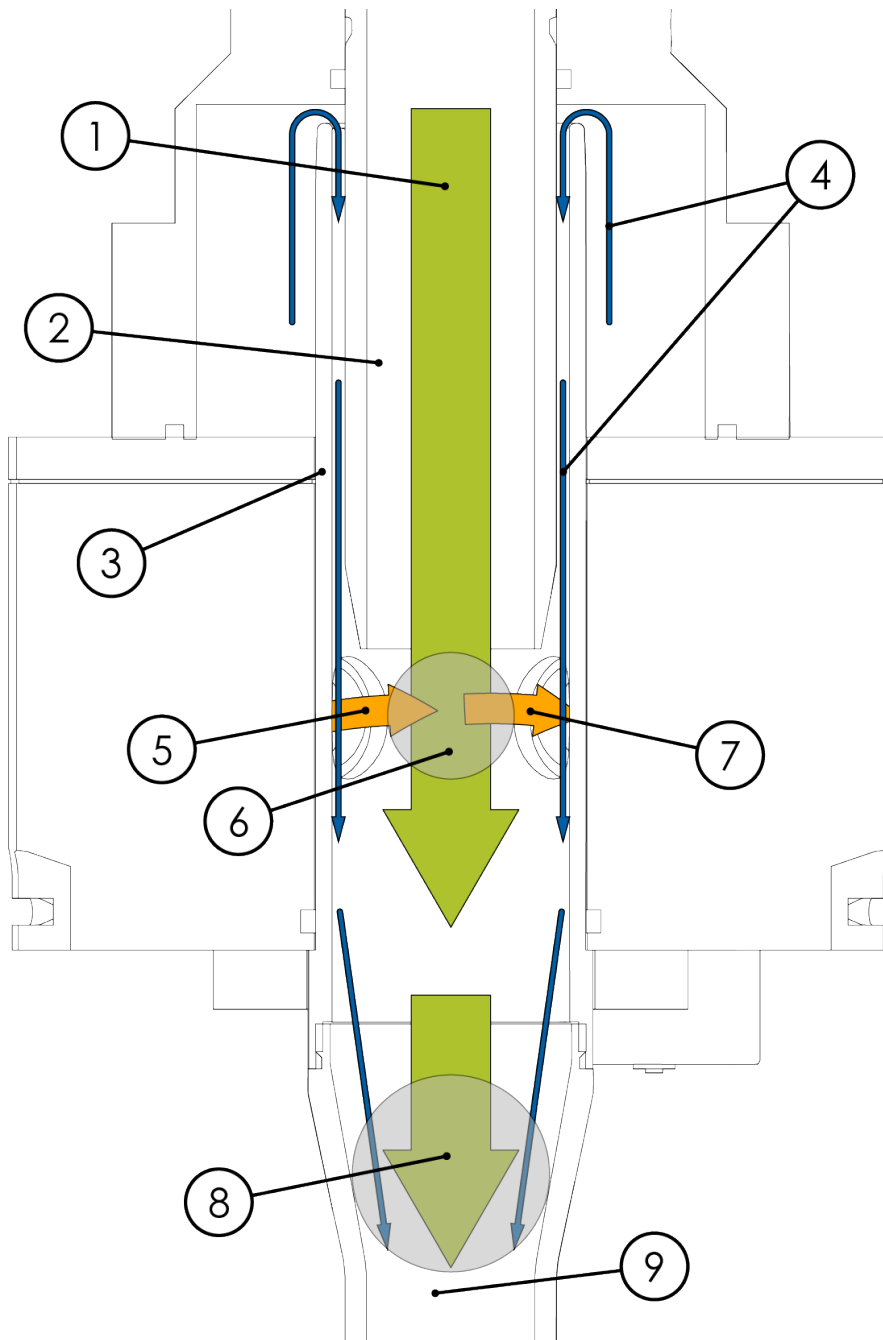

Figure 16: Operating principle of the optical XO sensor module

① Particle stream from the gas sample	⑥ Measurement region
② Inner pipe	⑦ Scattered light to the photodiode
③ Outer pipe	⑧ Particle and purge air mixing zone
④ Purge air stream	⑨ Suction created by the sample air blower
⑤ Light beam from the LED light source	

4.5.2 Normal operation

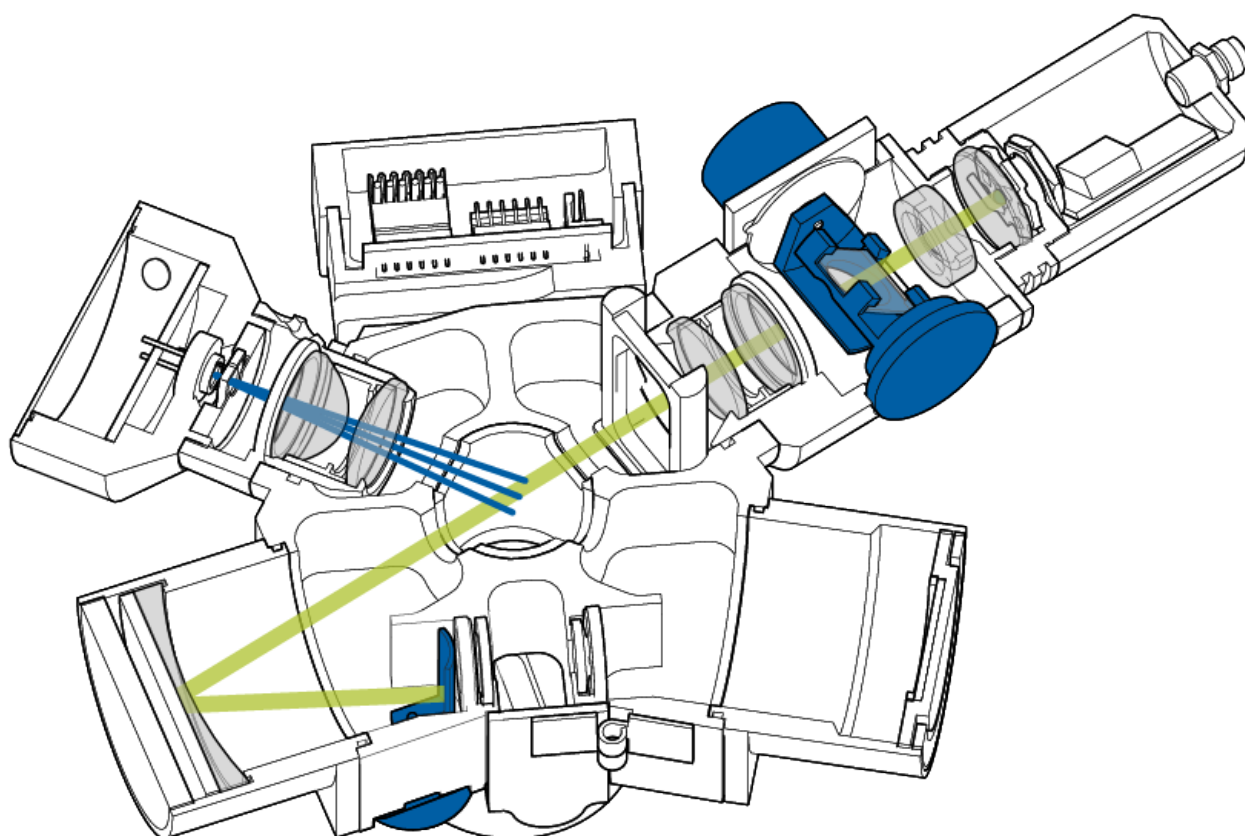

Figure 17: Path of the light during normal operation

In normal operation, stepper motor A is in open position, allowing the light to travel through the measurement chamber. Module chamber B is located opposite to the light source. It houses a mirror, which reflects the light towards module chamber C. However, in normal operation stepper motor B is in closed position, blocking the light from entering the next chamber. Figure 17 illustrates the path that the light travels in normal operation.

When the light travels through the measurement chamber, scattered light is reflected to chamber D that houses the scattered light detector, which has a photodiode receiver. The detector generates a signal based on the amount of scattered light it detects, and passes the signal to the measurement control unit. The signal strength is proportional to the particle concentration in the gas sample.

4.5.3 Signal comparison check

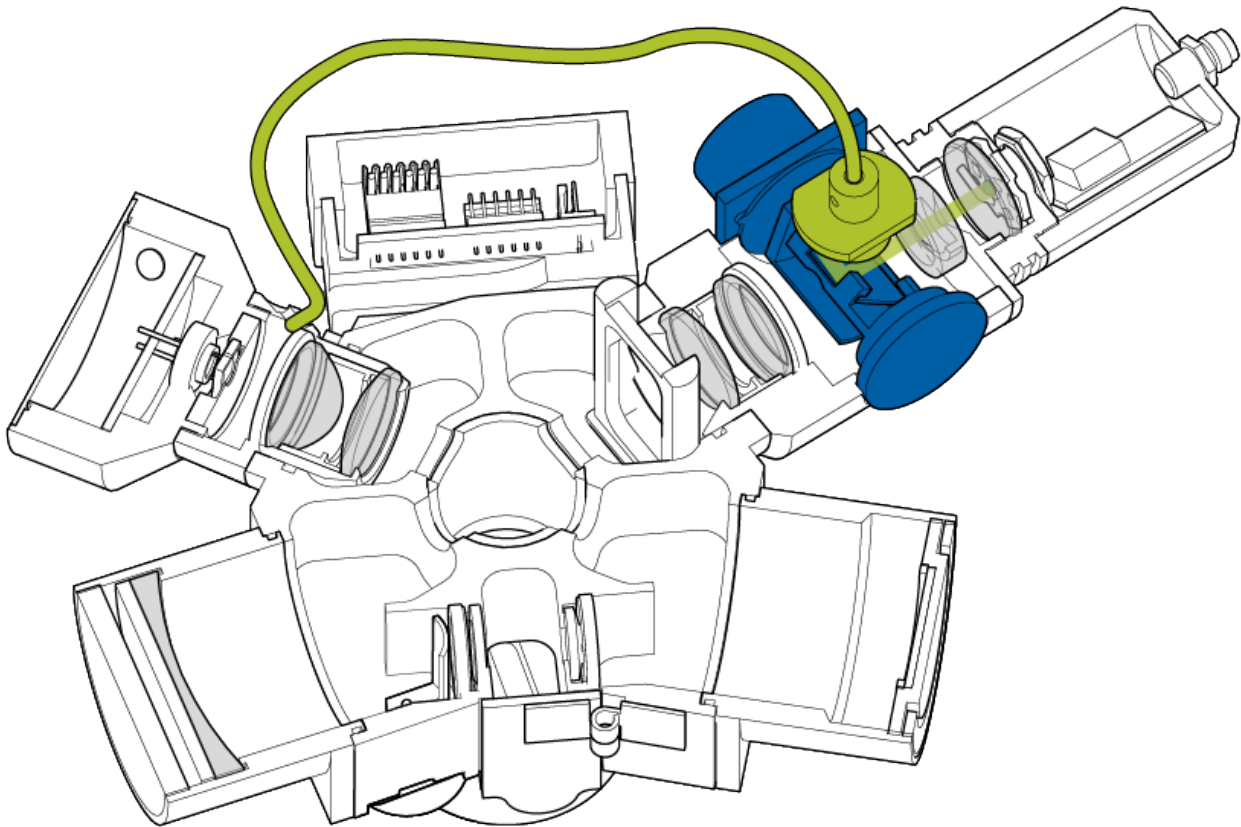

Figure 18: Path of the light during signal comparison check

The device performs a periodical signal comparison check to identify any changes in the measurement response that the ageing of the light source and photodiode receiver in the scattered light detector can cause. The comparison check also enables the device to adjust the light source and scattered light detector to compensate any possible influence that temperature changes can have on the measurement results.

During signal comparison check, stepper motor A rotates to closed position, blocking the light from entering the measurement chamber. Figure 18 illustrates the position of stepper motors and the path that the light travels during comparison check.

Instead of the light traveling through the measurement chamber and the scattered light detector picking up scattered light, the comparison signal is passed directly to the receiver diode through a beam splitter and an optical fiber. The scattered light detector generates a signal and passes it to the measurement control unit, where the measurement results are compared to a factory-set reference value.

If the results of the comparison check deviate from the reference value 30% or more, the device displays an error message. If the deviation is 60% or more, the device also disables the analog mA output.

See section **Signal comparison check** in chapter **Operation** for instructions on how to start the signal comparison check manually.

See section **Error messages** in chapter **Troubleshooting** for error messages and their description.

4.5.4 Reference check

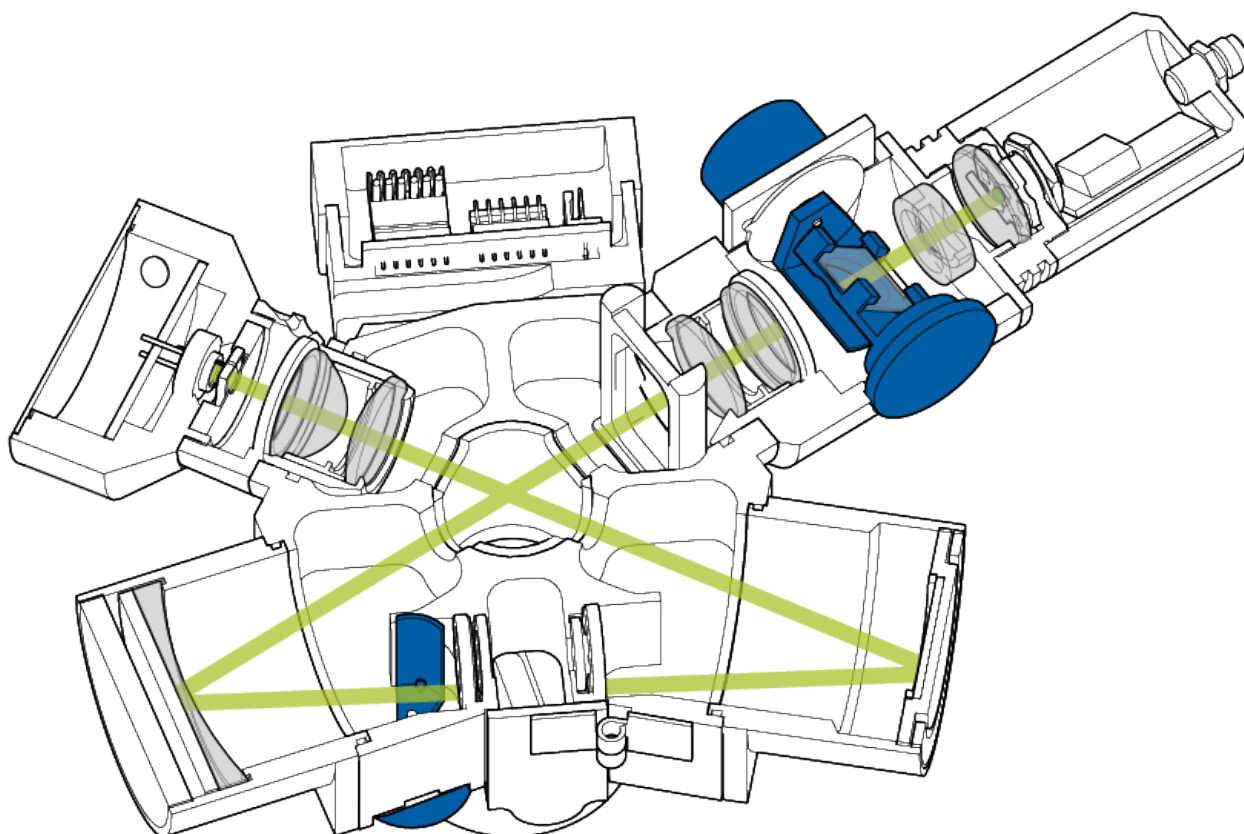

Figure 19: Path of the light during reference check

Dust accumulation on the internal mirrors, lenses and other surfaces of the sensor module can affect the measurement results. The device performs a periodical reference check to identify any contamination in the optics of the sensor module.

During reference check, both stepper motors are in open position, allowing the light to be reflected from the mirrors in module chambers B and C, and hit the scattered light detector directly. Flue gas valve is closed during reference check, so there is no particle stream in the measurement chamber. Figure 19 illustrates the path the light travels during reference check.

The scattered light detector generates a signal and passes it to the measurement control unit, where the measurement results are compared to a factory-set reference value. The device can compensate < 30% drift in the measurement response.

If the results of the reference check deviate from the reference value 30% or more, the device displays an error message. If the deviation is 60% or more, the device also disables the analog mA output. In such case, clean the optics and run the reference check again.

See section **Error messages** in chapter **Troubleshooting** for error messages and their description.

4.5.5 Manual span check



The expected measurement result for the manual span check is specific for each individual device. The manufacturer determines the expected value for each device and provides it to the end-user.

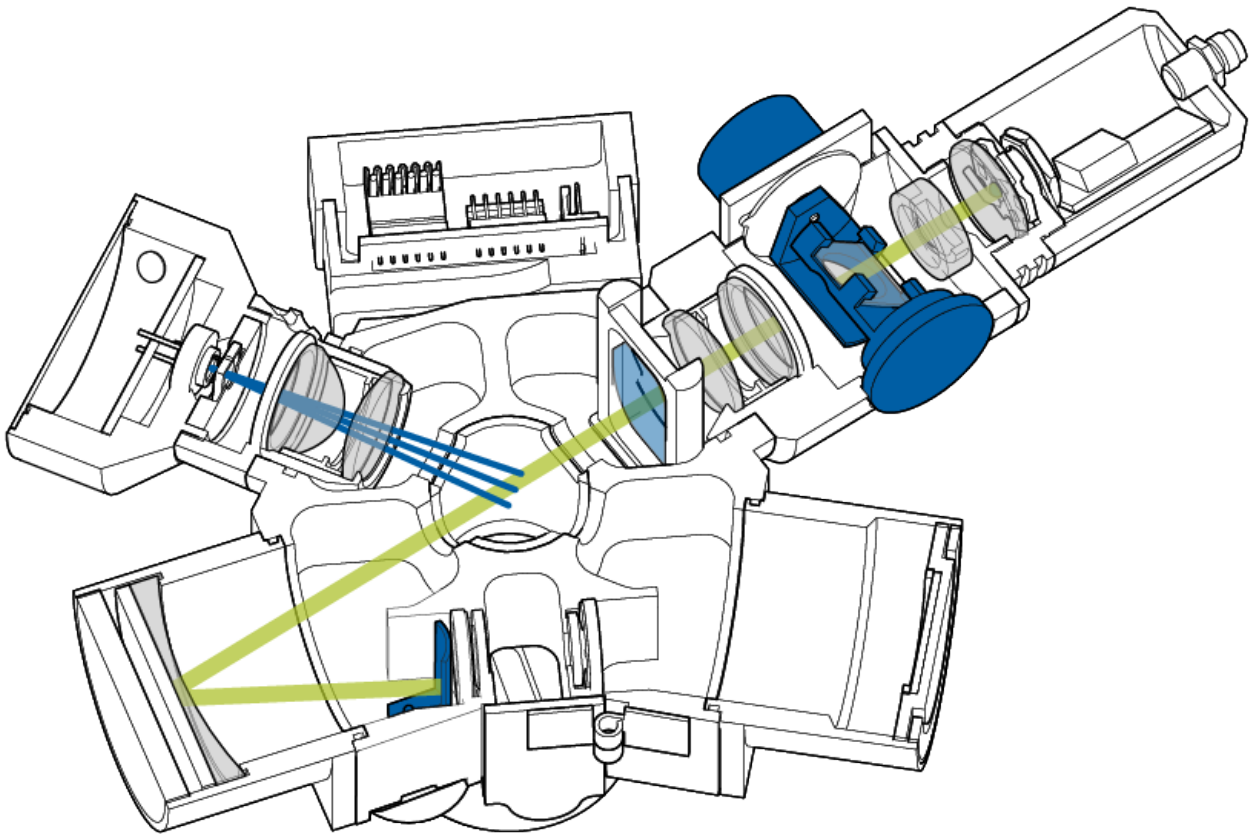

Figure 20: Span check audit unit (green block) inserted into the sensor module

To check the linearity of the measurement response of the optical XO sensor module, you must perform a manual span check. There must be no particle stream in the measurement chamber during span check. A span check audit unit is inserted into a slot on the bottom of the sensor module for the duration of the check. Stepper motor B is in closed position, so the light travels the same path as during normal operation. Figure 20 illustrates the location of the audit unit and the path the light travels during manual span check.

Manual span check can be performed during normal measurement if you are absolutely sure that there are no particles in the sample. In this case the sampling can be running during span check. If it is possible that there are particles in the sample, you must initiate the manual span check procedure on the user interface of the device. In this case you must close the flue gas valve and let the purge air clean the measurement chamber before performing the span check. This ensures that the measurement chamber is free of any particles.

See section **Manual span check** in chapter **Operation** for instructions on how to perform the manual span check.

4.6 Periodic self-diagnostics



Only Admin user can initiate the self-diagnostics function from the user interface. The self-diagnostics are performed automatically at a set interval during normal operation.

The device runs periodical self-diagnostics and cleaning functions to ensure that the sampling line and the optics inside the sensor module remain in good operating condition. During the procedure, the flue gas valve is closed and the device releases a cleaning pulse to ensure that the sampling line and the optical XO sensor module are free of dust for the self-diagnostics checks.

The self-diagnostics procedure consists of the following phases:

- Background noise check, where the device shuts the light source to identify any electronic interference on the measurement.
- Signal comparison check to monitor the condition of the LED light source.
- Reference check to identify any contamination in the optics of the sensor module.
- Automatic zero point check where the device measures the zero point of the signal by performing normal measurement with no particle stream in the measurement chamber.

After the self-diagnostics procedure is completed, the flue gas valve opens and the device resumes normal operation.

4.7 Flow measurement

4.7.1 Sampling flow measurement

The device uses isokinetic source sampling, where the velocity of the gas sample entering the sampling probe is kept equal to the flow velocity of the flue gas inside the stack.

An accredited testing facility performs the flow rate measurement to determine the flow rate inside the stack. The rotation speed of the sample air blower is then adjusted with a variable-frequency drive to create isokinetic flow between the stack and the sampling line. The flow velocity inside the sampling line is monitored using differential pressure measurement. The pressure measurement points are located on the sampling line before the gas enters the optical XO sensor module. If the pressure difference between the measuring points exceeds a set alarm limits, the device activates digital output 3.

4.7.2 Purge air flow measurement

The purge air line that directs cleaning air through the optical XO sensor module is equipped with a rotameter. A proximity sensor is connected to the rotameter. If the purge air flow is interrupted, the sensor activates digital output 8.

See section **Analog and digital outputs** in chapter **Electrical installation** for information about the digital outputs.

4.8 Potential influences on measurement results

4.8.1 Particle material

The device generates the measurement signal based on the amount of scattered light the particles moving through the measurement chamber reflect. This means that output signal strength can vary significantly from one particle material to another:

- The color of dust affects the amount of light it reflects. For example, black dust reflects less light than lightly colored dust.
- Size distribution, opacity and the shape of dust particles affects the way they reflect light.



The device measures and reacts properly to all types of dust materials. However, if the measured dust type or its size distribution changes significantly, the device must be calibrated to the new process conditions.

4.8.2 Particle size

Size and shape of the dust particles affect the way they reflect light. Typical particle size is within 0.5 ... 100 µm range.

4.8.3 Relative humidity

Variations in the relative humidity and condensation or droplets in the flue gas have no effect on the measurement results. The gas sample is heated before it enters the measurement chamber, so moisture and droplets are vaporized.

4.8.4 Ambient temperature

Ambient temperature only has a very minor effect on the output signal of devices using optical forward scattering method. The device can operate in $-40 \dots 50 \text{ }^{\circ}\text{C}$ ($-40 \dots 122 \text{ }^{\circ}\text{F}$) temperatures, and the device compensates any influence that the temperature can have on the measurement response.

4.8.5 Flow velocity

Flow velocity does not affect the output signal of device. The device uses isokinetic source sampling, where the velocity of the gas sample entering the measurement probe is kept equal to the flow velocity of the flue gas inside the stack. This is achieved by adjusting the rotation speed of the sample air blower with a variable-frequency drive.

5 Transport and storage

5.1 Unpacking and inspection

NOTICE

Improper handling during unpacking can damage the equipment.

When unpacking the device:

- If you use a knife or scissors to open the package, be careful not to damage the device or its parts.
- Handle the device and its components with care when taking them out of their packages.
- Do not drop the device or subject it to blows.

Inspect the device immediately after unpacking:

- Check that the device and all its standard and optional parts are included in the delivery.
- Inspect the device and its individual parts for any defects, or damage that may have occurred during delivery.

For instructions on how to return a damaged or defective device for repair or replacement, see section **Returns** in chapter **Maintenance and inspection**.

5.2 Storage

NOTICE

Improper storage can damage the equipment.

When storing the device:

- Select a dry, dust-free location with no major temperature or humidity fluctuations.
- Store the device and all its parts in their original packaging.
- Do not place any heavy objects on the device.
- Storage temperature must be within range $-25 \dots 65 \text{ }^{\circ}\text{C}$ ($-13 \dots 149 \text{ }^{\circ}\text{F}$).

Retain the original packaging in case the device is ever transported or returned.

5.3 Transport

WARNING!



Risk of injury

When transporting and lifting the device, there is a risk of the device falling or tipping. Standing near or under suspended loads poses a risk of bodily injury.

Use suitable transport and lifting equipment and provide enough support when transporting the device. Never stand near or under suspended loads.

When transporting the device:

- Use appropriate transport and lifting equipment with load capacity that exceeds the total weight of the device and its parts.
- If possible, transport the device and its parts in their original packaging to the installation location. If this is impractical, for example because of heavy packaging material, unpack the device as close to the installation location as possible.



The device packaging does not have designated lifting points. Load the device on the transport and lifting equipment evenly and provide enough support on each side.

6 Mechanical installation



Read chapter “Safety” carefully before installing the device.

6.1 Safety precautions

DANGER!



Poisonous and hot gas hazard

When installing or removing the device, poisonous and hot gas can be released from the duct.



Wear appropriate respiratory and eye protection gear when installing or removing the device. Follow all applicable local and plant-specific safety codes before proceeding.

WARNING!



Risk of burns due to hot components

When installing or removing equipment, the device or the installation surface can be hot.



Wear appropriate heat-resistant gloves and follow all applicable local and plant-specific safety codes before proceeding.

WARNING!



Risk of injury

The device and its parts are heavy. When moving and installing the device there is a risk of being crushed under falling equipment.



Do not attempt to move or install the device alone. Wear a hard hat and other appropriate protective equipment when installing the device.

6.2 Installation location



Any information given in this user manual regarding the installation location or suitability for a specific application does not replace careful functionality checks and necessary approvals from an industry specialist.

6.2.1 Ambient environment

NOTICE

If there are any structures that radiate heat near the device, you must insulate the heat source. Very high temperatures will damage the device.

To minimize the effect that the environment has on the measurement results, install the device in a suitable location. Table 3 shows the suitable ambient conditions for the device.

Table 3: Ambient conditions of the installation location

Ambient temperature:	-40 ... 50 °C (-40 ... 122 °F)
Relative humidity:	Max. 95 % RH

6.2.2 Location

An optimal location for installation is in a section of pipe or duct where the dust particles are evenly distributed in the airflow, and the flow is as laminar as possible. This ensures that the sampling probe comes into contact with an amount of particles that represents the actual dust concentration inside the stack.

6.2.3 Orientation

The device must be installed perpendicular to the airflow, so that dust particles pass the sampling probe at a 90° angle. The nozzle of the sampling probe can be rotated in any direction, so installation on both vertical and horizontal stacks and pipelines is possible.

6.2.4 Angle

It is recommended to install the device with a 3° downward tilt on the sampling probe. This ensures that condensed liquids do not enter the device enclosure when the sampling is not running.

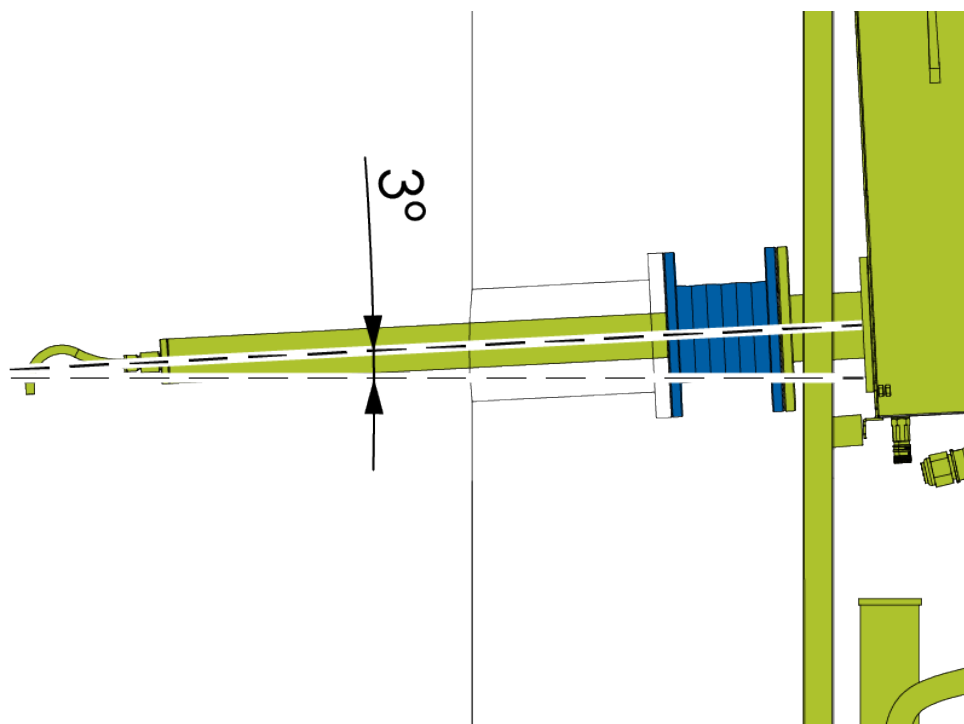

Figure 21: Installation with 3° downward tilt

The tilt is achieved by using slightly longer mounting brackets on the bottom side of the enclosure when securing it to the mounting frame.



When installing the device with the 3° downward tilt, the counter flange must have a corresponding upward tilt.

6.2.5 Probe length

Recommended probe lengths are as follows:

- For measurement in stacks with diameters between 1 to 4 meters, a probe length of one third ($\frac{1}{3}$) to two thirds ($\frac{2}{3}$) of the duct diameter is recommended.
- For measurement in stacks with diameters over 4 meters, a probe length of 1.5 or 2 meters is usually enough.

Particle flow velocity does not affect the measurement results of the device. Depending on the stack diameter, it is enough for the probe to extend one to two meters inside the stack to extract a representative sample of the flue gas.

6.2.6 Duct pressure

If possible, install the device in a location where the pressure inside the stack is lower than the surrounding environment. This prevents the process gases from being released or minimizes the amount of gas that is released from the stack during installation.

If the duct pressure is higher than the surrounding environment, there is a risk that process gases are released from the stack.

6.3 Preconditions for installation

Before installing the device, make sure that the following preconditions are fulfilled:

- You have made sure that all listed parts and components are included in the delivery, and you have inspected them for any damage or defects. A list of ordered components is included in the shipping documents.
- You have read the user manual and all the included safety instructions.
 - General safety information is outlined in chapter **Safety**.
 - Mechanical installation must be done according to instructions in chapter **Mechanical installation**.
 - Electrical connections must be made according to instructions in chapter **Electrical installation**.
- The device and all its components are transported to the installation site.
- The power supply is in place and fulfills all the requirements on the identification label of the device.
- You have all the necessary tools to complete the installation. A list of tools is included before each step in the installation process.
- All the cabling and connections to external systems (mA, digital I/O, Ethernet) are in place.
- Clean process air is available for purge air connection.
- The installation location has a compatible counter flange installed on the stack.

6.4 Installation

6.4.1 Mounting enclosure to mounting frame

WARNING!



Risk of injury

The mounting frame and device enclosure are heavy. When installing the device on the mounting frame, there is a risk of being pinned under the falling enclosure.



Do not install the device on the mounting frame alone. At least three persons are required for mounting the device enclosure onto the frame. Wear a hard hat and other appropriate protective equipment when installing the device.

The device enclosure is equipped with a total of eight mounting brackets (Figure 22). The mounting frame consists of profile rails that are equipped with bolts on sliding nuts. The enclosure is mounted on the frame by securing the mounting brackets on the bolts using washers and hex nuts.

The bolts, washers, and hex nuts required for mounting are already in place on the frame upon delivery (Figure 23). Two washers are attached to each bolt. One washer is larger than the other. Additionally, there is a hex nut attached to the bolt. The frame must be in an upright position when the device enclosure is mounted on it.

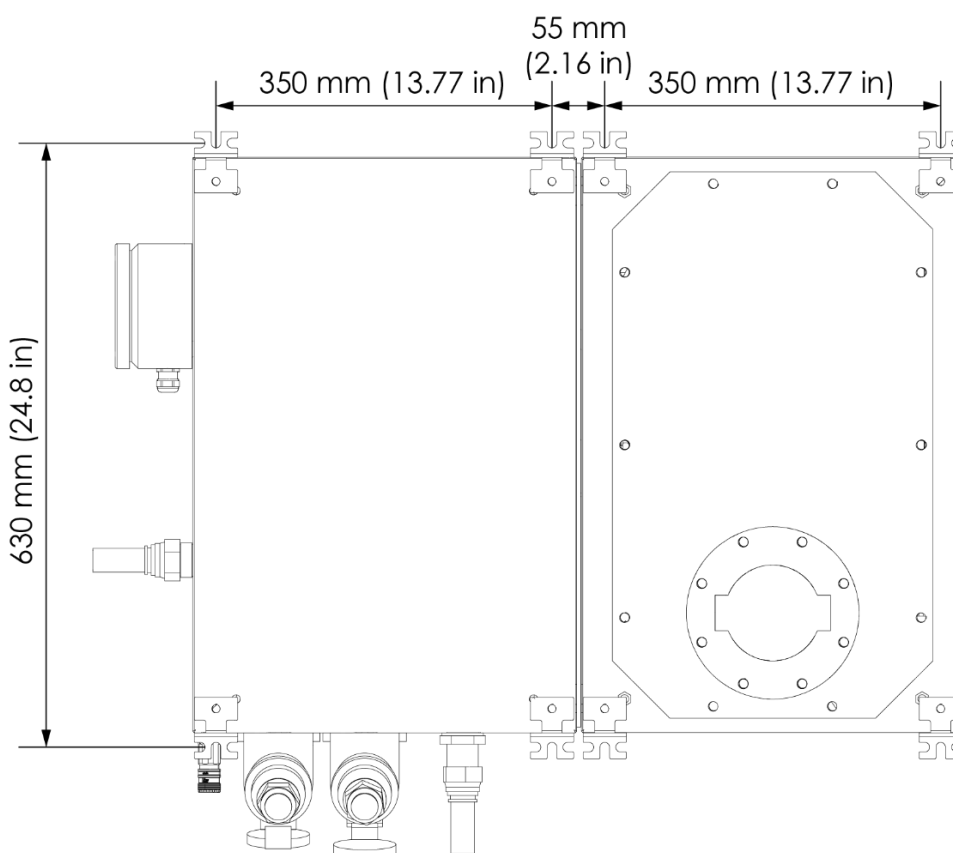

Figure 22: Distance between the mounting brackets on the device enclosure

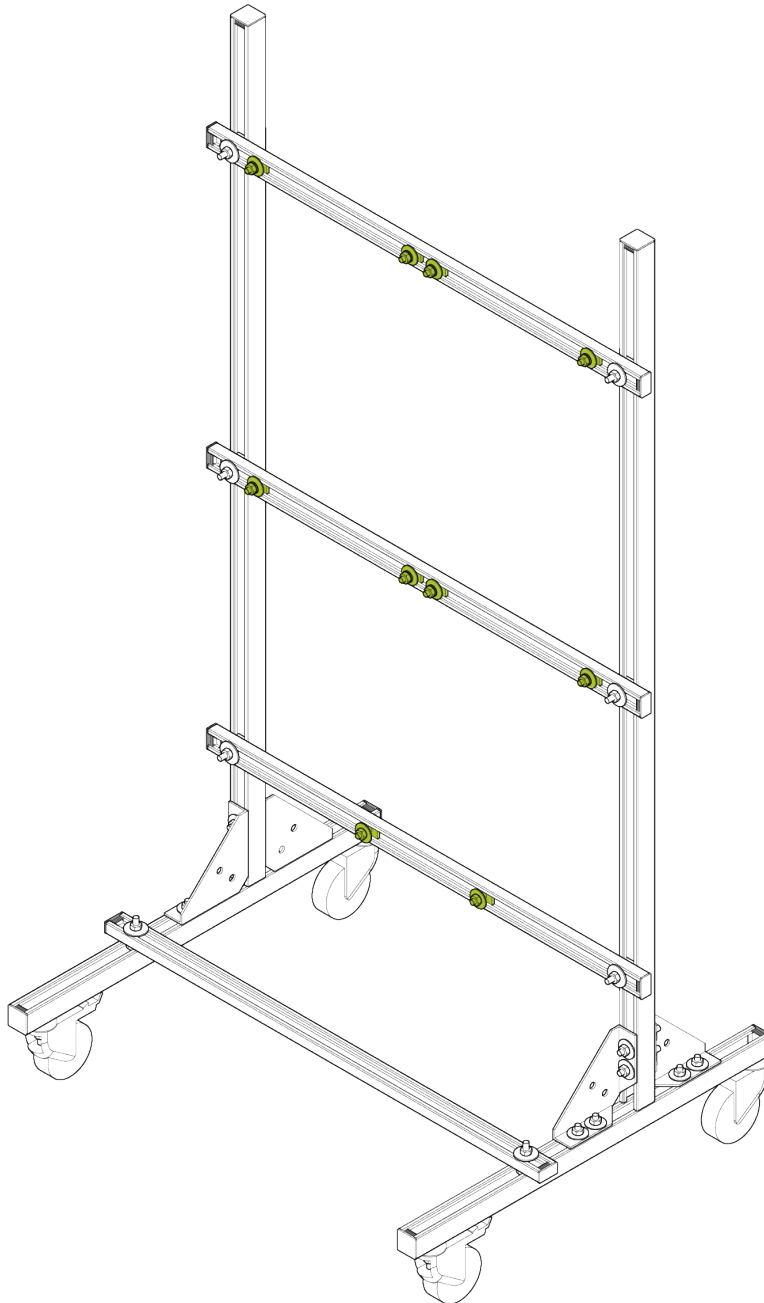

Figure 23: Mounting hardware on the mounting frame

To fit the dust monitor enclosure onto the mounting frame, you need:

- Wrench (17 mm [0.669 in])

To fit the dust monitor onto the mounting frame:

1. Remove a hex nut and small washer from each bolt. Leave the large washers in place.
2. To adjust the position of the bolts before fitting the enclosure onto the frame, simply slide the bolts along the profile.
3. Have two persons lift the enclosure onto the frame. They must support the enclosure and prevent it from falling or tipping when you secure the enclosure to the frame.
4. Secure the enclosure onto the mounting frame:

- a. Secure the top side of the enclosure to the mounting frame by tightening a hex nut on each bolt. Place a small washer on the bolt before tightening the hex nut.

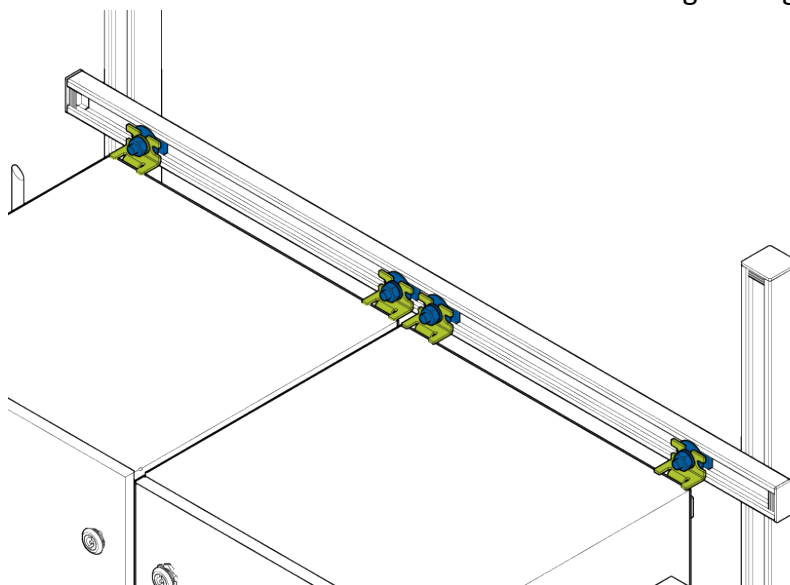

- b. Secure the bottom side of the enclosure to the mounting frame by tightening a hex nut on each bolt. Place a small washer on the bolt before tightening the hex nut.

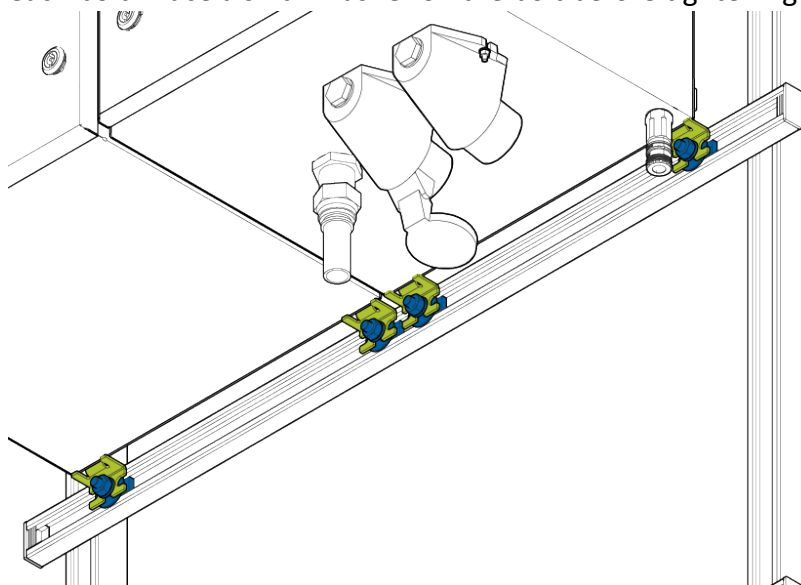

5. After securing the enclosure onto the mounting rack, inspect each bolt and hex nut, and make sure they are properly tightened.

6.4.2 Assembling process connection flange

In a standard delivery, the process connection flange on the backside of the device enclosure is already attached to the enclosure. Sometimes it must be disassembled for delivery and reassembled on-site. In this case, all bolts, washers and hex nuts required are included in the delivery.

To assemble the process connection flange, you need:

- Wrench (13 mm [0.512 in])

To assemble the process connection flange:

1. Place the flange gasket on the opening on the backside of the device enclosure.

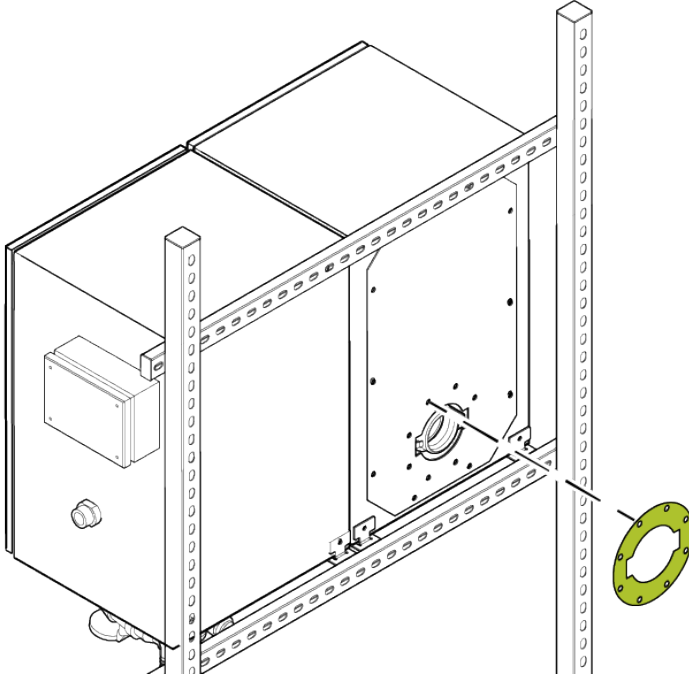

2. Insert the process connection flange through the opening. Make sure that the sample return inlet is pointing towards the ejector chamber air outlet.

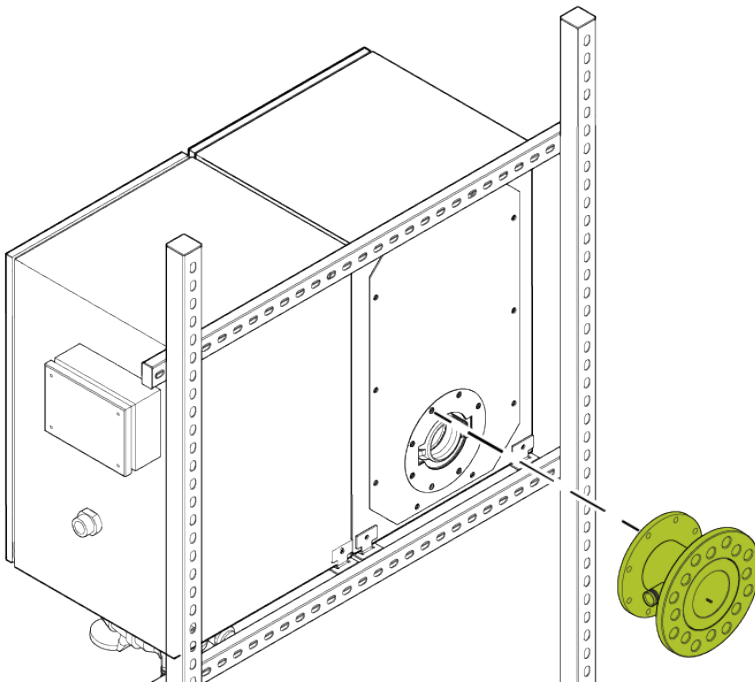

3. Secure the process connection flange in place using bolts and hex nuts.

- Insert a bolt through each bolt hole from the inside of the enclosure. Place a spring washer under each bolt head.
- Secure hex nuts on the bolts. Place a flat washer under each hex nut.
- Tighten the bolts and hex nuts in a way that applies compression to the flange uniformly, starting with bolts on the opposite sides of the flange joint.
- Select an appropriate tightening torque based on the bolts and hex nuts you are using.

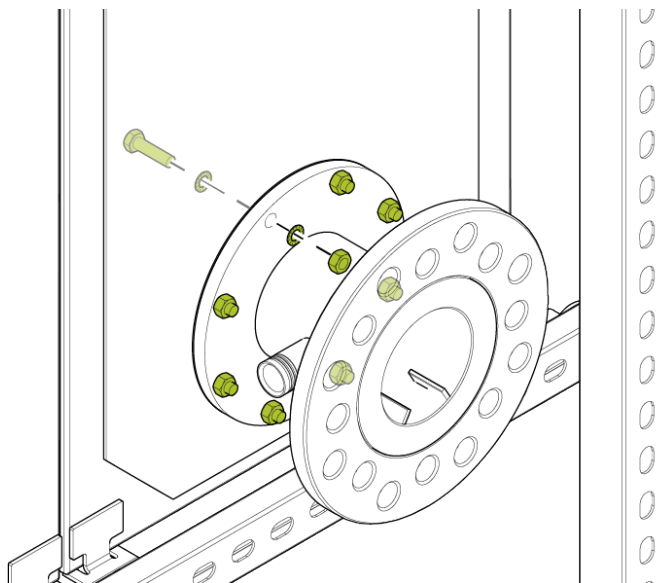

6.4.3 Connecting sampling probe to enclosure



These instructions are written with the assumption that the dust monitor is not yet connected to the stack. However, you can connect the dust monitor to the stack before connecting the sampling probe to the enclosure, for example if the installation platform does not have much room.

To connect the sampling probe to the device enclosure, you need:

- Wrench (22 mm [0.866 in])

To connect the sampling probe to the device enclosure:

1. Insert the sampling probe through the process connection flange from the inside of the enclosure.

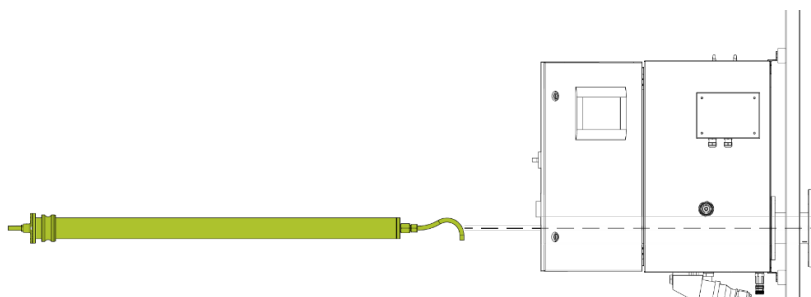



Make sure that the nozzle faces towards the incoming flue gas stream.

2. Engage the locking mechanism to secure the probe in place.

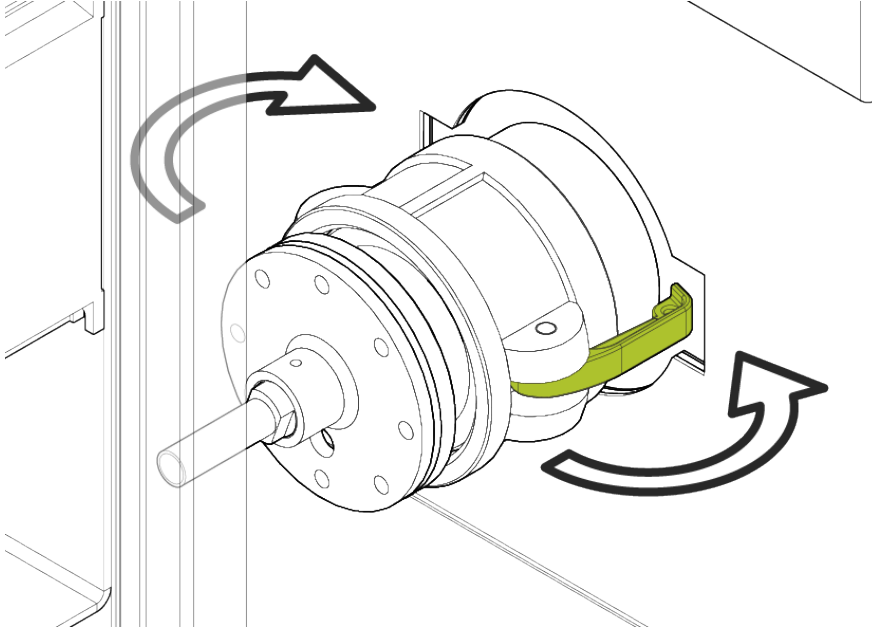

3. Connect the internal piping to the pressure vessel and the end of the sampling probe.

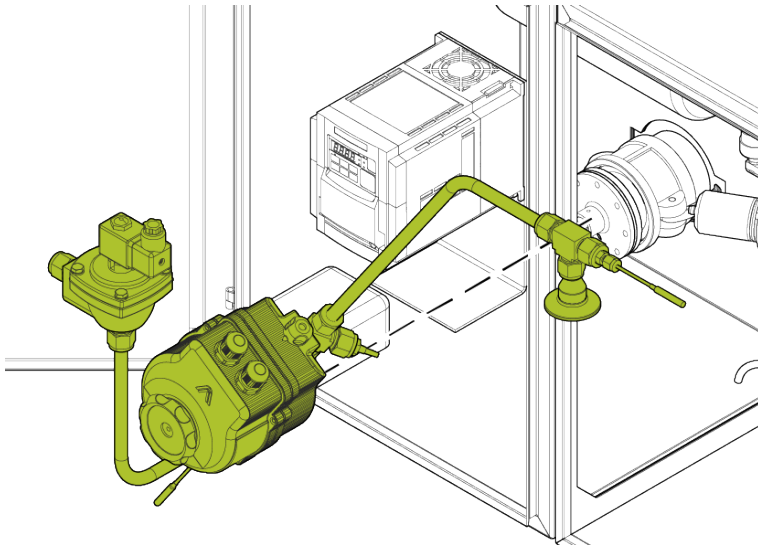

4. Secure the pipes together by fastening the hex nuts using a wrench.

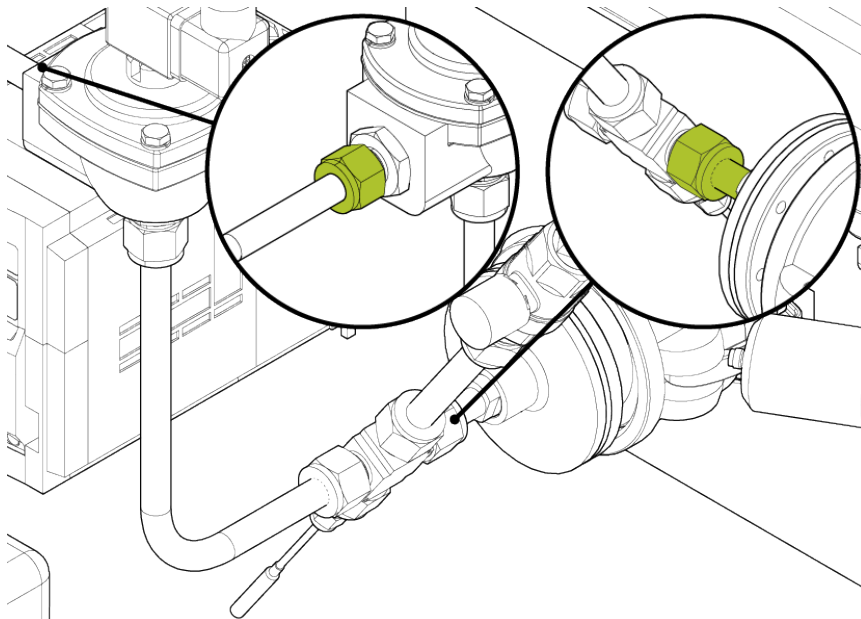

5. Connect the cables for the heater and thermocouples.

For instructions on making electrical connections for the heater and thermocouples, see section **Connections on sampling probe** in chapter **Electrical installation**.

6.4.4 Installing optical XO sensor module

NOTICE

The optical XO sensor module contains fragile optical components. Always handle the sensor module with care. Do not drop it or subject it to blows.

The sensor module connects to the sampling line through the sample intake pipe on the top side, and to the ejector chamber through the sample outlet pipe on the bottom side. During installation, make sure that the signal cable port on the connector housing is facing down. See Figure 24 for an illustration of the correct orientation.

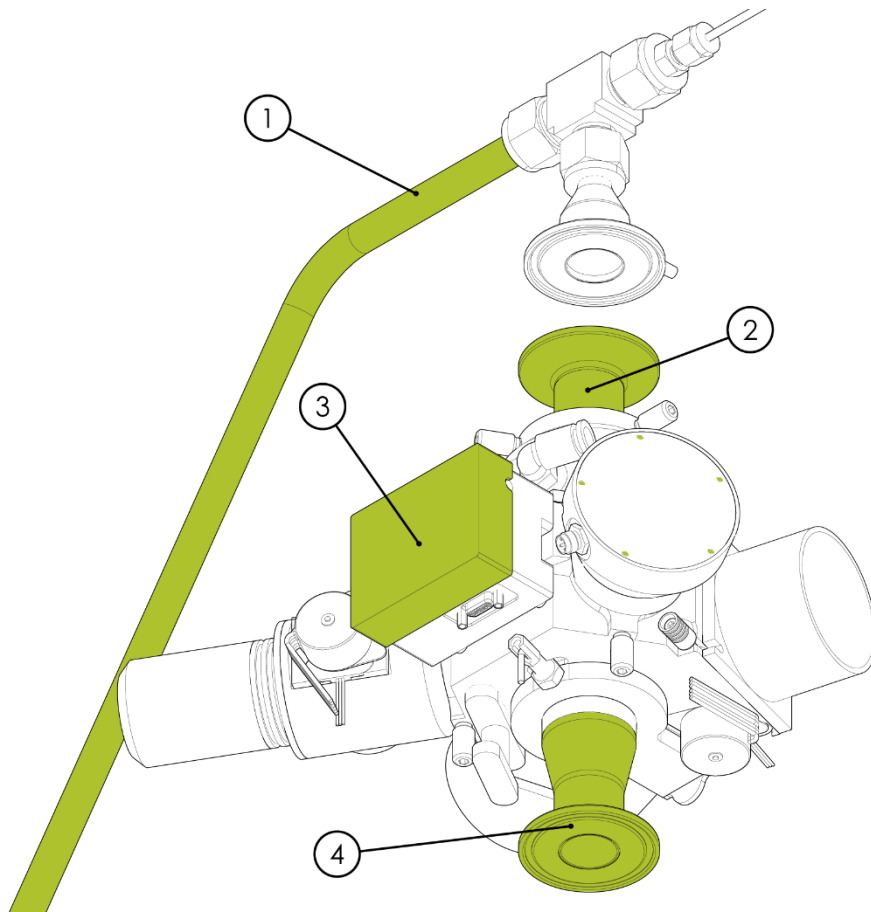
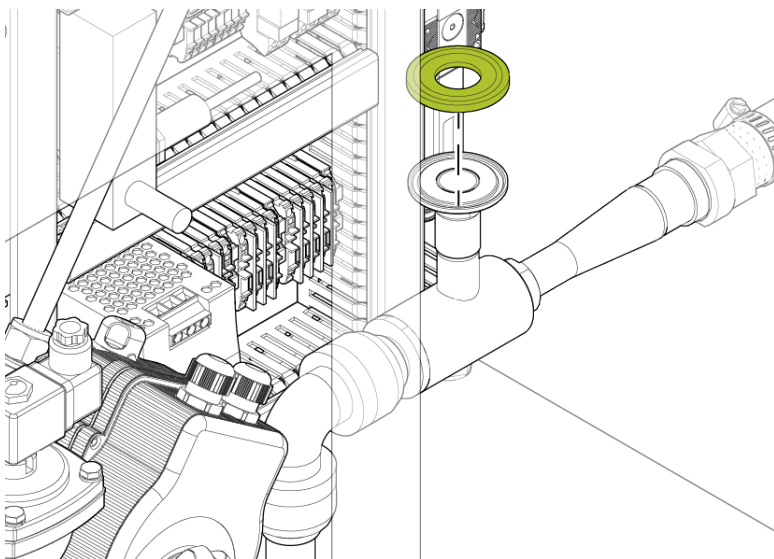

Figure 24: Optical XO sensor module orientation

- | | |
|---------------------------------------|----------------------|
| ① Internal piping from sampling probe | ③ Connector housing |
| ② Sample intake pipe | ④ Sample outlet pipe |

To attach the optical XO sensor module:

1. Make sure that the main power switch is in OFF position and disconnect the power supply cable.
2. Place a quick-clamp gasket on the pipe on top of the ejector chamber.



- Place a quick-clamp gasket on the sample intake pipe of the sensor module.

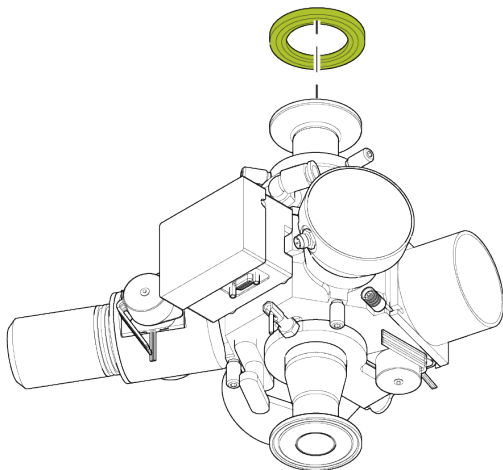

- Place the optical XO sensor module inside the enclosure. Make sure that the module is oriented correctly, with the signal cable port on the connector housing pointing down.

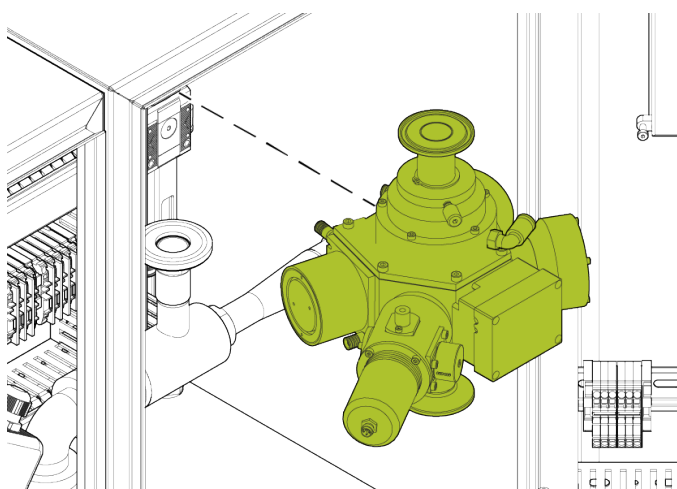

- Hold the sensor module in place with one hand. Use your other hand to secure the sample outlet pipe to the ejector chamber and the sample intake pipe to the internal piping with quick-clamp connectors.

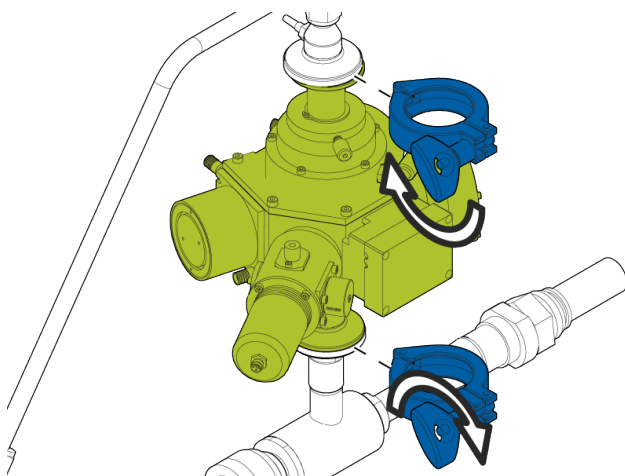

6. Connect the hose from the purge air flow meter to the purge air inlet.

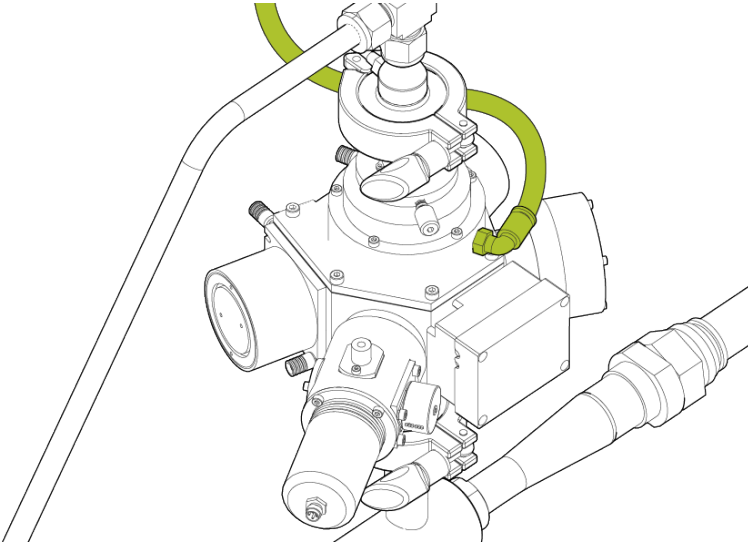

7. Make any necessary electrical connections on the sensor module.

For instructions on making electrical connections on the optical XO sensor module, see section **Connections on sensor module** in chapter **Electrical installation**.

6.4.5 Installing dust monitor to stack



It is recommended to connect the sampling probe to the device enclosure before connecting the dust monitor to the stack. However, you can connect the dust monitor to the stack before connecting the sampling probe to the enclosure, for example if the installation platform does not have much room.

To connect the dust monitor to the stack, you need:

- Bolts
- Hex nuts
- Flat washers
- Spring locking washers
- Wrench (24 mm [0.945 in])

The number of bolts, hex nuts and washers required depends on the type of flange used for the installation.

To connect the dust monitor to the stack:

1. Determine if the process that the device is installed on must be shut down before installation.
 - If the duct pressure is lower than the surrounding environment and the process does not produce any hot or dangerous gases, you can leave the process running.
 - If the duct pressure is higher than the surrounding environment and the process produces hot or dangerous gases, consider shutting the process down before installation.



It is the responsibility of the plant operator to decide whether a process can be running when the device is installed. Always follow the local and plant-specific safety standards when installing the device.

2. Make sure that the nozzle of the sampling probe is pointing to the direction the flue gas is flowing from. If necessary, adjust the nozzle.
3. Secure the rubber expansion joint to the process connection flange of the dust monitor using bolts.
 - Place a flat washer under each bolt on the dust monitor side of the installation.
 - Use spring locking washers with the hex nuts on the expansion joint side of the installation.
 - Tighten the bolts and hex nuts in a way that applies compression to the flange uniformly, starting with bolts on the opposite sides of the flange joint.
 - Select an appropriate tightening torque based on the bolts and hex nuts you are using.

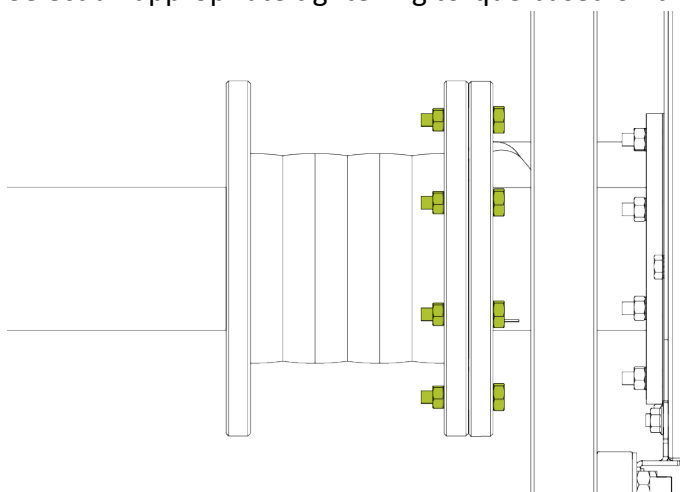

4. Remove the blind flange from the counter flange.
5. Insert the sampling probe through the counter flange into the stack.

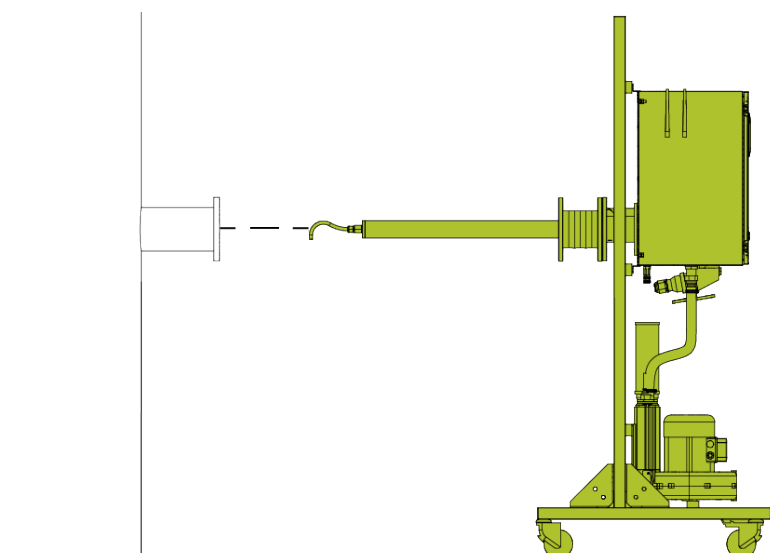

6. Secure the rubber expansion joint to the counter flange on the stack using bolts.

- Place a flat washer under each bolt on the expansion joint side of the installation.
- Use spring locking washers with the hex nuts on the counter flange side of the installation.
- Tighten the bolts and hex nuts in a way that applies compression to the flange uniformly, starting with bolts on the opposite sides of the flange joint.
- Select an appropriate tightening torque based on the bolts and hex nuts you are using.

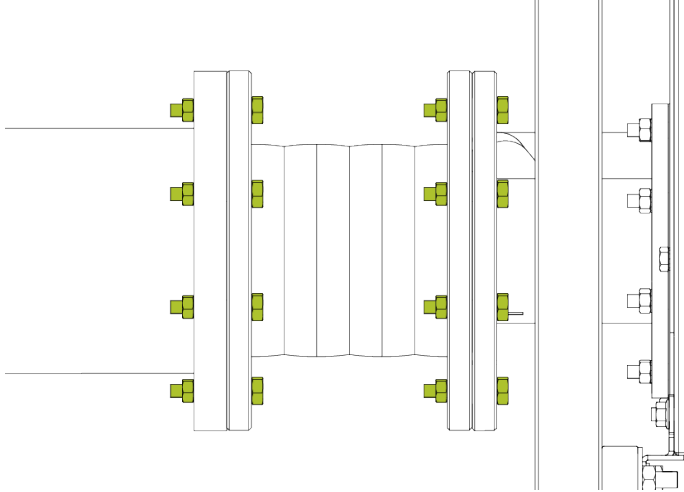

Adjusting sampling probe nozzle



CAUTION!

Risk of burns due to hot components

When the device is connected to a stack and the sampling is active, the sensor probe heats up. Touching the sampling probe or nozzle after the probe is removed from the process can result in a burn. Wear appropriate heat-resistant gloves and let the probe cool down before performing maintenance on the probe or adjusting the nozzle.

To adjust the nozzle, you need:

- Wrench (22 mm [0.866 in])

To adjust the nozzle:

1. Loosen the fastening nut holding the nozzle in place.

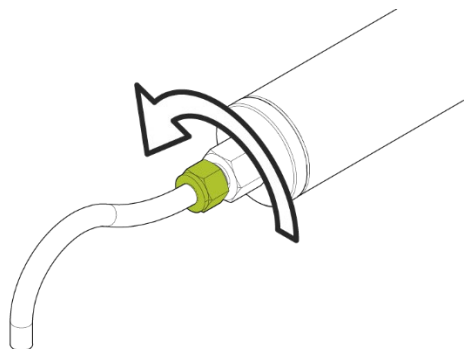

2. Rotate the nozzle until it is positioned correctly. The nozzle rotates 360°.

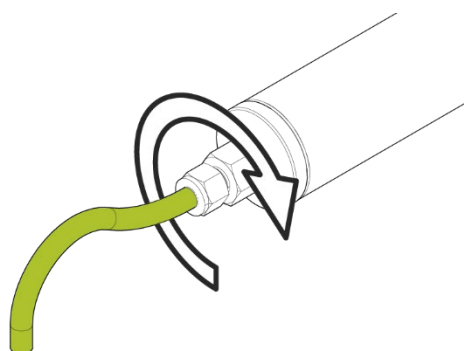

3. Tighten the fastening nut to secure the nozzle in its position.

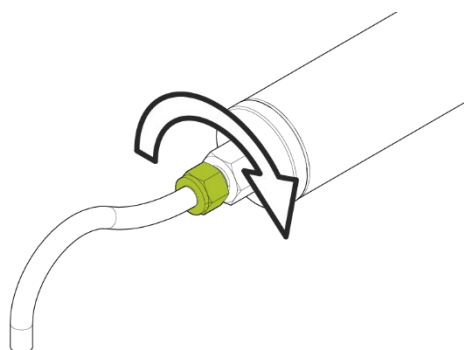

6.4.6 Installing sample air blower

To install the sample air blower to the mounting frame, you need:

- 2 hose clamps and a compatible screwdriver
- Wrench (19 mm [$\frac{3}{4}$ in])

Air tubes, tube fittings and fasteners are included in the delivery.

To install the sample air blower to the mounting frame and to connect it to the ejector:

1. Place the sample air blower on the bottom of the rack. Position it against the horizontal profile so that the bolt holes on the profile and the blower align.

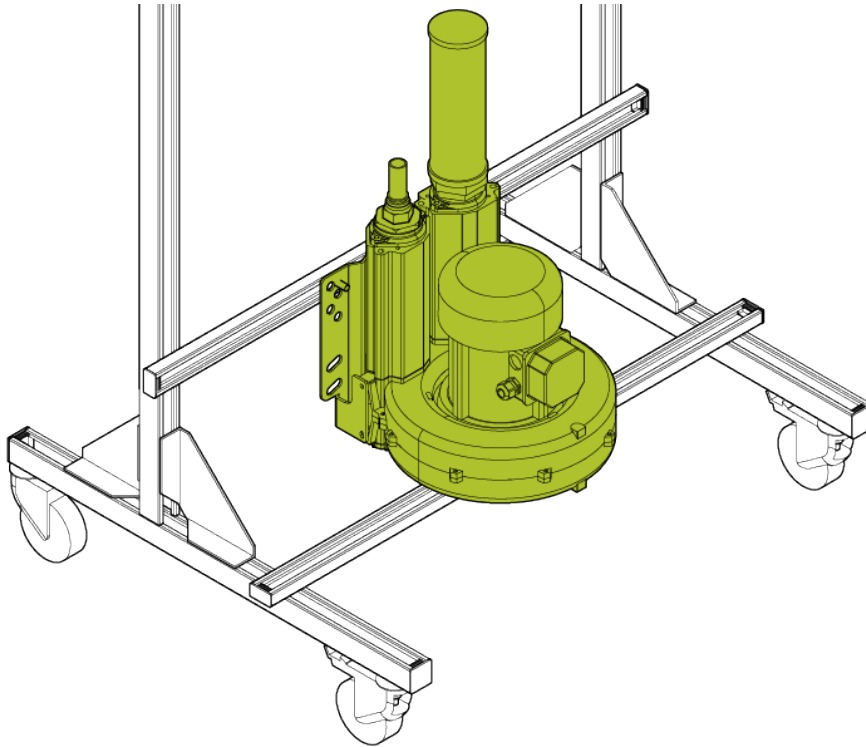

2. Insert a bolt through each bolt hole. Secure them in place with hex nuts.

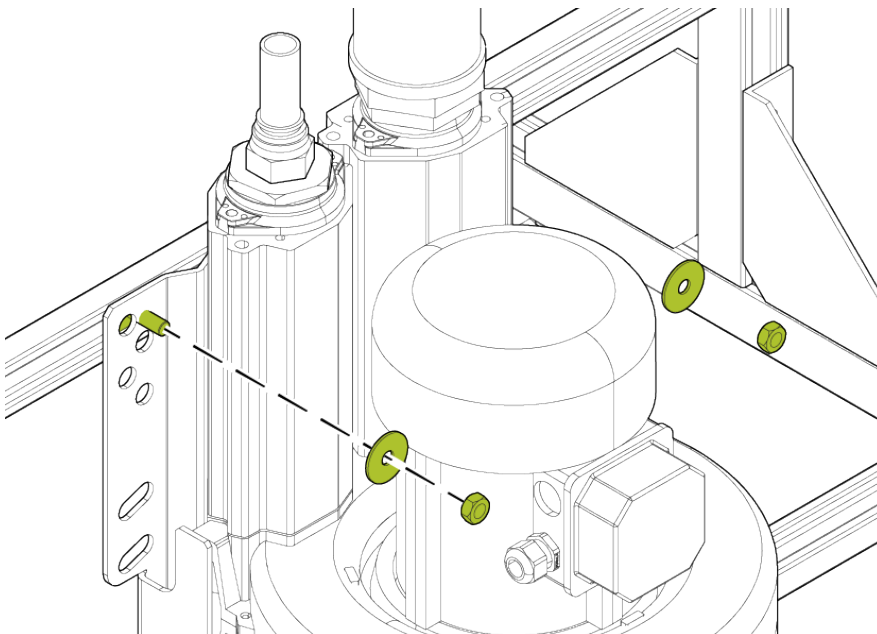

3. Connect the air supply tube to the air outlet of the sample air blower. Secure it in place using a hose clamp.

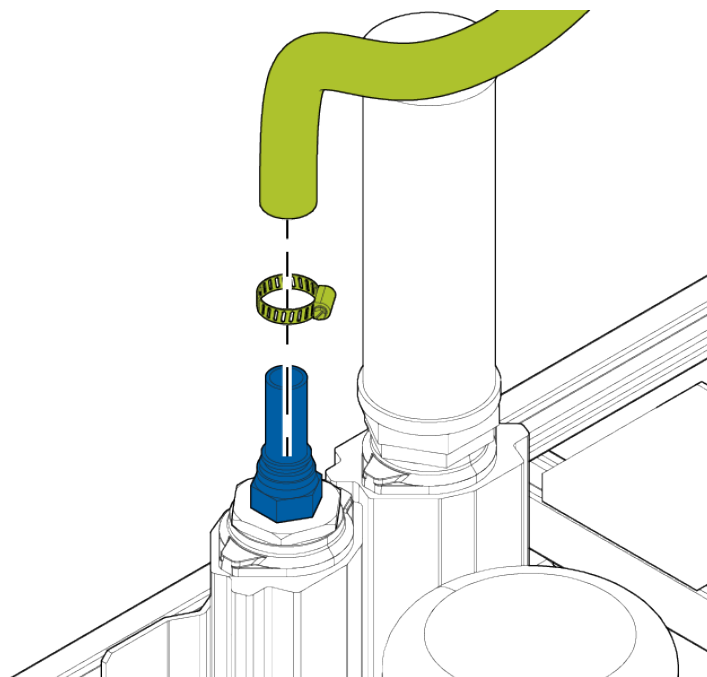

4. Connect the other end of the air supply tube to the air inlet on the bottom of the device enclosure. Secure it in place using a hose clamp.

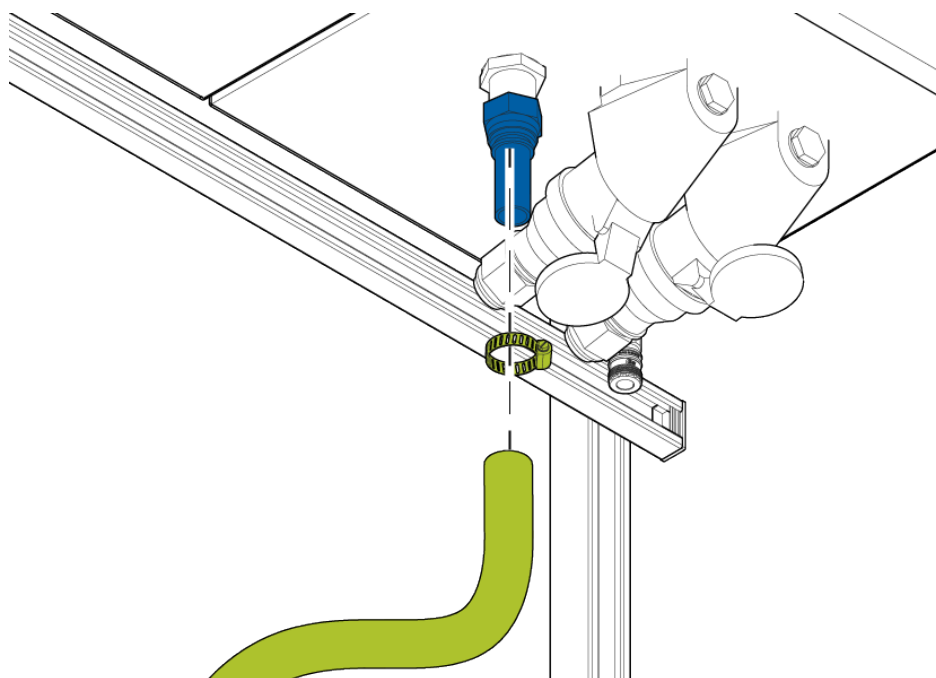

Installing exhaust tube

To connect the exhaust tube, you need:

- 2 hose clamps and a compatible screwdriver

Air tube, tube fittings and fasteners are included in the delivery.

To install the exhaust tube:

1. Connect one end of the exhaust tube to the ejector chamber air outlet. Connect the other end to the sample return inlet on the process connection flange.

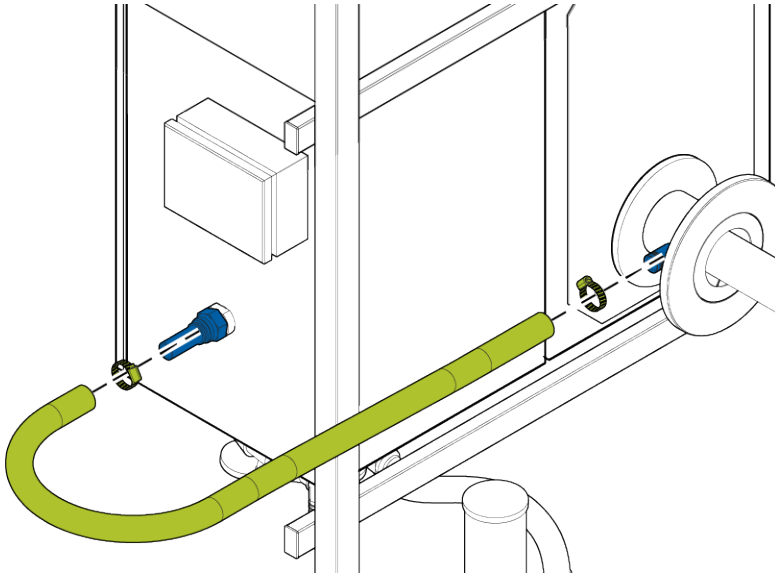

NOTICE

Make sure that the exhaust tube is level, with a slight downward incline towards the sample return inlet. If there is an upward incline at any point, there is a risk that condensed liquid stays in the tube. This can eventually cause blockage, for example in an outdoor installation when liquid mixed with dust freezes during the winter.

2. Secure the exhaust tube in place using hose clamps.

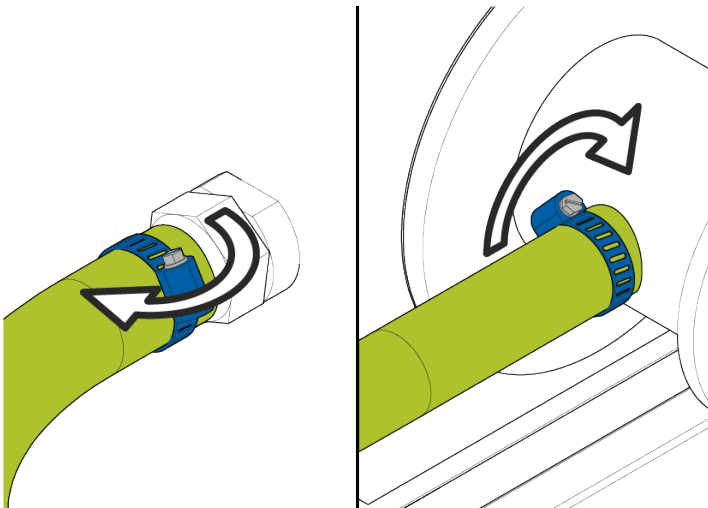

6.4.7 Connecting purge air supply

To enable air purge in the optical XO sensor module, you must have clean process air available at the installation site. The bottom of the device enclosure has a pneumatic connector that connects the process air to the regulator unit inside the enclosure.

Purge air hose and connector are not included in a standard delivery. The end-user must supply and assemble the air hose for purge air.

To connect the purge air supply, you need:

- Air hose that is suitable for supplying clean process air to the device
- DN 7.6 mm hose nipple connector

To connect purge air supply:

1. Fit the hose nipple connector to the purge air hose.
2. Snap the air hose to the pneumatic connector on the bottom of the enclosure.

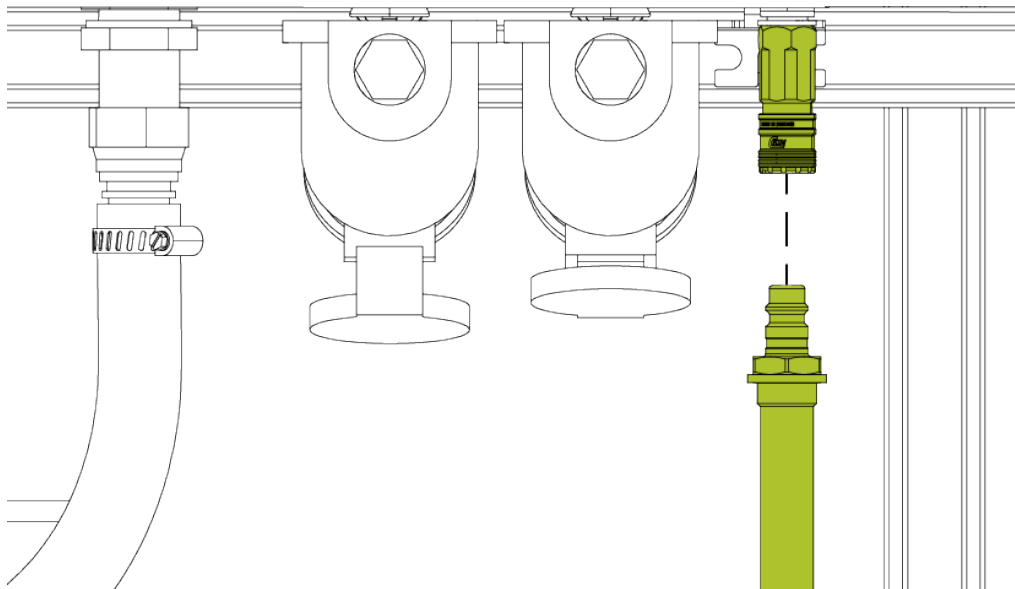

6.4.8 Installing weather protection roof



This procedure applies to an optional part or component that is not included in a standard delivery. If you want to retrofit your device with this part or component, contact the manufacturer or an authorized distributor.

To install the weather protection roof to the mounting frame, you need:

- Wrench
- Bolts
- Hex nuts
- Flat washers

To install the weather protection roof to the mounting frame:

1. Place the weather protection roof on top of the device enclosure. Position the mounting brackets against the vertical beams of the mounting frame. Align the bolt holes of the mounting brackets with the holes on the mounting frame.

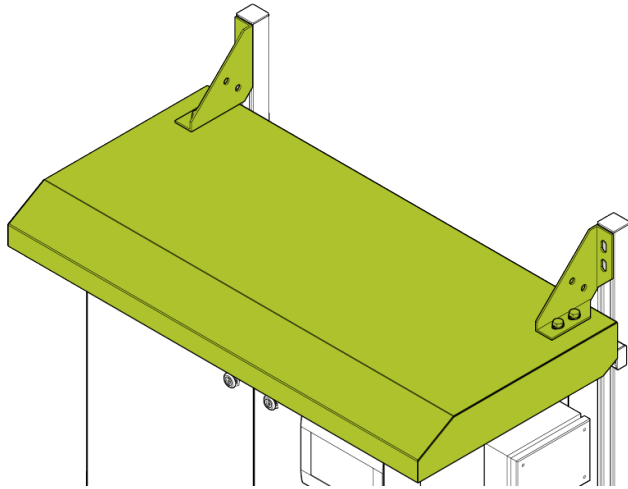

2. Insert a bolt through each bolt hole. Secure them in place with hex nuts.

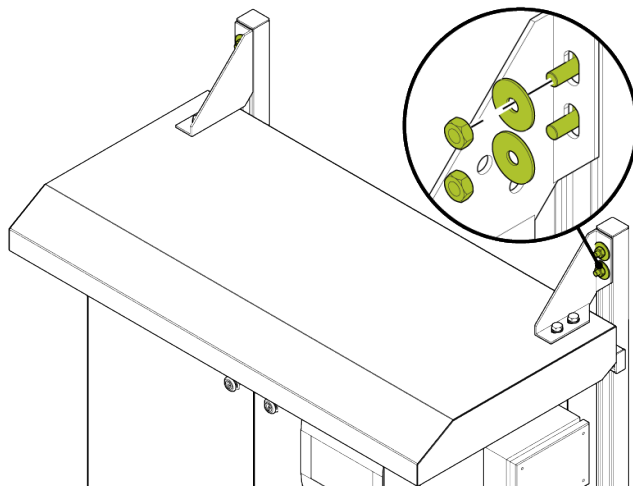

6.4.9 Installing fan heater and thermostat



This procedure applies to an optional part or component that is not included in a standard delivery. If you want to retrofit your device with this part or component, contact the manufacturer or an authorized distributor.

To install the thermostat and fan heater:

1. Install the DIN rail between the cabinets of the enclosure. The enclosure has pre-drilled holes for installing the DIN rail.

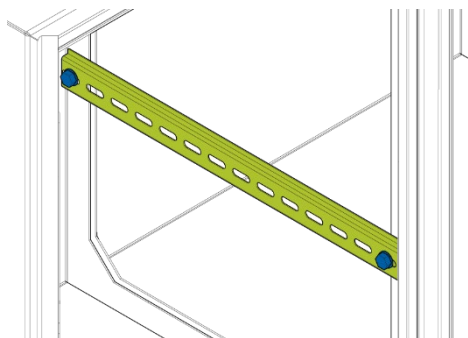

2. The DIN rail has two lines that indicate the correct position of the heater. Mount the fan heater on the DIN rail between these lines.

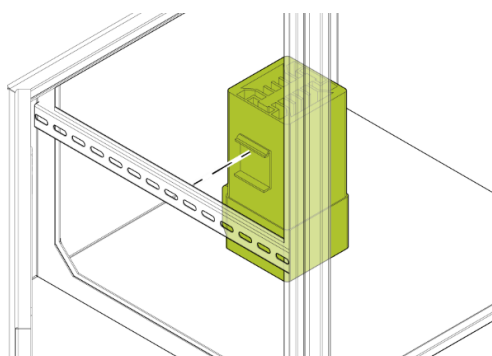

3. Mount the thermostat on the DIN rail located below the panel PC on the right-side door of the enclosure.

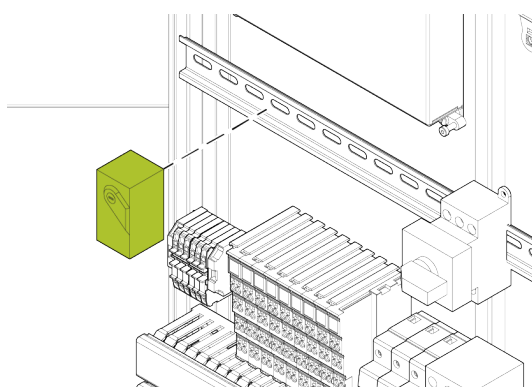

4. Connect the cables for the fan heater and thermostat.

For instructions on making electrical connections for the heater and thermocouples, see section **Connections on fan heater and thermostat** in chapter **Electrical installation**.

7 Electrical installation



Read chapter “Safety” carefully before making any electrical connections to the device.

7.1 Electrical safety



Wear protective glasses when making electrical connections on the device.

WARNING!



Electric shock hazard

Faulty electrical installations, too high line voltage or incorrect operation of the device can result in an electric shock. Only trained and qualified personnel can install, commission, operate and perform maintenance on the device.

To ensure safe installation of electrical connections:

- Power down the device and disconnect it from the power supply when you are making electrical connections, when you intend to perform maintenance on it, or in the event of malfunction.
- Connect the device to line voltage only if the power supply specifications correspond to the data on the identification label of the device.
- Make sure that all equipment is properly grounded.
- Stand on an insulating pad and check components only with one hand.
- Never work alone on electrical connections.



You must install the cables according to all applicable local safety codes.

7.2 Cable types



Make sure that the cables are suitable for the environment and industrial application where the device is used. The cables must meet and be installed according to all applicable local safety standards.

Most electrical connections inside the device enclosure are already made at the factory. However, the end-user must supply the cables used with analog mA output and digital outputs.

When choosing cables, consider the following:

- Maximum conductor size is 2.5 mm².
- Use a shielded cable if possible. Connect the cable shield to ground on one end only.
- The cables must withstand up to 70 °C (158 °F) continuous temperature.
- For digital outputs, use instrumentation cables with resistance of approximately 80 Ω/km.

The device uses spring type terminal blocks for electrical connections.

7.3 Power sockets

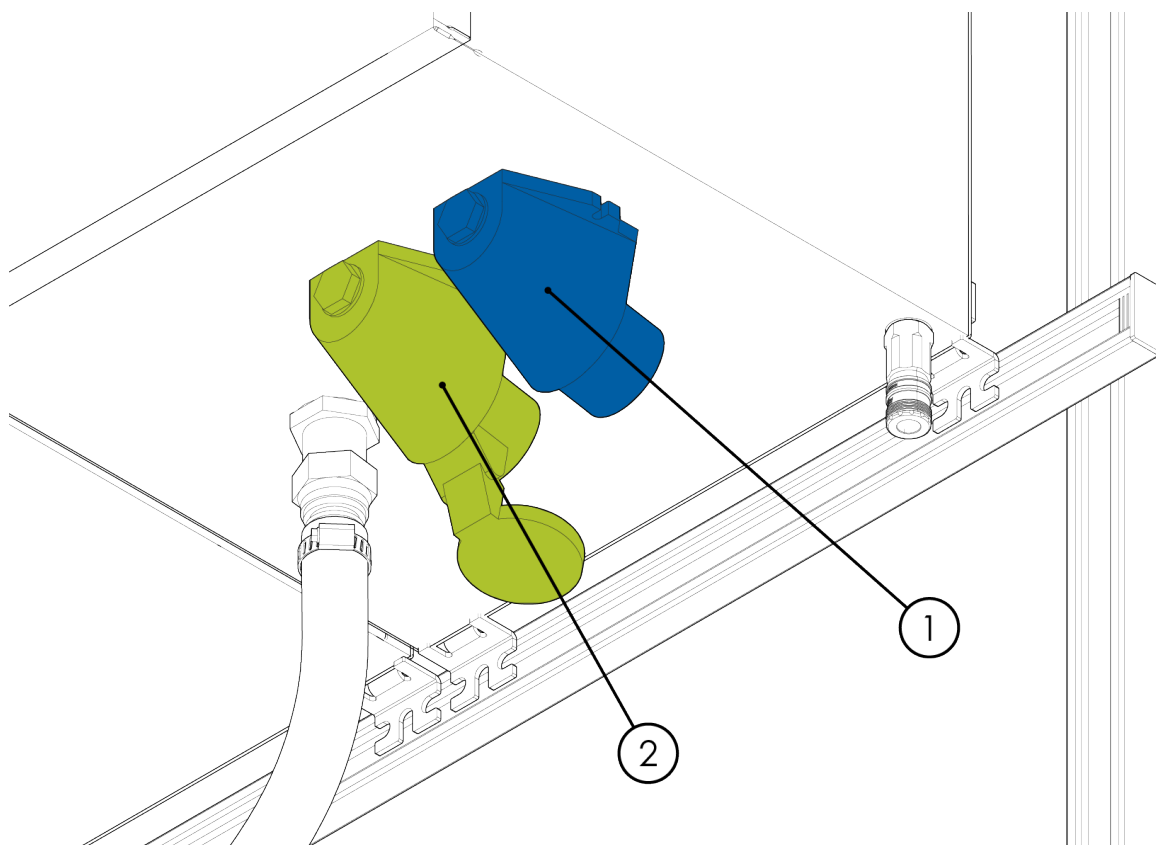

Figure 25: Power sockets on the enclosure

-
- | | | | |
|---|---------------------------|---|--|
| ① | Power supply socket, male | ② | Power outlet for sample air blower, female |
|---|---------------------------|---|--|
-

7.3.1 Power supply socket

WARNING!



Electric shock hazard

Connecting the device to an incompatible power supply can result in an electric shock. Connect the device to a power supply only if it corresponds to the data on the identification label.



The power supply cable must be rated for 400 V / 16 A.

To connect the device to power supply:

1. Make sure that the main power switch is in OFF position.
2. Make sure that the power supply unit can provide a 400 V 3 Phase voltage and 16 A current.
3. Connect the power cord from the power supply to the male power supply socket.

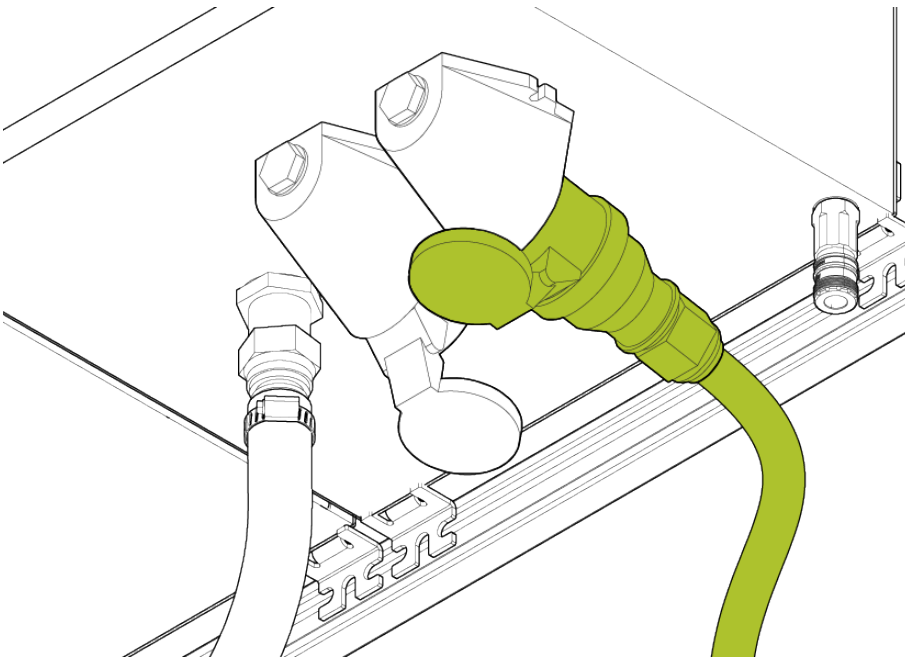

4. Turn the main power switch to ON position.

7.3.2 Power outlet for sample air blower



A single power supply powers the whole device and all auxiliary equipment. The dedicated power outlet can only supply power to the sample air blower if the power supply unit is connected to the power supply socket.

To connect the sample air blower to power socket:

1. Make sure that the main power switch is in OFF position.
2. Connect the power cord from the blower to the power outlet socket located between the sample air inlet and the power supply socket.

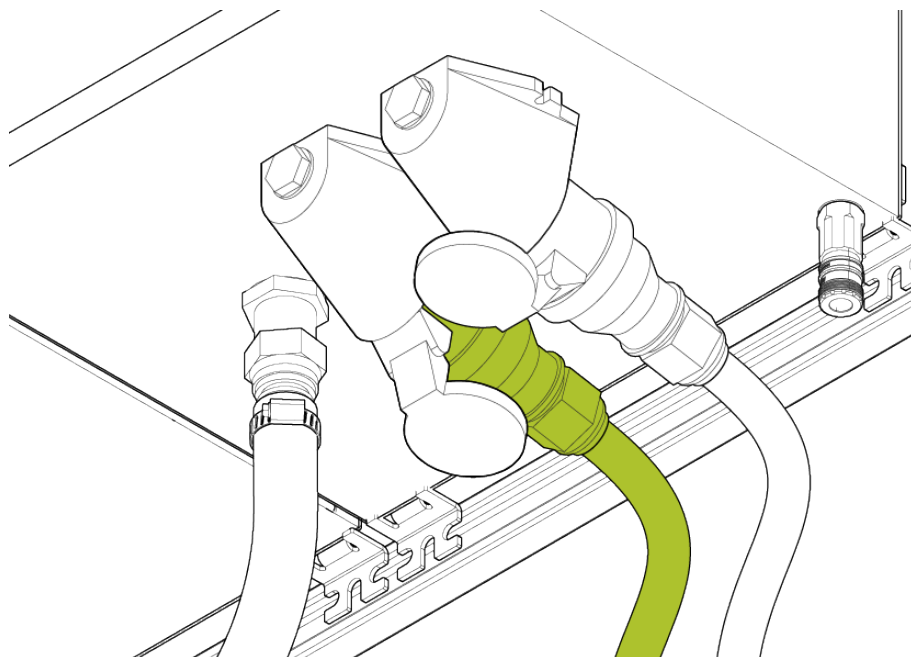

7.4 Connections on sampling probe

The sampling probe is equipped with a sample heater and two thermocouples. The wires that connect the heater and thermocouples to the internal electronics are already connected to the probe upon delivery (Figure 26).

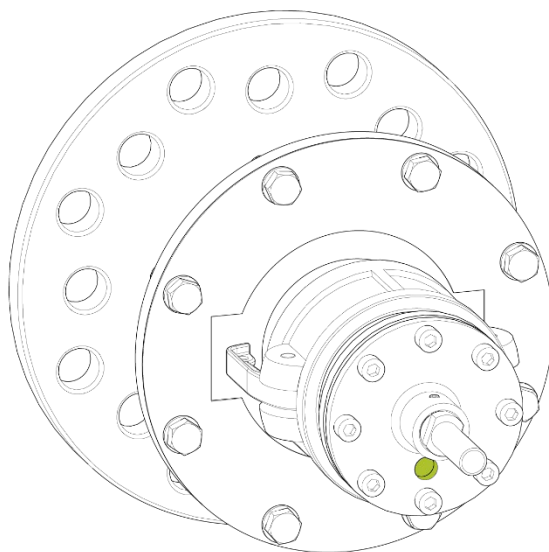

Figure 26: Sampling probe thermocouples and heater connection on the base of the sampling probe

The person responsible for commissioning connects the sample heater and thermocouple wires to the correct terminal blocks inside the device enclosure. The terminals are located on the top rail in the right half of the enclosure (Figure 27). All other necessary electrical connections for the operation of the sampling probe are done at the factory.

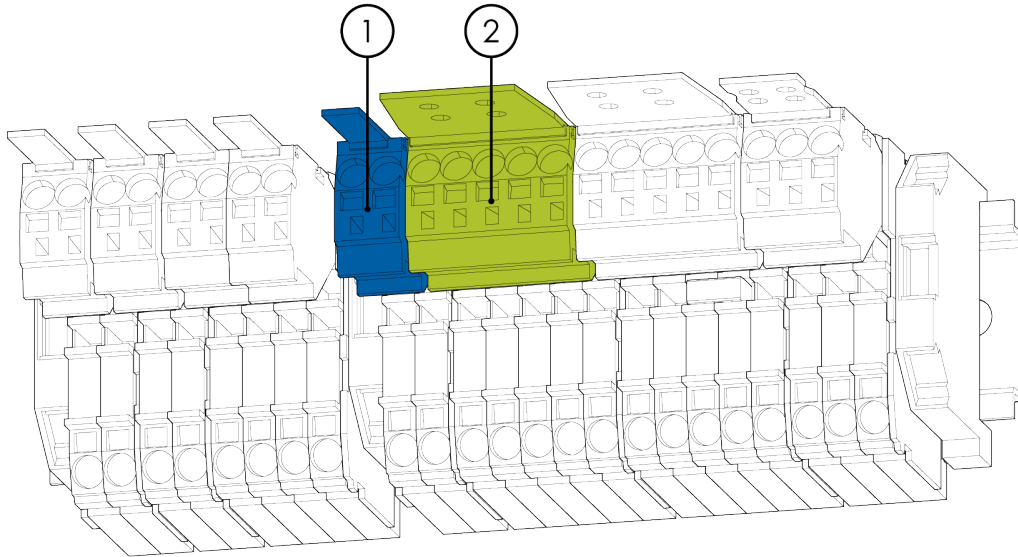
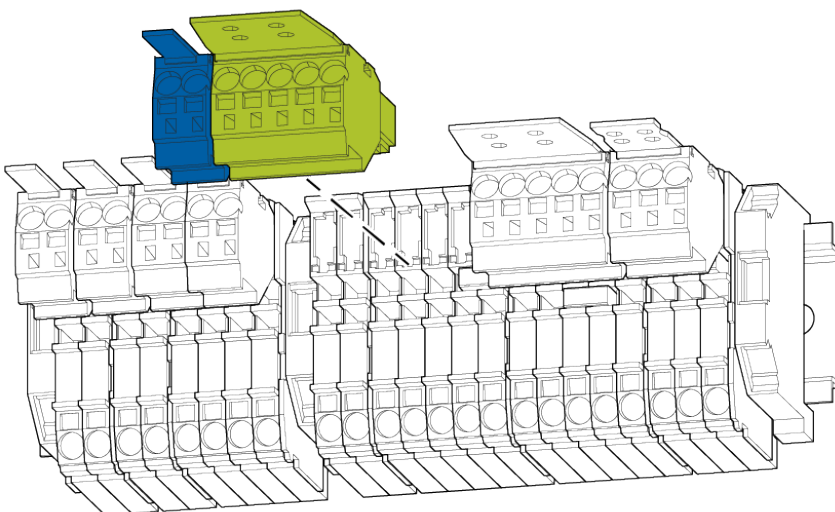

Figure 27: Sampling probe thermocouple and heater connections on the terminal block

- | | |
|--------------------------------------|-------------------------|
| ① Sampling probe thermocouple, back | ③ Sampling probe heater |
| ② Sampling probe thermocouple, front | |

To make the electric connections for the sampling probe:

1. Make sure that the main power switch is in OFF position and disconnect the power supply cable.
2. Connect the cables from the sampling probe to the terminal block inside the enclosure. The cables are pre-connected to the terminal connectors at the factory.



7.5 Connections on sensor module

The optical XO sensor module has two connectors for cables (Figure 28). The person responsible for commissioning connects the fixed D-Sub cable and the pre-amplifier signal cable from the terminal block to the sensor module. All the other necessary electrical connections for the operation of the sensor module are done at the factory.

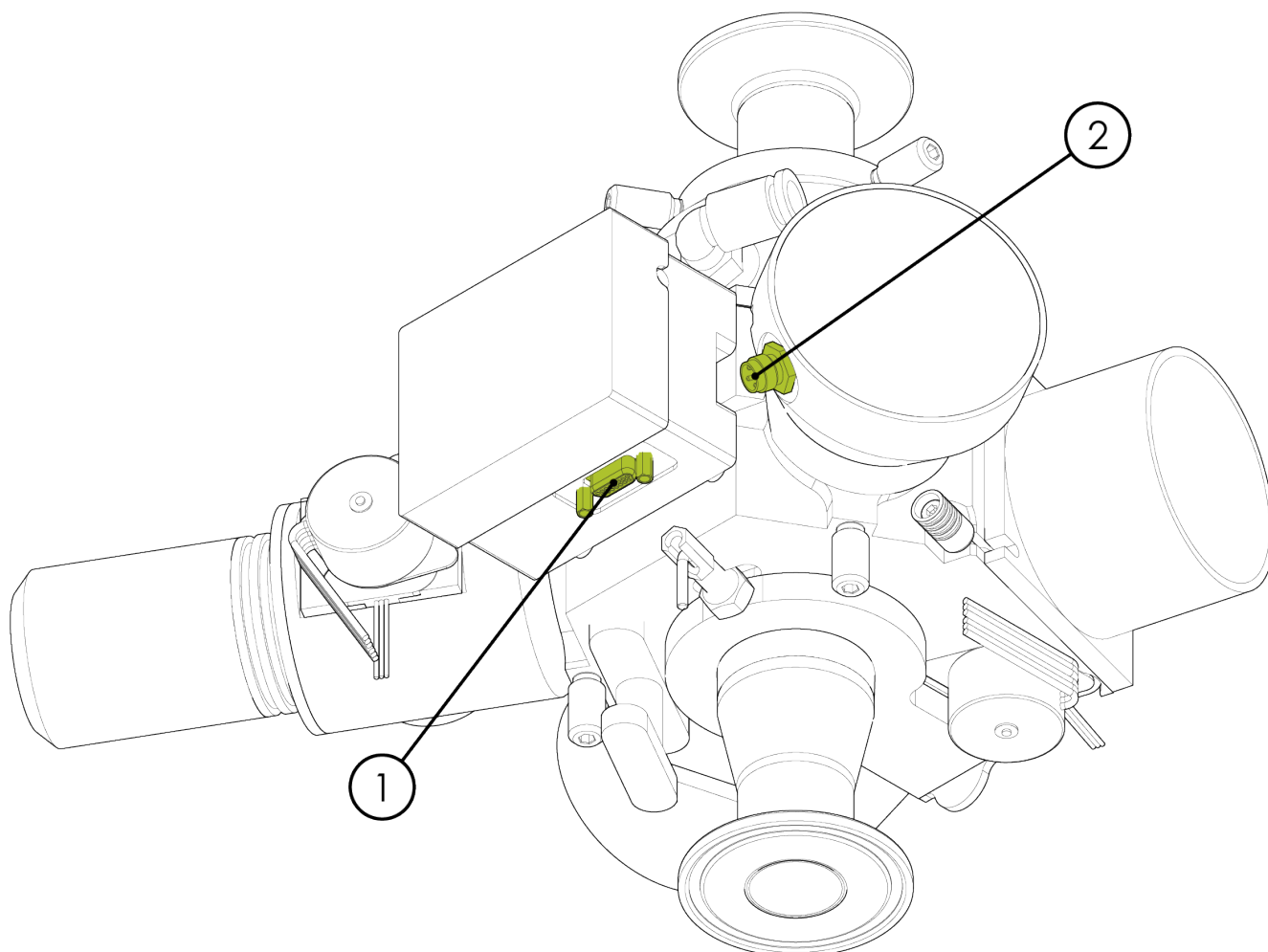
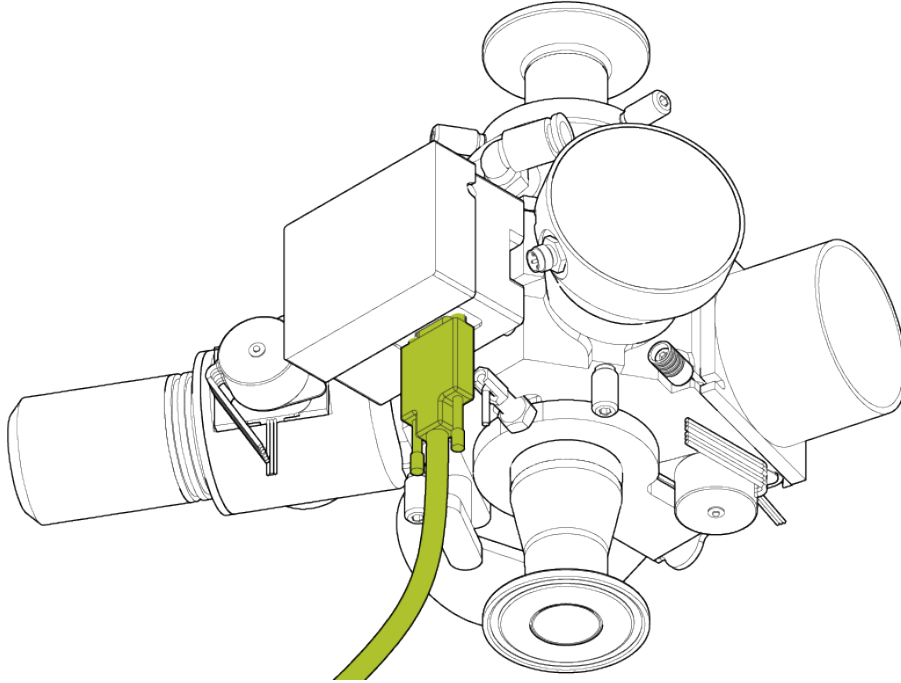

Figure 28: Connectors on the optical XO sensor module

- | | |
|---|--|
| ① | 15 Pin D-Sub cable for the stepper motor control signals |
| ② | 4-wire cable for pre-amplifier power and signals |

To make the electric connections for the sensor module:

1. Make sure that the main power switch is in OFF position and disconnect the power supply cable.
2. Connect the fixed cables from the terminal block to the sensor module:
 - Connect the D-Sub cable from the terminal block to the connector housing.



- Connect the 4-wire signal cable from the terminal block to the pre-amplifier.

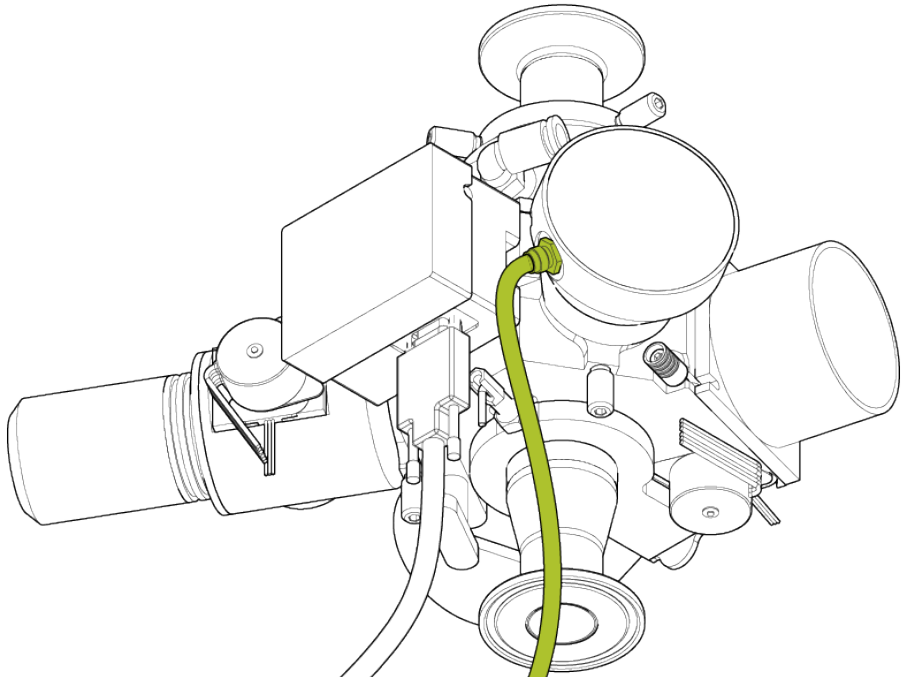

7.6 Connections on fan heater and thermostat



This procedure applies to an optional part or component that is not included in a standard delivery. If you want to retrofit your device with this part or component, contact the manufacturer or an authorized distributor.

The person installing the fan heater and thermostat connects the wires to the correct terminal blocks inside the device enclosure. The terminals are located on the bottom rail in the right half of the enclosure (Figure 29).

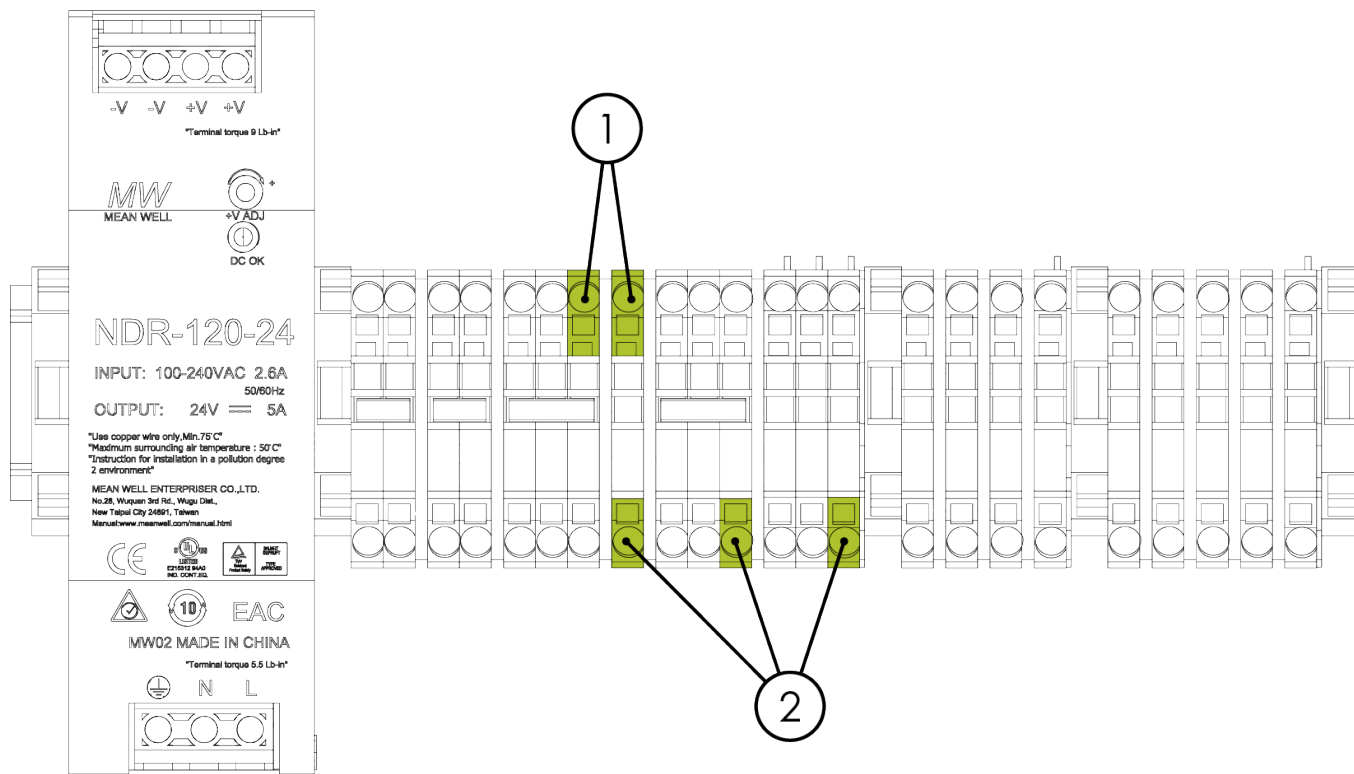

Figure 29: Fan heater and thermocouple connections on the terminal block

① Thermostat

② Fan heater

To make the electric connections for the fan heater and thermostat:

1. Make sure that the main power switch is in OFF position and disconnect the power supply cable.
2. Connect the cables from the thermostat to the bottom terminal block inside the enclosure.
3. Connect the cables from the fan heater to the bottom terminal block inside the enclosure.

7.7 Analog and digital outputs

7.7.1 Connection box

There is a dedicated connection box for analog mA output and digital outputs outside the device enclosure. The connection box is located above the ejector chamber air outlet on the right side of the enclosure (Figure 30).

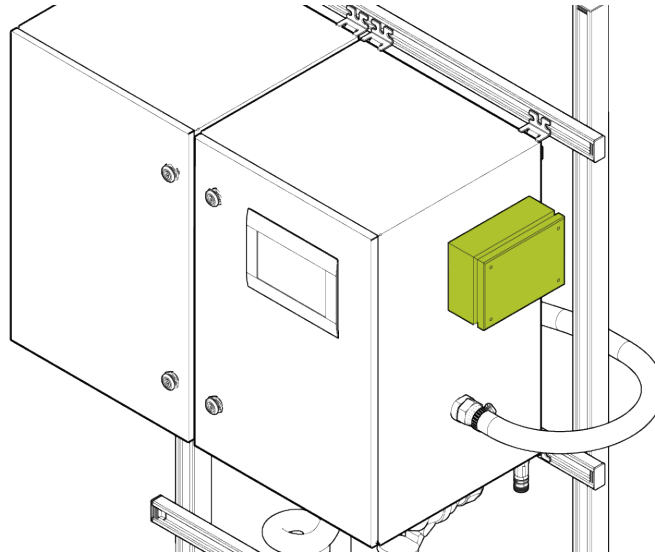

Figure 30: Connection box above the ejector chamber air outlet

The cover of the connection box is secured with four screws (Figure 31).

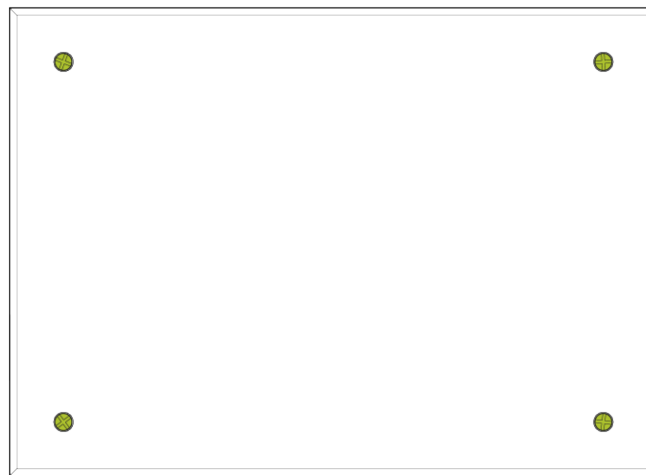

Figure 31: Screws on the connection box cover

The connection box houses two terminal blocks. One terminal block contains two connection points for the analog mA loop, and the other has 16 connection points for digital outputs. The wires from the device electronics are already connected through a hole on the side of the enclosure and the connection box.

The bottom of the connection box has two cable glands that you can use to route the signal cables out of the connection box. See Figure 32 for overview of the cable glands and connection points.

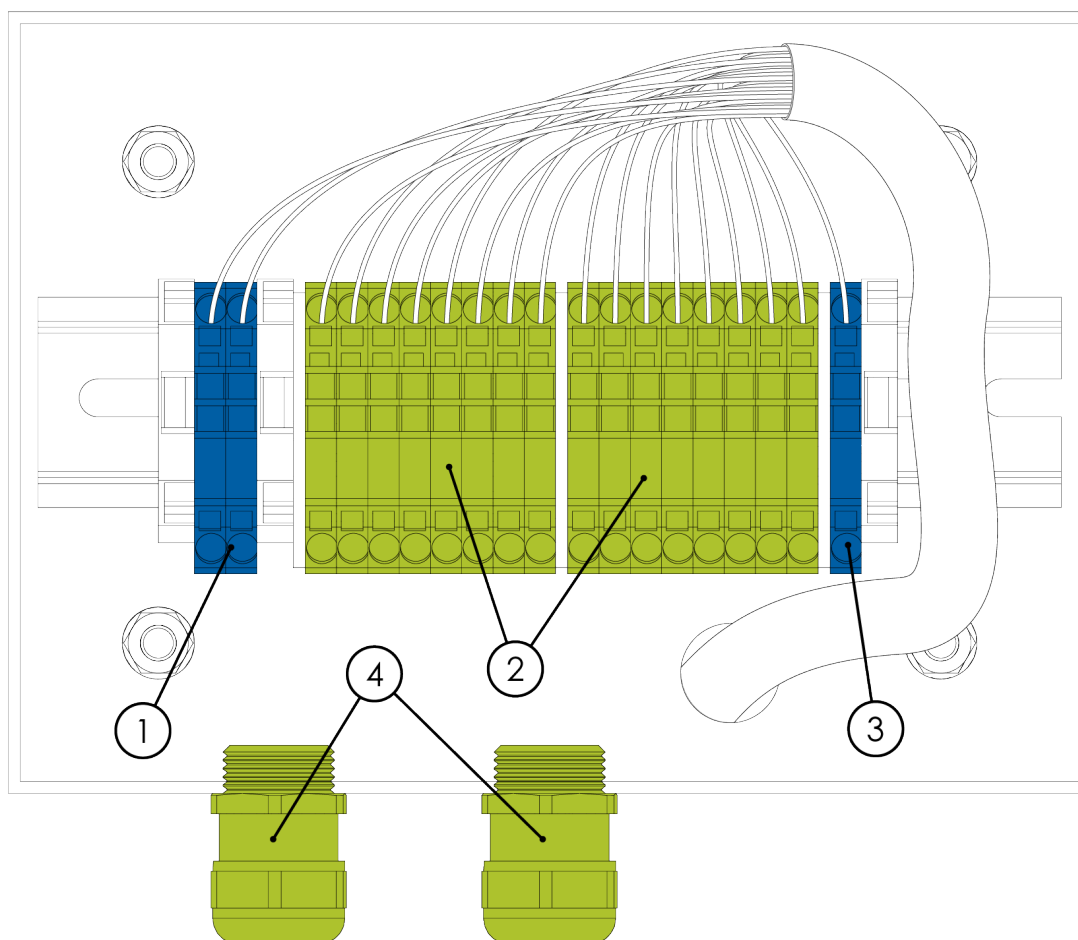

Figure 32: Connection box

① mA loop	③ Ground connection
② Digital outputs	④ M16 cable glands

7.7.2 Connecting analog mA output

The device has a single active and isolated mA output that uses industry standard 4 ... 20 mA signal range for indicating measurement value. Maximum resistance for the mA loop is 350 Ω . The mA output is intended to be used as a long-range analog data transfer in industrial applications.

The mA output is in the connection box that is located outside the device enclosure.

To connect the mA output, you need:

- 2-wire signal cable
- Screwdriver
- Wrench (20 mm [0.7874 in] or adjustable)

To connect the mA output:

1. Remove the screws that hold the connection box cover in place. Open the connection box.
2. Open the cable gland using a wrench.

3. Push a screwdriver into the square opening next to the output that you want to connect to your automation system. This applies pressure to the locking spring and opens the terminal point.

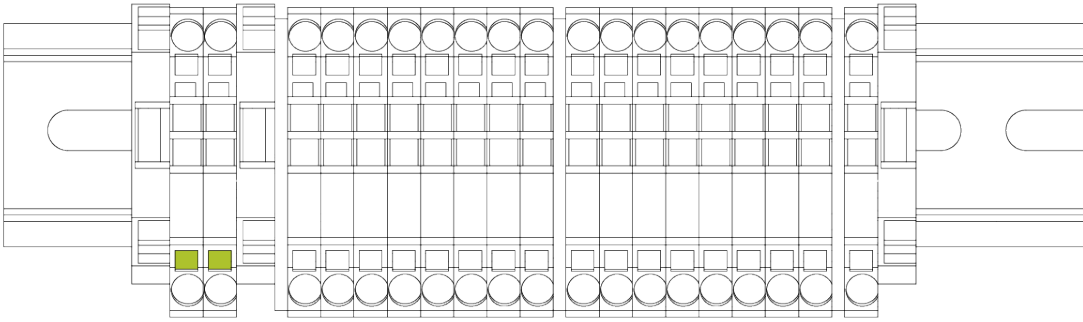

4. Insert a signal cable into the round terminal point.

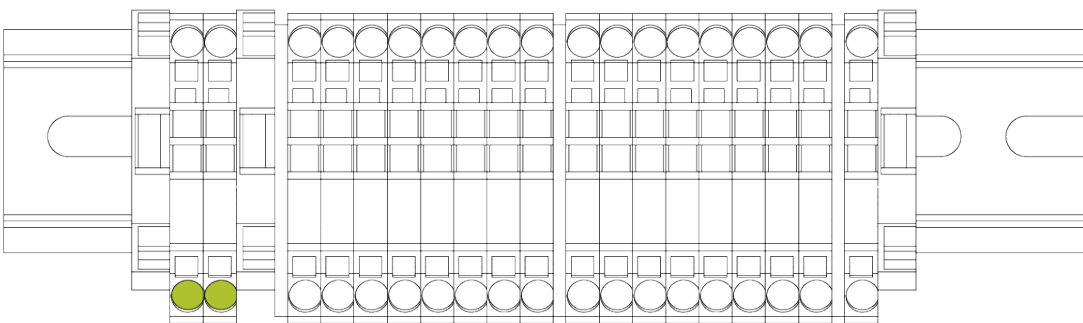

5. Remove the screwdriver from the square opening. This releases the locking spring and secures the signal cable in place.

7.7.3 Connecting digital outputs

The device has two 8-channel digital output terminals inside the enclosure. Both terminals have eight LED lights that correspond to each output channels. When a digital output is active, the corresponding LED lights up.

The digital outputs are factory-wired from the enclosure to a connection box that is located outside the device enclosure. The left-side terminal delivers signals related to the status and operation of the sampling line, valves and heater elements. The right-side terminal delivers signals related to the status and operation of the electronics and optical XO sensor module. Outputs on the connection box are labeled 1 to 16.

You can connect the channels to an automation control system to indicate the status of the device or maintenance relays. Each channel can deliver 24 V DC, 500 mA signal. Use instrumentation cables with resistance of approximately 80 Ω /km.

Table 4 shows the function of each channel on both digital output terminals.

Table 4: Description of digital output channels in the connection box

Output	Sampling terminal (left)	Output	XO module terminal (right)
1	Active when the heater element of the sampling probe is ON.	9	Active when data logging is ON.
2	Active when “Continue sampling after power failure” setting is enabled.	10	Active when automatic zero point check is active.
3	Active when the deviation in flow rate is outside the permitted range in relation to the flow value setpoint.	11	Active when the manual span check is in progress.
4	Active when the XO intake temperature is outside the permitted range.	12	Active when either stepper motor is unable to return to its home position.
5	Active when the device performs a cleaning cycle.	13	Active when the device performs periodic self-diagnostics.
6	Active when the flue gas valve is closed and the sampling is not active.	14	Active when there is a fault related to the operation of the stepper motors.
7	Active when the compressor is ON and pressurizes the pressure vessel.	15	Active when there is a fault related to the optical components of the sensor module
8	Active when the purge air flow is interrupted.	16	Active when maintenance relay 8 is ON. The maintenance relay activates when the device performs periodic self-diagnostics, during the cleaning pulse and when logged in as Admin or Service user.

To connect the digital outputs, you need:

- 1-wire signal cable for each digital output
- Screwdriver
- Wrench (20 mm [0.7874 in] or adjustable)

To connect the digital outputs:

1. Remove the screws that hold the connection box cover in place. Open the connection box.
2. Open the cable gland using a wrench.
3. Push a screwdriver into the square opening next to the digital output that you want to connect to your automation system. This applies pressure to the locking spring and opens the terminal point.

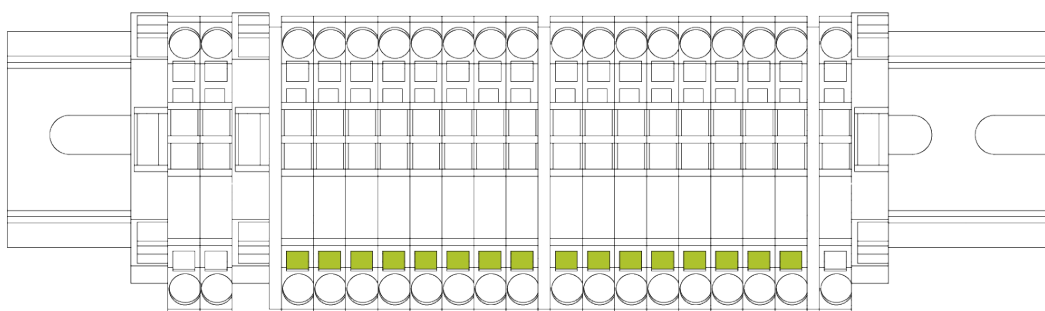

4. Insert a signal cable into the round terminal point.

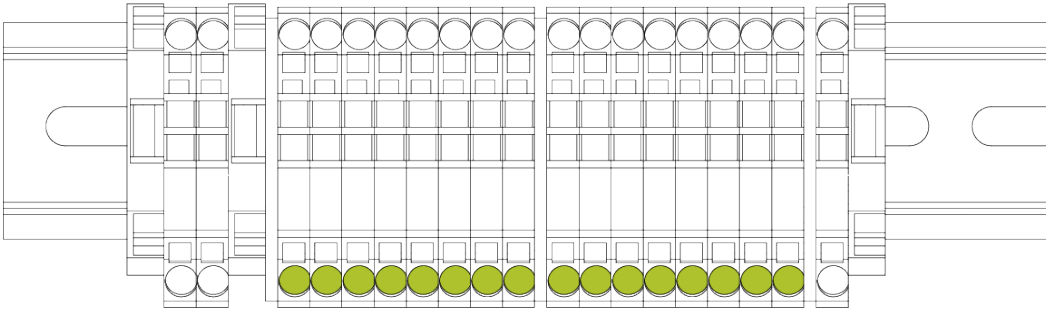

5. Remove the screwdriver from the square opening. This releases the locking spring and secures the signal cable in place.
6. Repeat this for each digital output that you want to connect.
7. Route the signal cable out of the enclosure through one of the cable entries located on the bottom of the connection box.

8 User interface



The user interface displays live pressure and temperature readings from the system. If a thermocouple is not connected, the user interface displays “NoConn” instead of a temperature value.

8.1 MAIN view

The startup view of the user interface contains information about user access level, device status and local time, and buttons to access different menus.

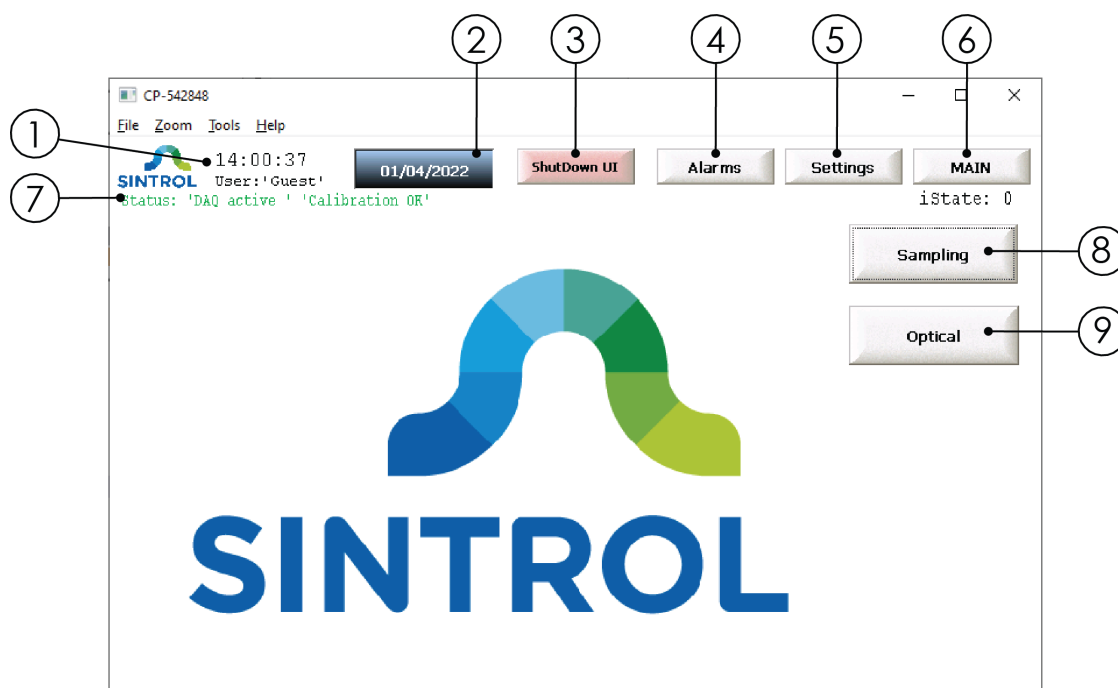

Figure 33: MAIN view of the user interface

①	Current time and user level	⑥	Returns to MAIN view
②	Current date (mm/dd/yyyy)	⑦	DAQ active = USB data logging running Calibration OK = Startup successful
③	Shuts down the user interface. Measuring continues in the background.	⑧	Sampling view displays an overview of the sampling line, with information like flue gas, heater and pressure vessel temperature, and valve status.
④	Alarms view shows maintenance and alarm relay statuses and displays any active error messages.	⑨	Optical view displays a live graph that indicates an average dust concentration
⑤	You can change the user level in Settings view, and access sampling and sensor module settings.		

8.2 Sampling view

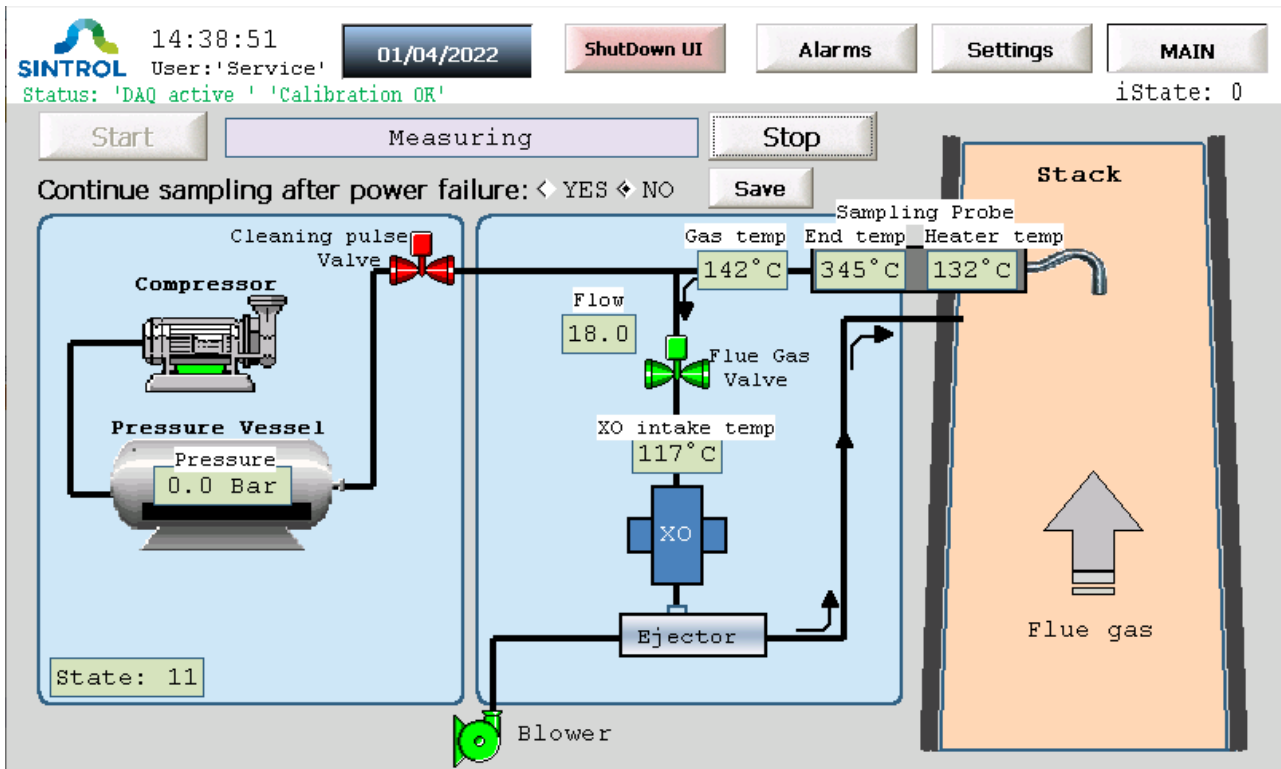

Figure 34: Sampling view

You can start or stop the measurement sampling cycle from Sampling view using the buttons on the upper side of the screen. The view displays a diagram that illustrates how different parts of the sampling line interact with each other.

During normal operation, the diagram provides real-time feedback on valve status, temperature readings, pressure inside the pressure vessel and flow rate. If there is no thermocouple connected, the user interface displays “NoConn” instead of a temperature value. Sampling view shows closed valves as red, and open valves as green.

8.3 Optical view

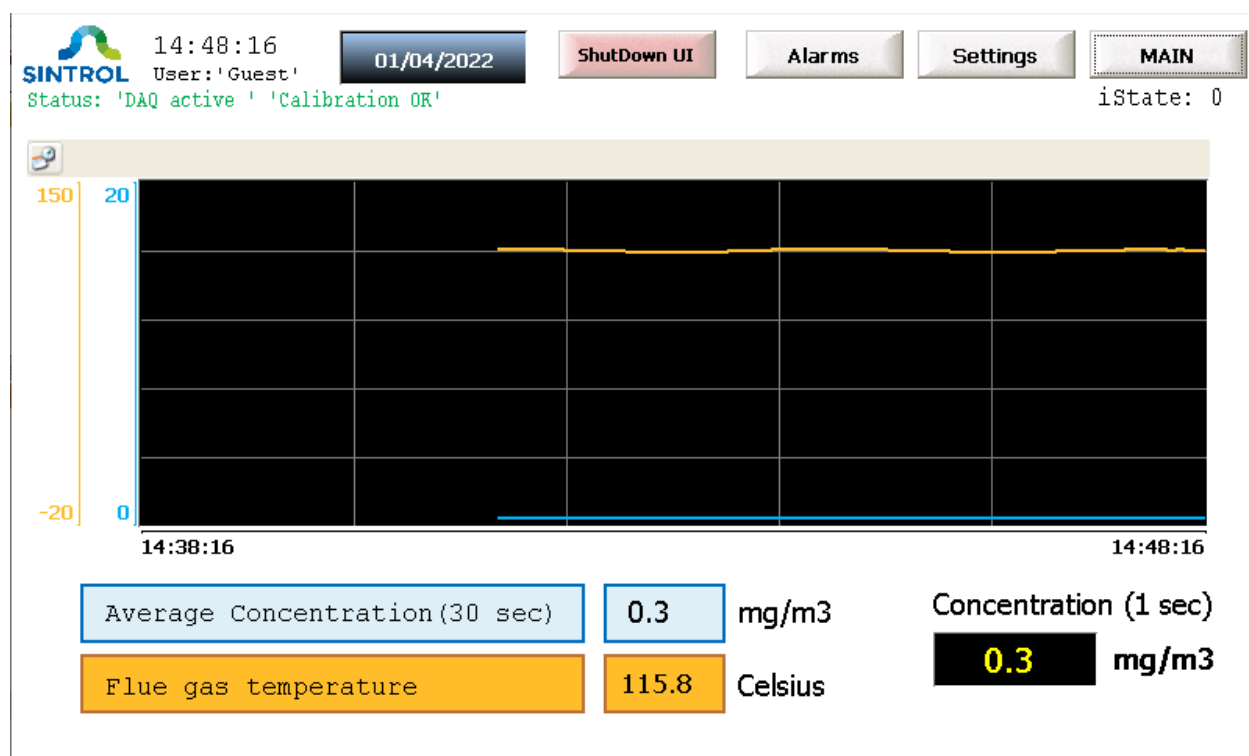

Figure 35: Optical view

Optical view displays a live graph that indicates an average dust concentration based on the selected signal averaging filter. Signal averaging filter determines the period from which the device calculates the average dust concentration. For example, with the signal averaging filter value of 30 seconds, the displayed measurement result is the moving average of the past 30 seconds. The dust concentration is shown in mg/m³.

Optical view also shows the current flue gas temperature. This is helpful when assessing the possibility of the flue gas containing condensed droplets. If there is no thermocouple connected, the user interface displays “NoConn” instead of a temperature value.

The sample gas is typically between 110 ... 120 °C (230 ... 248 °F) so that the gas temperature is above the condensation point of water. If the gas contains acids with higher condensation point, it can be necessary to increase the sample gas temperature even higher.

The flue gas must not contain droplets because the optical sensor does not distinguish liquid droplets from dust particles. Additionally, wet dust can stick to the optics, which can eventually damage them and lead to incorrect measurement results.

8.4 Alarms view



Figure 36: Alarms view

Alarms view displays the status of three alarm relays that are used to communicate the internal status of the device on the user interface. In normal operation, all three relays are OFF. Maintenance relay 8 is always ON when logged in as Service or Admin user.

Function of each alarm relay is described in Table 5.

Table 5: Functions of alarm and maintenance relays

Relay	Function
Alarm relay 6	Indicates an alarm related to the operation of the stepper motors.
Alarm relay 7	Indicates an alarm related to the optical components of the sensor module, for example contamination.
Maintenance relay 8	Indicates that the device is in Maintenance mode. In this mode, the device runs periodical operational and self-diagnostics checks, and does not measure the dust concentration. Maintenance relay is always ON when logged in as Service or Admin user. Maintenance relay is OFF only when logged in as Guest user.

In case there is an alarm or an error, the device displays and error message in the Alarms view. For description of error messages, see section **Error messages** in chapter **Troubleshooting**.

8.5 Settings view and user access levels

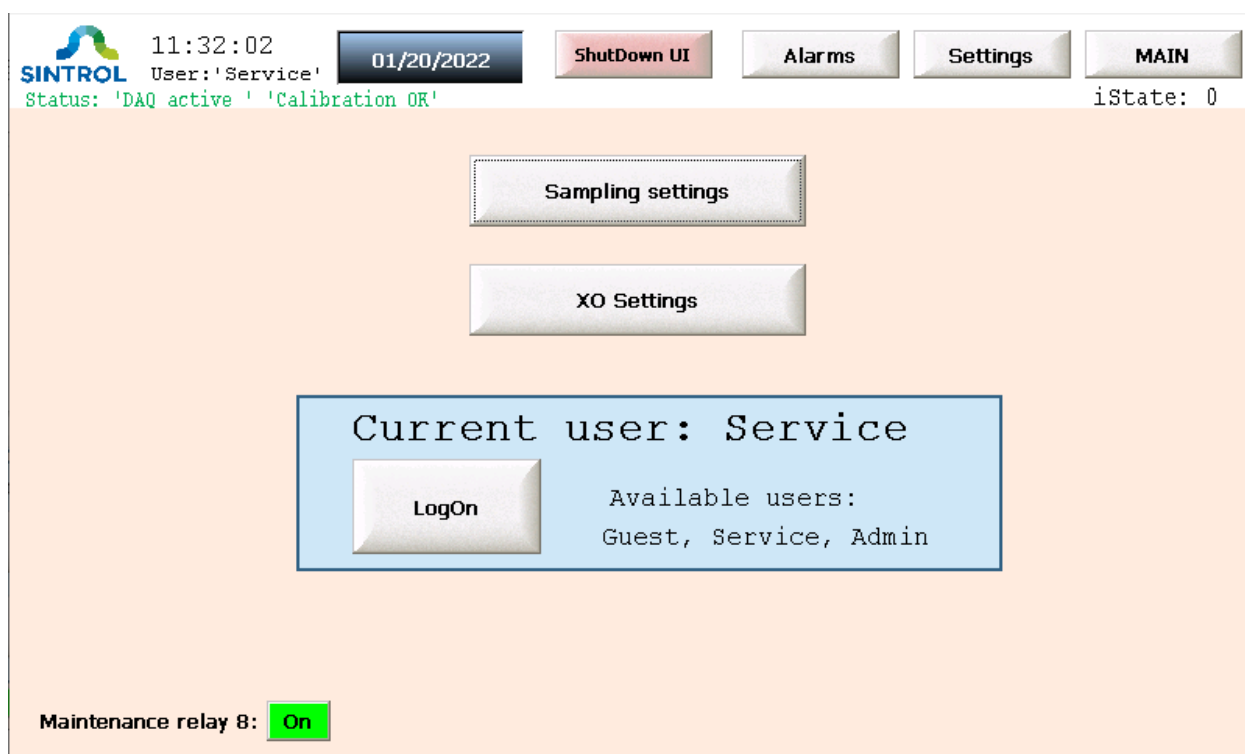

Figure 37: Settings view as Service user

When logged in as Guest user, the Settings view only contains the LogOn button. When logged in as Service or Admin user, the view also contains buttons to access the settings that affect the operation of the sampling line and optical XO sensor module.

8.5.1 User access levels

The device has three user access levels with different user rights. Settings button on the top of the MAIN view opens LogOn page where you can log in as different users. The three user access levels are:

- | | |
|----------------|--|
| Guest | Default user in normal operation. Can see the measurement views but cannot start any check functions or edit device parameters. |
| Service | Can start check functions on Settings view and edit calibration parameters. Commissioning and normal parametrization is done with Service level user rights. Default Service password is “4321”. |
| Admin | Can start all device functions, modify configuration settings and has access to all device parameters. Contact the manufacturer or an authorized distributor for the admin password. |

NOTICE

Only service personnel who are fully familiar with the device and its operation are allowed to login as Admin user. Incorrect parametrization can cause severe malfunction. Admin level settings and functions are outside the scope of this manual.

8.5.2 Logging in

When you start up the device, the default user level on the integrated PC is Guest. To log in as a different user:

1. Click the Settings button on the startup view to open the LogOn page.
2. Click the LogOn button.



3. Select the user access level on the User Name field. Either select it from the drop-down menu or press the "+" button until the correct username appears.
 - For Service and Admin user, click the Password field and insert the correct password user using the numpad that appears. When you are done, click OK.
 - For Guest user, no password is needed.

8.5.3 Sampling settings

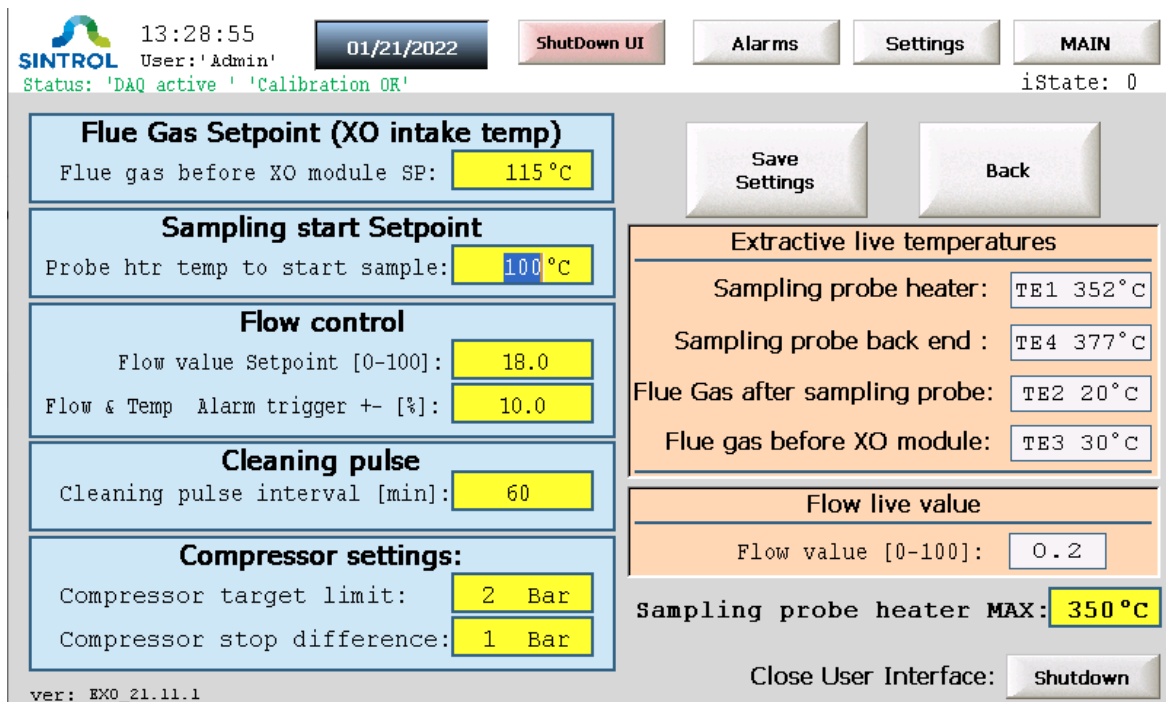

13:28:55
User: 'Admin'
Status: 'DAQ active' 'Calibration OK'

01/21/2022

ShutDown UI

Alarms

Settings

MAIN

iState: 0

Flue Gas Setpoint (XO intake temp)
Flue gas before XO module SP: 115 °C

Sampling start Setpoint
Probe htr temp to start sample: 100 °C

Flow control
Flow value Setpoint [0-100]: 18.0
Flow & Temp Alarm trigger +- [%]: 10.0

Cleaning pulse
Cleaning pulse interval [min]: 60

Compressor settings:
Compressor target limit: 2 Bar
Compressor stop difference: 1 Bar

Save Settings

Back

Extractive live temperatures

Sampling probe heater: TE1 352 °C

Sampling probe back end : TE4 377 °C

Flue Gas after sampling probe: TE2 20 °C

Flue gas before XO module: TE3 30 °C

Flow live value
Flow value [0-100]: 0.2

Sampling probe heater MAX: 350 °C

Close User Interface: Shutdown

ver: EXO_21.11.1

Figure 38: Sampling settings

Sampling settings view contains various parameters related to sampling, cleaning pulse and sampling flow measurement. It also displays live temperatures for different components of the sampling line.

See section **Parameters and settings** in this chapter for information about the parameters that you can edit in this view.

8.5.4 XO Settings

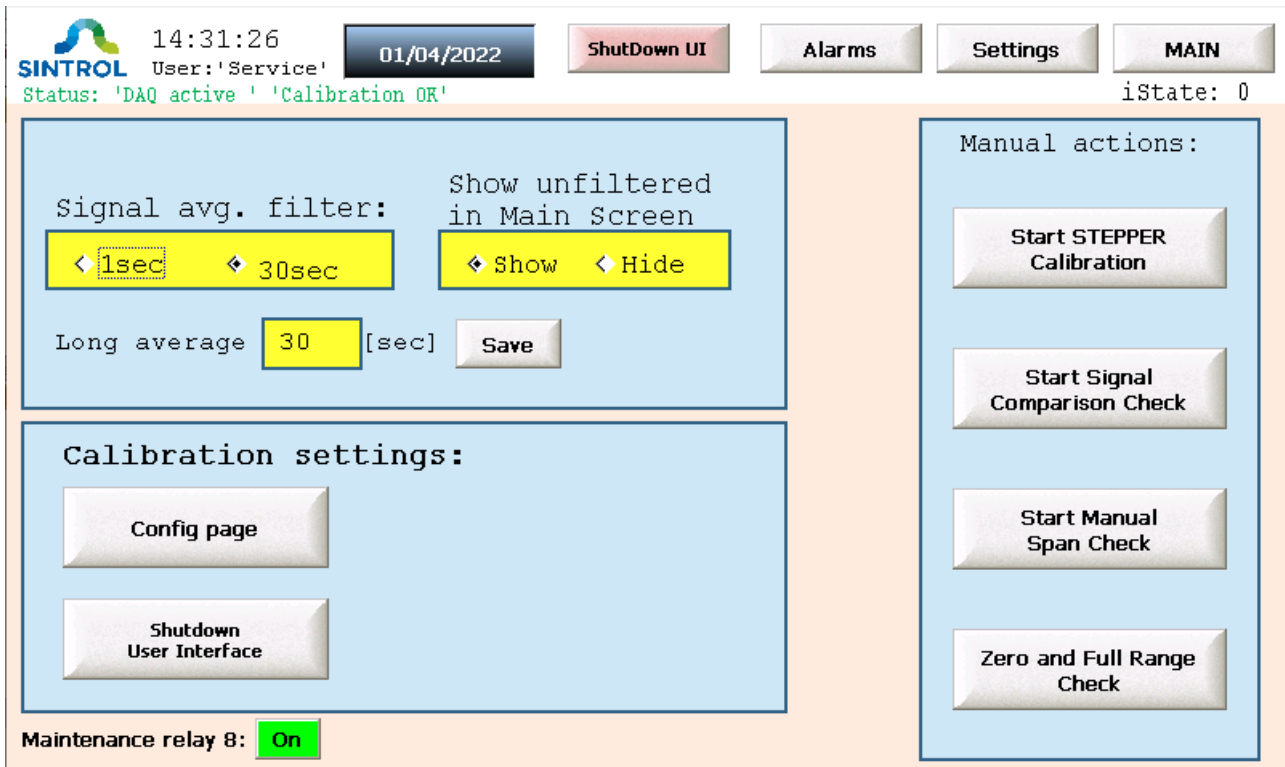

Figure 39: XO Settings view

You can change the signal averaging filter settings on the XO Settings page. Changing “Signal avg. filter” settings changes the way the graphic display in Optical view shows the current dust level. You can also adjust the value of the long averaging time.

You can access device calibration settings through XO Settings view. Additionally, the right side of the screen has buttons to manually initiate certain checks and device functions.

See section **Device functions** in chapter **Operation** for instructions on initiating the device functions. The functions are described in detail in section **Optical XO sensor module** in chapter **Functional description of sampling line**.

8.5.5 Config Page

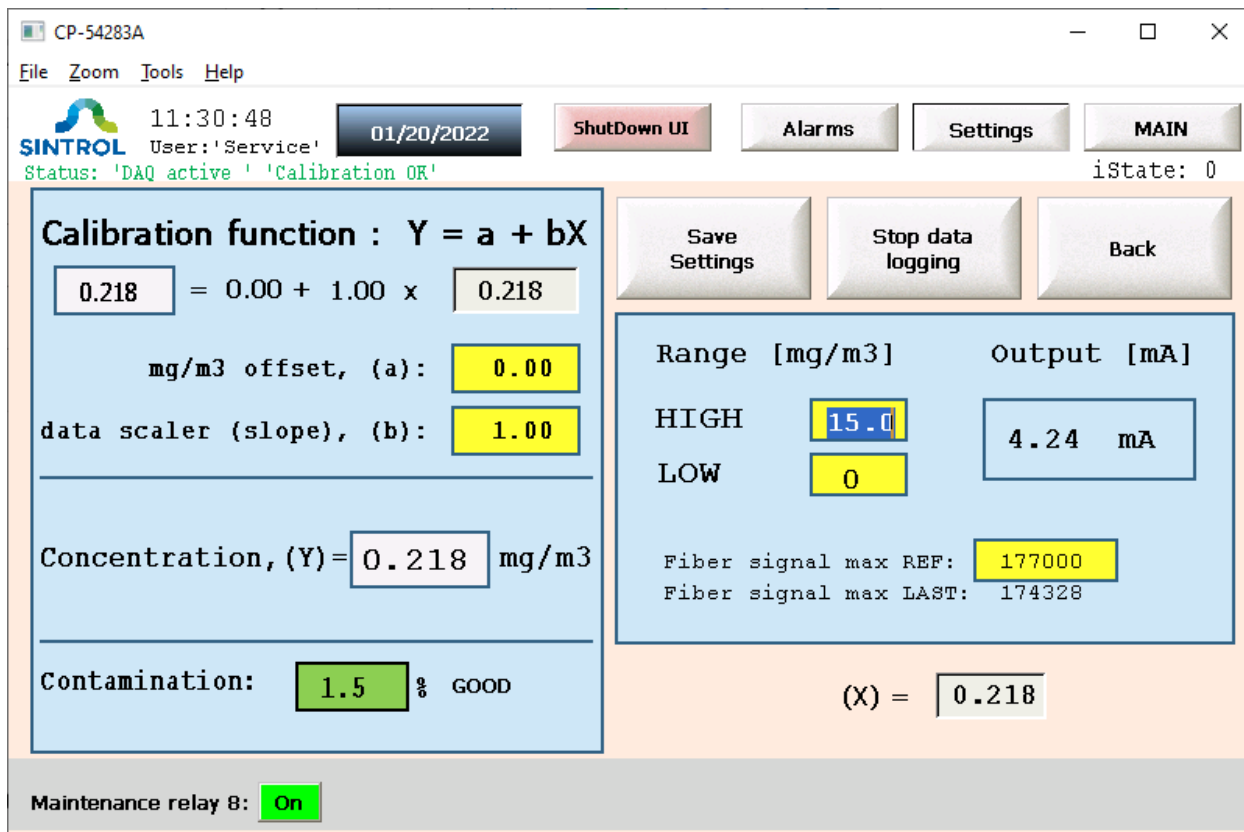

CP-54283A

File Zoom Tools Help

11:30:48 01/20/2022 User: 'Service' Status: 'DAQ active' 'Calibration OK' iState: 0

ShutDown UI Alarms Settings MAIN

Save Settings Stop data logging Back

Calibration function : $Y = a + bX$

0.218 = 0.00 + 1.00 x 0.218

mg/m3 offset, (a): 0.00

data scaler (slope), (b): 1.00

Concentration, (Y) = 0.218 mg/m3

Contamination: 1.5 % GOOD

Range [mg/m3] Output [mA]

HIGH 15.0 4.24 mA

LOW 0

Fiber signal max REF: 177000

Fiber signal max LAST: 174328

(X) = 0.218

Maintenance relay 8: On

Figure 40: Configuration page

On the Config Page you can perform device calibration, set the HIGH and LOW values for mA output scaling, and enable or disable data logging. Additionally, the page shows the contamination level of the optical components of the sensor module.

Config Page contains a contamination indicator that displays the contamination level as a percentage. When the contamination is at an acceptable level, the background of the percentage value is green and the text next to the value reads “GOOD”. This means that contamination does not affect the measurement results.

If the device startup is not successful, the light source is faulty or the contamination level is too high, the background of the percentage values is blinking red and the text next to the value reads “Check Instrument”.

9 Commissioning and system setup

After the device is installed and all the necessary electrical connections are made, the device is ready to be commissioned. Commissioning consists of the following steps:

1. Powering on the device and setting up the user interface. If you do not use the local touchscreen display, install and set up Remote Display Control software (CRHOST).
2. Logging in as Service user.
3. Having an accredited testing facility calibrate the device for the operating conditions of the process that the device monitors.

The device is ready for normal operation after you have completed these steps.

9.1 Setting up user interface

You can control the device either locally using the touchscreen on the integrated panel PC or with CERHOST. See Figure 41 for the startup view of the operation software.



Figure 41: Startup view of the user interface

For a detailed overview of the user interface, see chapter **User interface**.

9.1.1 Local touchscreen display

The local panel PC is operational after connecting power to the device. You can navigate the menus by tapping on the screen.

9.1.2 Using Remote Display Control software (CERHOST)

You can use an external laptop or desktop computer to access the user interface by connecting to the device with CerHost.exe remote display software. CerHost.exe is a freeware software that is included on a USB drive with standard delivery. You can also request the executable from the manufacturer or an authorized distributor, or download it online for free.

You can use CERHOST either by connecting an external computer directly to the integrated panel PC with Ethernet cable, or by connecting the panel PC to a wireless router.

To connect the device to an external computer using Ethernet cable:

1. Save CerHost.exe to an appropriate location on your computer.



2. Connect the Ethernet port of the integrated panel PC to the Ethernet port of the external computer with Ethernet cable.
3. Launch CerHost.exe. The software does not require installation. Simply double-click the icon or right-click and select Run.
4. Navigate to File menu and select Connect.

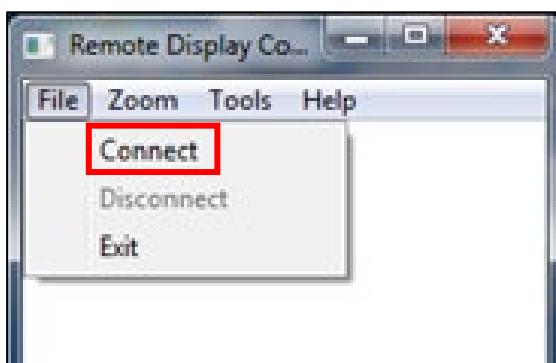

5. Insert the IP address of the integrated panel PC to Hostname field.

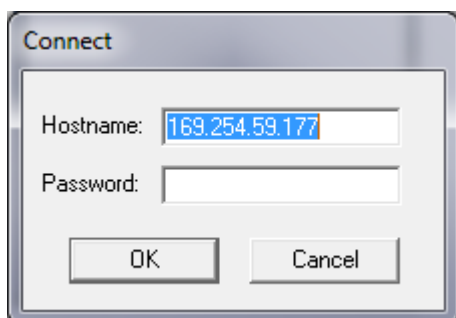

- Correct IP address is printed on the side of the integrated panel PC.
- No password required.

6. The user interface appears on the screen of the external computer.



If the computer displays an error message “Can’t connect”, make sure that the computer’s firewall is not preventing the connection. You can disable the firewall momentarily to allow the connection and enable it once the remote connection is established.

9.2 Logging in as Service level user

When you start up the device, the default user level on the integrated PC is Guest. To change the device settings and edit parameters values, you must log in as Service user:

1. Click the Settings button on the startup view to open the LogOn page.



2. Click the LogOn button.



3. Select Service on the User Name field. Either select it from the drop-down menu, or press the “+” button until the correct user name appears.

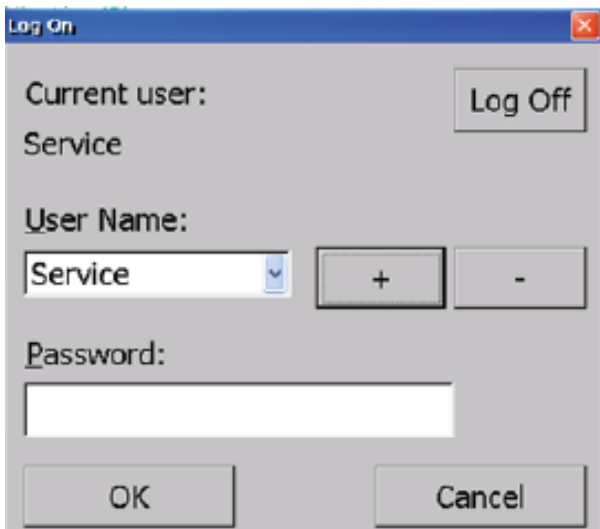

4. Click the Password field and insert the default password “4321” for the Service level user using the numpad that appears. When you are done, click OK.
5. You are now logged in as Service user, and Settings button appears in the middle of the screen.

For detailed overview of user access levels and user rights, see section **User access levels** in chapter **User interface**.

9.3 Calibration

Each installed device must be calibrated to the process conditions at the installation site. Calibration is typically performed a few weeks after installation, and it requires the calibration parameters to be adjusted according to the results of a measurement done using standard reference method (SRM), for example gravimetric sampling. An accredited testing facility performs the reference measurement.

The calibration utilizes a linear regression curve with an equation $y_i = \alpha + \beta x_i$, where values α and β determine the offset and scale of the regression curve. These values are calculated based on the results of a reference measurement.

See section **Calibration parameters** in chapter **Operation** for details about setting the calibration parameters.

10 Operation

10.1 Main power switch

Main power switch is located on the inside of the enclosure door that houses the integrated panel PC. The switch has two positions: ON and OFF.

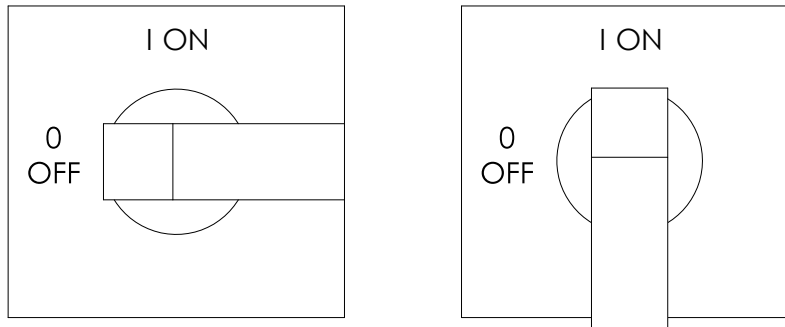

Figure 42: Main power switch in OFF and ON position

10.1.1 Powering up

To power up the device:

1. Make sure the power supply socket is plugged in.
2. Turn the main power switch to ON position.

10.1.2 Powering down

To power down the device:

1. If sampling is active, navigate to Sampling view and click the Stop button to stop sampling.
2. Turn the main power switch to OFF position.

10.2 Starting and stopping sampling

To start sampling:

1. Navigate to Sampling view.
2. Click the Start button.

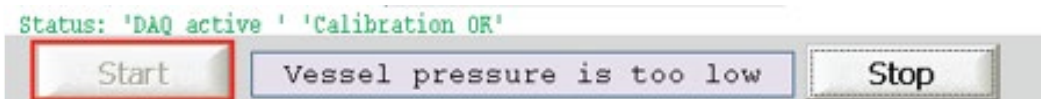

To stop sampling:

1. Navigate to Sampling view.
2. Click the Stop button.

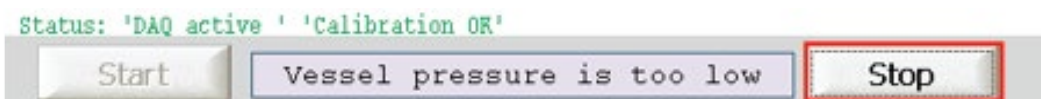

10.3 Device functions

The device has certain key functions that ensure its safe and reliable operation. Most of the functions are performed automatically by a set interval, but you can initiate them manually from the user interface for troubleshooting.

The functions can be accessed in the XO Settings page on the Settings view.



You must be logged in as Service or Admin user to run any of the functions described in this section.

10.3.1 Automatic stepper calibration

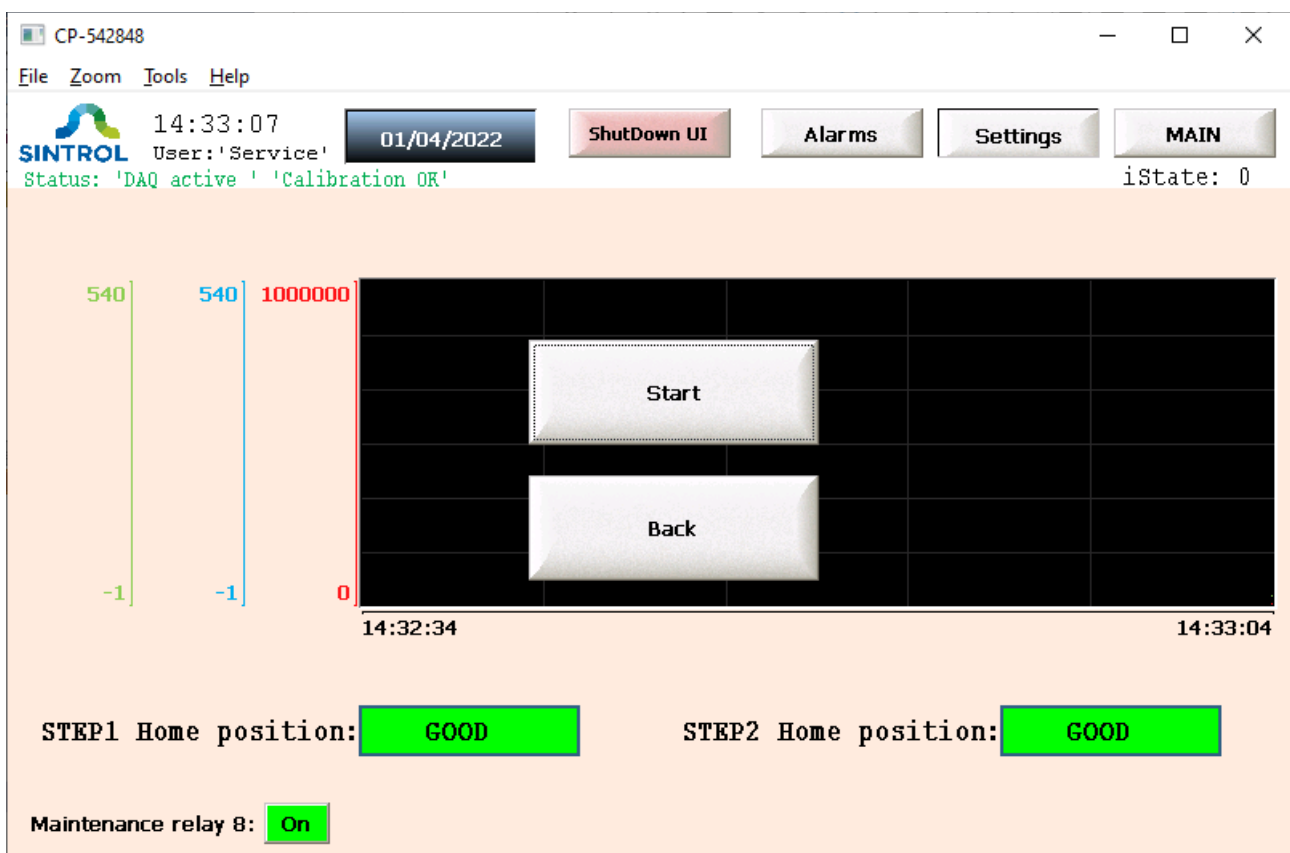

Figure 43: Stepper Calibration view

There are two stepper motors inside the optical XO sensor modules. The motors are used to block the light from the light source or guide it to a different path depending on the device function that is running. To ensure that they are positioned correctly, you must calibrate them.

To start stepper calibration:

1. Navigate to XO Settings view and click the Start Stepper Calibration button.
2. Stepper calibration view opens. Click the Start button.

3. While the stepper motor calibration is active, the upper part of the window displays the text “Stepper calibration active, wait...”.
4. After the stepper calibration is finished, the status is indicated on the lower part of the screen.
 - GOOD on green background indicates a successful calibration.
 - NOT FOUND on red background indicates that the calibration failed.

Stepper motors are very reliable and rarely fail in normal use. However, if the calibration fails, perform the calibration again. You can also try restarting the device. If neither solves the problem, check stepper motor wirings.



If you are unable to solve the problems related to stepper calibration, contact the manufacturer or an authorized distributor.

10.3.2 Zero and full range check

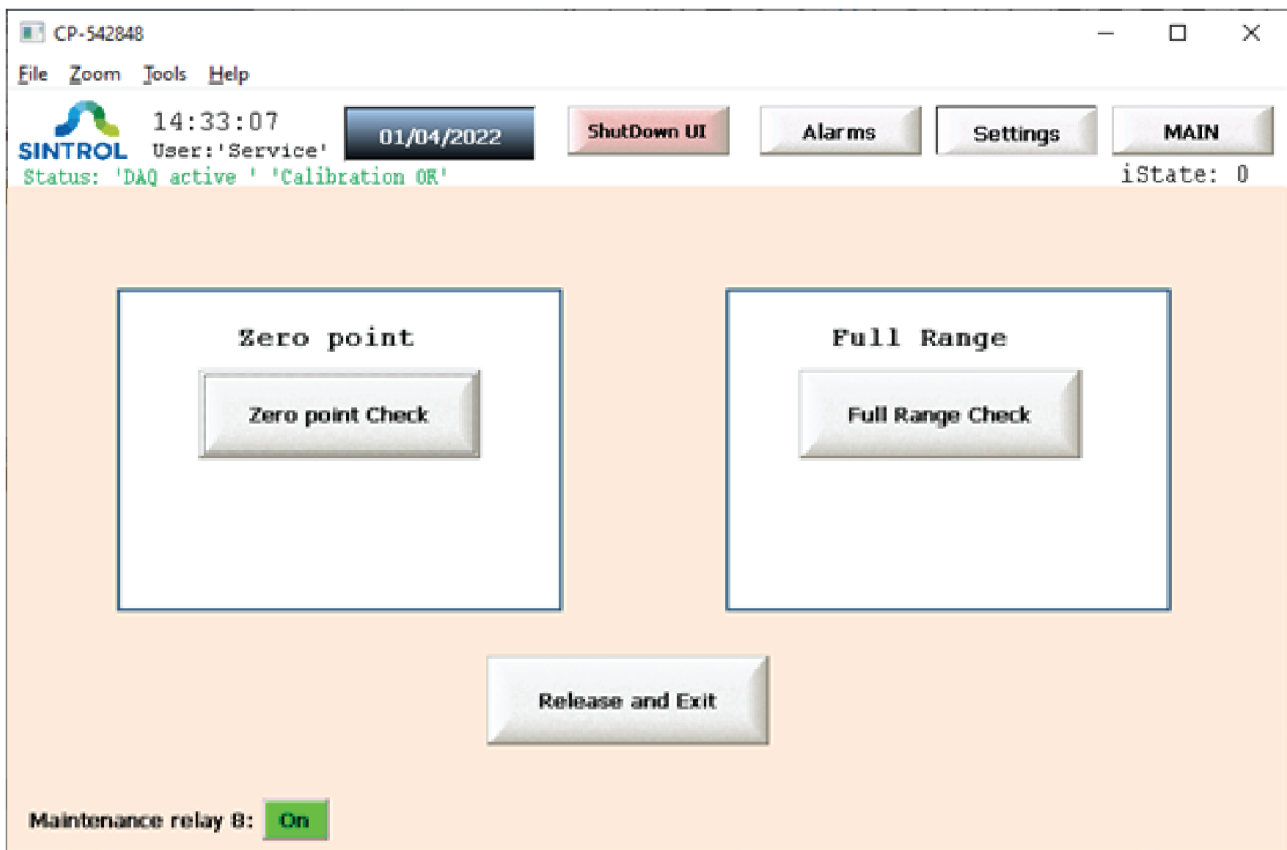

Figure 44: Zero and full range check view

You can perform the zero and full range check to see if the mA output of the device is still within the 4 ... 20 mA range. This way you can identify if there is any drift in the mA output.

To check zero point and full range values:

1. Navigate to XO Settings page and click the Zero And Full Range button.

2. Click the Zero Point Check button. The box displays a value close to 4 mA and a corresponding mg/m³ value.



3. Click the Release button.
4. Click the Full Range Check button. The box displays a value close to 20 mA and a corresponding mg/m³ value.



5. Click the Release button.
6. After you have confirmed that the values match the calibrated LOW and HIGH values, click the Release And Exit button to return to XO Settings.

10.3.3 Signal comparison check

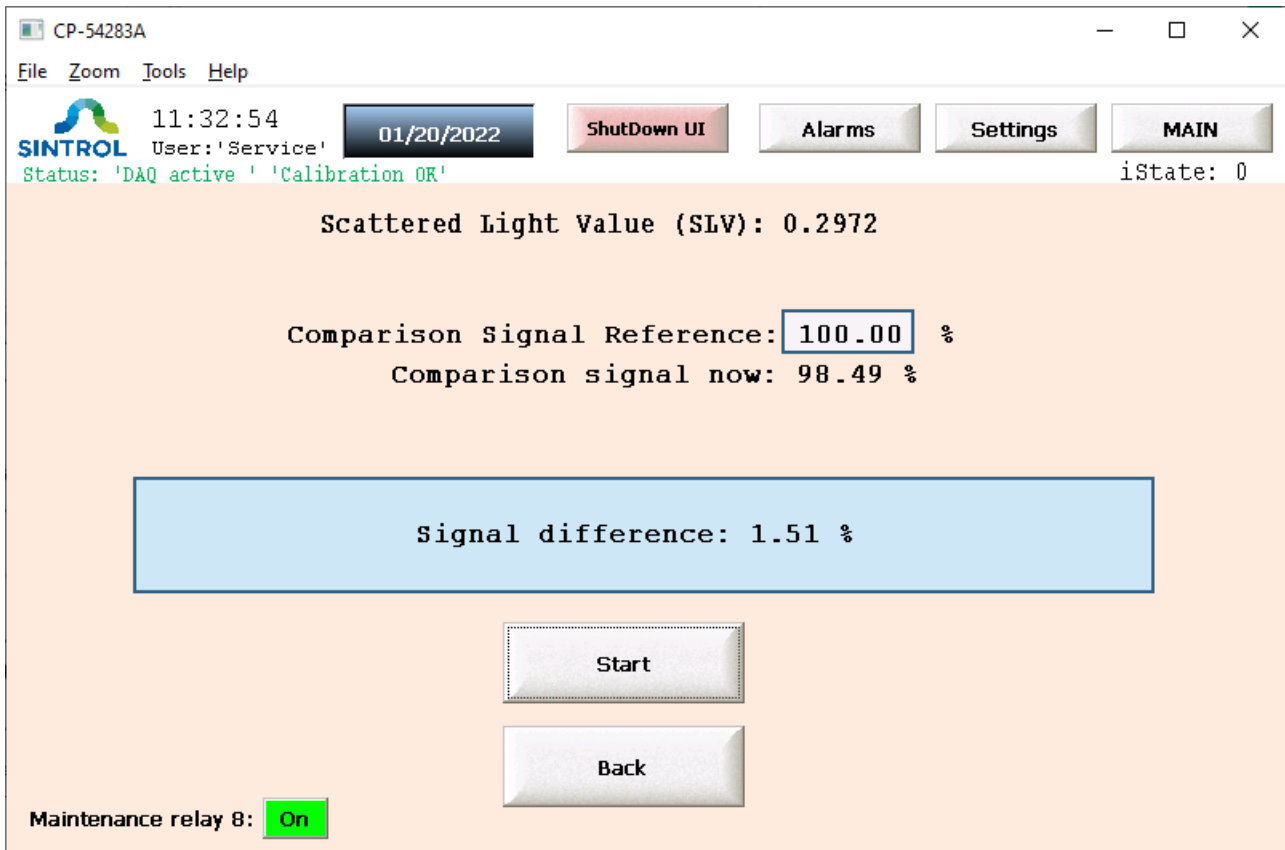

Figure 45: Signal comparison check view

You can perform a signal comparison check to identify any changes in the measurement response that the ageing of the light source and photodiode receiver in the scattered light detector can cause. The comparison check also enables the device to adjust the light source and receiver to compensate any possible influence that temperature changes can have on the measurement results.

To start signal comparison check:

1. Navigate to XO Settings page and click the Start Signal Comparison Check button.
2. Signal Comparison view opens. Click the Start button.
3. After the signal comparison check is done, the view displays the difference between the reference signal and current signal.

10.3.4 Manual span check



There must be no particle stream in the measurement chamber during span check. This procedure describes the manual span check for situation when there would be dust particles in the sample gas.

If you are absolutely sure that there are no particles in the sample, you can perform manual span check during normal operation. In that case, simply insert the span check audit unit into the optical XO sensor module as instructed in step 6 in the following section and read the measurement value from the user interface.

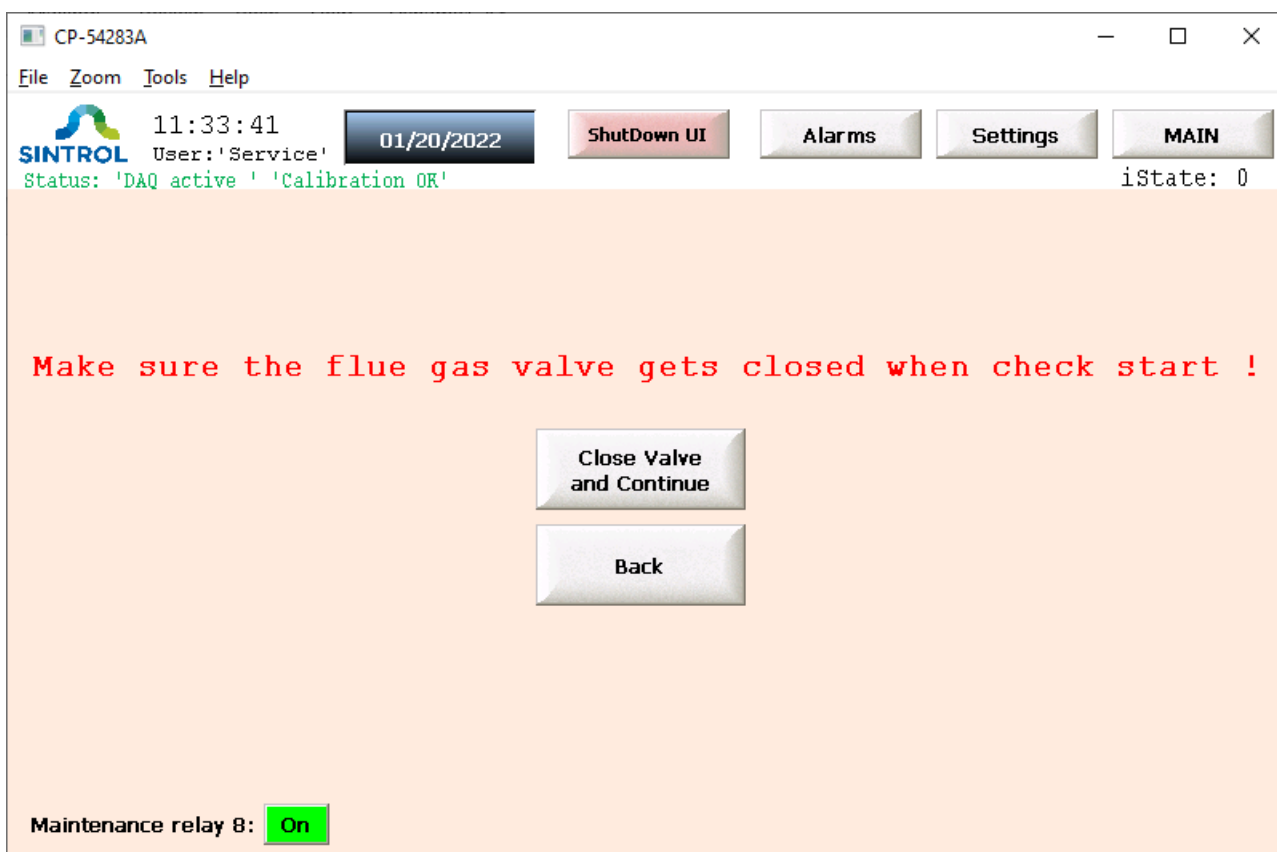

Figure 46: Start Span Check view

Manual span check can be used to test the linearity of the measurement response of the optical XO sensor module, for example when required by annual surveillance test (AST).

To perform manual span check, you need:

- Span check audit unit

You can order the span check audit unit from the manufacturer or an authorized distributor.

To start manual span check:

1. Navigate to XO Settings page and click the Start Manual Span Check button.
2. Open the device enclosure doors so you have access to the optical XO sensor module. Make sure that the flue gas valve is closed.

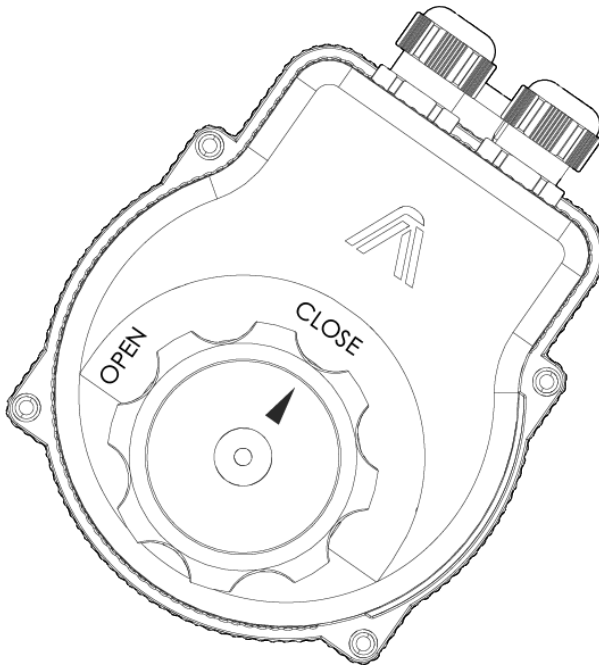

3. The software prompts you to make sure that the flue gas valve is closed. If the indicator on the side of the flue gas valve is in CLOSE position, click the Continue button.

Make sure the fluegas valve is closed before continue!



4. The software generates a reference signal and counts down from 30 seconds.

Time remaining : 21 sec

REFERENCE SIGNAL - Measure active, wait..

5. After the counter reaches 0, the software prompts you to install the span check audit unit to the sensor module before continuing.

Install SPAN FILTER before continue!



6. Remove the empty span check audit unit holder from the slot on the bottom of the optical XO sensor module.
7. Insert a span check audit unit into the slot on the bottom of the optical XO sensor module.

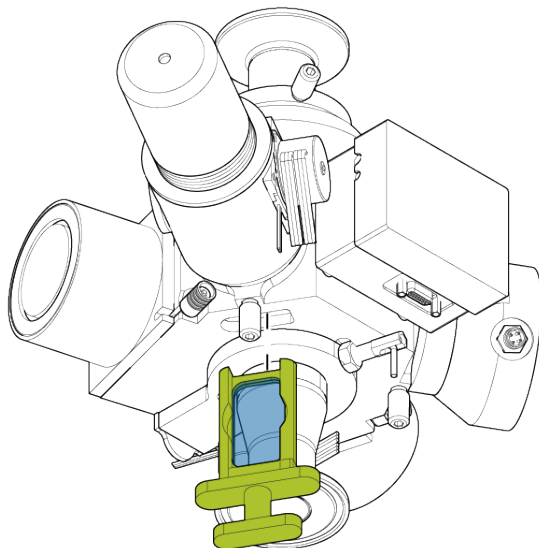

8. Click the Continue button.
9. The screen displays the remaining time in seconds until the span check is complete.

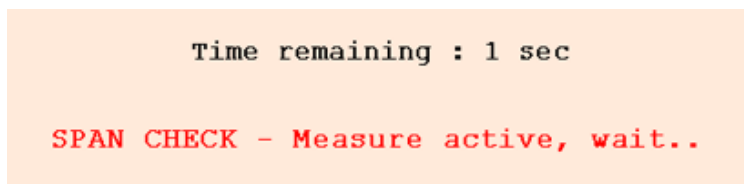

10. After the device has performed the span check, the screen displays the measurement values, and prompts you to remove the filter.

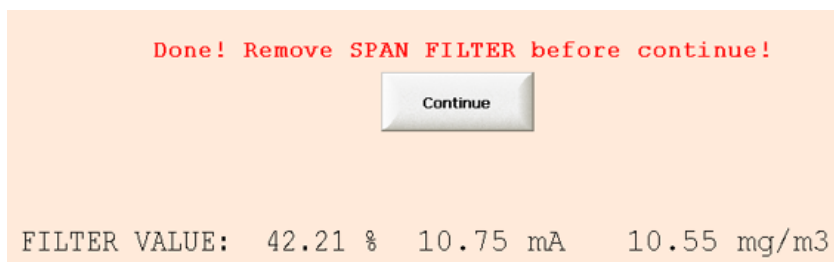

11. Remove the span check audit unit from the sensor module and insert the empty holder back into the slot on the bottom of the sensor module.
12. Click the Continue button. Manual span check is now completed.

10.4 Restarting user interface

Sometimes it is necessary to shut down the user interface and reset the device, for example during troubleshooting and periodic maintenance. You can shut down the user interface on the MAIN view, Sampling Settings and XO Settings pages.

1. Navigate to MAIN view, Sampling Settings or XO Settings page and press the Shutdown button.

- Main view, in the upper left corner



- Sampling settings, on the lower right corner



- XO Settings, on the lower left corner

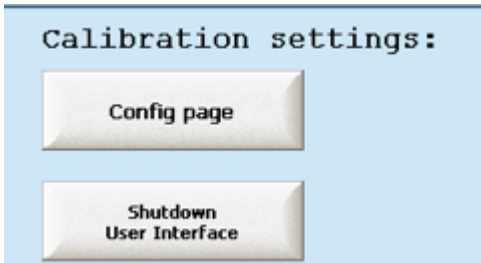

2. The user interface shuts down, and the panel PC displays Sintrol logo. Open the Start menu and select Reset.



3. After resetting the control PC, the user interface restarts and performs the initial procedures, including stepper calibration.

4. If necessary, reconnect to Cerhost.exe. See section **Setting up user interface** in chapter **Commissioning and system setup** for instructions.

10.5 Parameters and settings



User-editable parameter values have yellow background on the user interface.



When editing parameter values, always click the Save Settings button after you are done. Otherwise the device reverts to previously saved values if it is powered down or if the user interface is restarted.

10.5.1 Continue sampling after power failure

The setting to continue sampling after power failure is located in Sampling view.

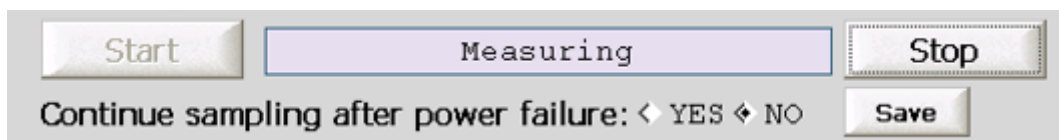

Figure 47: Continue sampling after power failure setting

This setting determines how the device acts in the event of power failure. If the setting is enabled, the device resumes sampling automatically after the power is restored. The device continues data logging if it was enabled when the power failure occurred.

10.5.2 Flue gas setpoint

Flue gas setpoint parameter is located on Sampling Settings view.

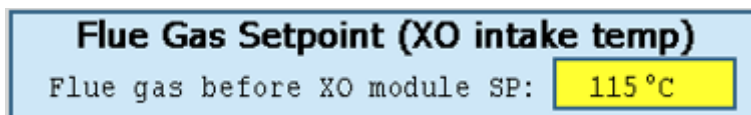

Figure 48: Flue gas setpoint parameter

This parameter sets the target temperature for the sample gas before it enters the optical XO sensor module. Parameter value is set in Celsius.

10.5.3 Sampling start setpoint

Sampling start setpoint parameter is located on Sampling Settings view.

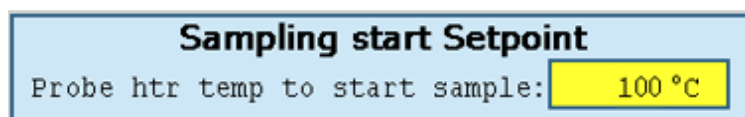

Figure 49: Sampling start setpoint

This parameter sets the target flue gas temperature before the sampling starts. If the flue gas temperature is below this value, the flue gas valve stays in OFF position and the device does not start the sampling procedure. Parameter value is set in Celsius.

10.5.4 Flow control

Flow control

Flow value Setpoint [0-100]:

Flow & Temp Alarm trigger +- [%]:

Figure 50: Flow control parameters

The device continuously measures the flow rate of the sample gas at the sensor probe nozzle before the gas enters the sampling line and the optical XO sensor module. You can adjust the flow value setpoint and the alarm threshold for sample gas flow and XO intake temperature.

Table 6: Flow control parameters

Parameter	Description	Unit
Flow value setpoint	Parameter sets the reference value for the sample gas flow velocity at the nozzle of the sampling probe. When the sampling flow measurement is within the reference value, the flow velocity at the probe nozzle matches the flow velocity inside the stack.	Reference value (0–100)
Flow & temp alarm trigger +-	Sets the permitted deviation in the flow value setpoint and flue gas temperature setpoint. When flow or temperature measurement is outside this range, the device activates the corresponding digital output to indicate a problem with sampling.	%

10.5.5 Cleaning pulse interval

Cleaning pulse interval parameter is located on Sampling Settings view.

Cleaning pulse

Cleaning pulse interval [min]:

Figure 51: Cleaning pulse interval

The device performs a periodical self-clean function where a pressurized air pulse is directed through the sampling probe. During the cleaning pulse, the device closes the flue gas valve and opens the cleaning pulse valve. This allows the air pulse to travel from the pressure vessel to the probe without entering the optical XO sensor probe.

Parameter value is set in minutes.

10.5.6 Compressor settings

Compressor settings are located on Sampling Settings view.

Compressor settings:

Compressor target limit:

Compressor stop difference:

Figure 52: Compressor settings parameters

The device is equipped with an internal compressor and pressure vessel to create the pressurized air required for the cleaning pulse. You can change the compressor setting to set a maximum pressure in the pressure vessel.

Table 7: Compressor settings

Parameter	Description	Unit
Compressor target limit	Sets the target pressure in the pressure vessel when the cleaning pulse procedure is active.	Bar
Compressor stop difference	Sets a buffer value for the maximum pressure. This value defines how much the pressure inside the pressure vessel can exceed the target limit before the compressor stops compressing.	Bar

For example, if Compressor target limit is 5 Bar and Compressor stop diff. is 1 Bar, the compressor increases the pressure up to 6 Bar and stops compressing. The compressor does not start again until the pressure drops below 5 Bar.

10.5.7 Maximum heater temperature

The parameter that controls the maximum temperature of the sample probe heater is located on Sampling Settings view.

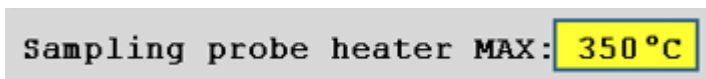

Figure 53: Maximum heater temperature parameter

The parameter sets the safety limit for heater element temperature. This prevents the heater temperature for rising indefinitely, for example if the thermocouple that monitors the sampling probe temperature fails.

Table 8: Maximum heater temperature parameter

Parameter	Description	Max. value	Unit
Sampling probe heater MAX	Sets the maximum temperature for the sampling probe heater element.	500	Celsius

10.5.8 Averaging time

Averaging time settings are located on XO Settings view.

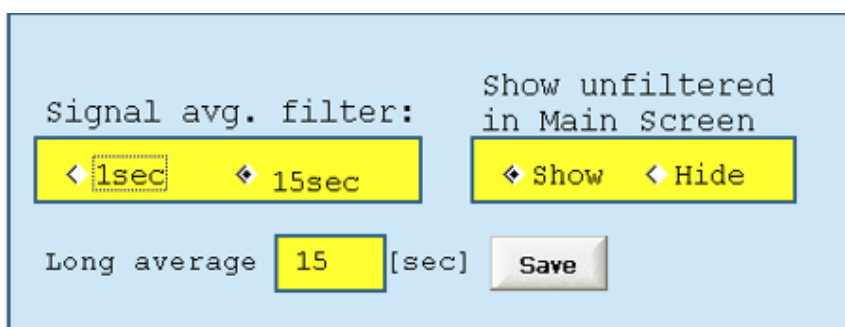

Figure 54: Averaging time parameters

Averaging time determines the period from which the device calculates the average dust level from. The graphic display on Optical view can be configured to use either a short averaging time of 1 second, or the user-adjustable long averaging time. Analog mA output always uses the long averaging time.

Table 9: Averaging time parameters

Parameter	Description	Unit
Signal avg. filter	Selects the averaging time for the graphic display on Optical view.	n/a
Long average	Sets the averaging time for the long averaging time of the Signal avg. filter setting.	Seconds



Maximum value for the “Long average” parameter is 3600 seconds (1 hour).

10.5.9 Calibration parameters

Calibration parameters are located on Config Page. You can access Config Page through XO Settings view.

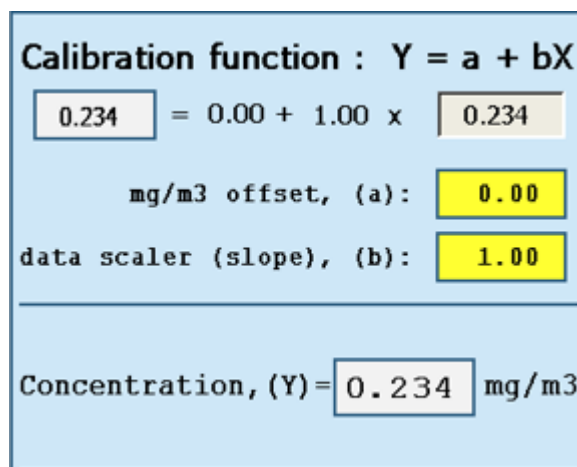

Figure 55: Calibration parameters

To calibrate the device, edit the values of “Data scaler (slope)” and “mg/m3 offset” parameters. See Table 10 for details.

Table 10: Calibration parameters

Parameter	Description	Default value
Data scaler	Sets the slope β of the linear regression curve used for calibration.	1.00
mg/m3 offset	Sets the offset α of the linear regression curve used for calibration.	0.000

The calibration utilizes a linear regression curve with an equation $y_i = \alpha + \beta x_i$, where values α and β determine the offset and scale of the regression curve. These values are calculated based on the results of a reference measurement performed by an accredited testing facility.

To calibrate the device:

1. Navigate to XO Settings and click the Config Page button in the “Calibration settings” section.
2. Input value β to parameter “Data scaler (slope)”

data scaler (slope), (b): 1.00

3. Input value α to parameter “mg/m3 offset”

mg/m3 offset, (a): 0.00

4. Save the values by clicking the Save Settings button.
5. After changing the calibration parameters, alarm relay 7 indicates an alarm.
6. Run a reference check and signal comparison check to turn off the alarm relay.

See section **Device functions** in this chapter for instructions on initiating device self-checks.

See section **Calibration** in this chapter for more information about the prerequisites for calibration.

10.5.10 mA output signal scaling

mA output signal scaling parameters are located on Config Page. You can access Config Page through XO Settings view.

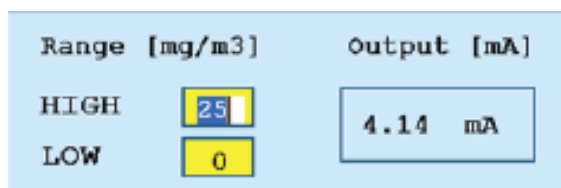

Figure 56: mA output signal scaling parameters

You can change these parameters to adjust the dust concentrations that correspond to the minimum and maximum mA signal levels.

Table 11: mA output signal scaling parameters

Parameter	Description	Unit
HIGH	Sets the dust concentration in mg/m ³ that corresponds to 20 mA output signal.	mg/m ³
LOW	Sets the dust concentration in mg/m ³ that corresponds to 4 mA output signal. Typically set to zero.	mg/m ³

10.5.11 Fiber signal max REF

You can adjust the fiber signal reference value on Config Page. You can access Config Page through XO Settings view.

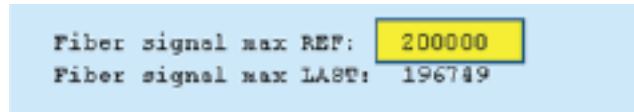

Figure 57: Fiber signal max REF values

This parameter value is used as a reference when the device performs the signal comparison check. During signal comparison check, the device bypasses the normal light beam path, and instead directs the light directly to the scattered light detector through optical fiber.

Table 12: Fiber signal max REF values

Parameter	Description	Unit
Fiber signal max REF	Sets the reference value that the device compares the results of signal comparison check to.	SLV
Fiber signal max LAST	Shows the results of the previous signal comparison check.	SLV

10.6 Data logging

The device has a data logging feature that saves measurement data, self-check results, parameters, and possible warning messages onto a log file. This data can be used to view the history of measurement values and device statuses to help troubleshoot problems.

When the data logging is enabled, the device saves the log file on a USB flash drive that is connected to the USB port of the integrated panel PC.

For the data logging to work, the connected USB drive must:

- be formatted to FAT32 file system
- contain a folder named “data”

The log file is a CSV file that can be opened in a third-party software, for example Microsoft Excel. The CSV files are stored in the data folder on the USB drive. File name is the date the file was generated, for example “2020-03-13.csv”.



The data logging feature is designed only to help in troubleshooting, and it is not meant to replace a dedicated automation monitoring and logging system. Using it does not fulfill the requirements of standards related to emission control and monitoring.

10.6.1 Enabling data logging

You can enable data logging on the Config Page when you are logged in as Service or Admin user. Simply click Start Data Logging button, and the device will start saving log files on the connected USB flash drive:

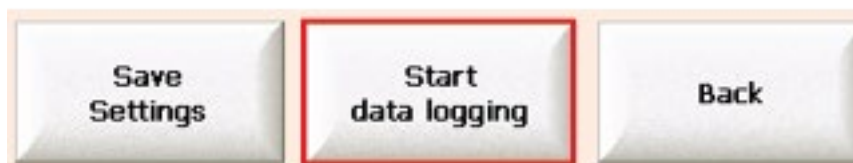

Figure 58: Start data logging

When the data logging is enabled, you can use the same button to stop data logging.



Figure 59: Stop data logging

The device continues to save log files onto the USB drive as long as the device remains powered on. However, if you shut down the user interface or restart the integrated control PC, you must resume data logging manually each time.

11 Troubleshooting

If performing the checks as instructed in this section does not solve your problem, contact the manufacturer or an authorized distributor.

11.1 Error messages

When the device detects an error, it engages either alarm relay 6 or 7 and displays an error message on the Alarms view.

Table 13: Description of error messages

Error	Description	Solution
ZERO&REF check error!	Reference check outside factory-set reference values.	Inspect the optical components.
Stepper1 homing error!	Stepper motor 1 is unable to return to home position.	Perform Stepper Calibration.
Stepper2 homing error!	Stepper motor 2 is unable to return to home position.	Perform Stepper Calibration.
CSV-File writing error! Check that there is “data” folder on the USB stick	The device cannot detect “data” folder on the USB drive.	Make sure that the USB drive is connected and that it is formatted properly.
Light source or optical fiber failure! Check instrument!	Automatic self-check failure. Results exceed factory-set reference value more than 30%.	Check that the optical fiber cable is connected and not damaged.
Check comparison signal!	Manual comparison check failure. Results exceed factory-set reference value more than 30%.	Check the condition of light source unit.

11.1.1 ZERO&REF check error

ZERO&REF check error indicates that the results of the reference check are outside the factory-set reference values. This indicates that there is possible dust contamination on the optical components of the XO sensor module.

- If the reference measurement exceeds the factory value more than 30%, the device displays error message “ZERO&REF check error”.
- If the reference measurement exceeds the factory value more than 60%, the device displays error message “ZERO&REF check error” and disables the analog mA output.

If the device displays the error message “ZERO&REF check error”:

- Run reference check manually to see if the error persists. See section **Zero and full range check** in chapter **Operation** for instructions.
- Inspect the optical components of the XO sensor module and clean them if necessary. See section **Optical XO sensor module** in chapter **Maintenance and inspection** for instructions.

For more information about the internal reference check, see section **Reference check** in chapter **Functional description of sampling line**.

11.1.2 Stepper1 and stepper2 homing error

The optical XO sensor module contains two stepper motors that are used to control the path of the light beam. When the stepper motors are not used, they are in their default home position. If either stepper motor is unable to return to its home position, the device displays an error.

If the device displays either error message “Stepper1 homing error” or “Stepper 2 homing error”:

- Perform Stepper Calibration. See section **Automatic stepper calibration** in chapter **Operation** for instructions.
- If running the stepper calibration does not fix the error, reset the user interface. See section **Restarting user interface** in chapter **Operation** for instructions.

For more information about the functioning of the stepper motors, see section **Optical XO sensor module** in chapter **Functional description of sampling**.

11.1.3 CSV-File writing error

When data logging is enabled, the device stores log files in the data folder of a USB drive that is connected to the integrated panel PC. If the device is unable to locate the data folder and displays error message “CSV-File writing error”:

- Make sure that there is a USB drive plugged in the USB port of the integrated panel PC.
- Make sure that the USB drive is formatted to FAT32 file system.
- Make sure that the root of the USB drive contains a folder named “data”.

For more information about data logging, see section **Data logging** in chapter **Operation**.

11.1.4 Light source or optical fiber failure

If the automatic comparison check that the device performs periodically fails, the device displays an error message “Light source or optical fiber failure”. This indicates that the reference measurement results exceed the factory-set reference value by more than 30%.

- If the reference measurement exceeds the factory value more than 30%, the device displays error message “Light source or optical fiber failure”.
- If the reference measurement exceeds the factory value more than 60%, the device displays error message “Light source or optical fiber failure” and disables the analog mA output.

In this case, inspect the optical fiber and make sure that:

- the optical fiber is connected properly
- the optical fiber is not damaged

For more information about the signal comparison check, see section **Signal comparison check** in chapter **Functional description of sampling line**.

11.1.5 Check comparison signal

If the comparison check that the user starts manually from the user interface fails, the device displays an error message “Check comparison signal”. This indicates that the reference measurement results exceed the factory-set reference value by more than 30%.

- If the reference measurement exceeds the factory value more than 30%, the device displays error message “Check comparison signal”.
- If the reference measurement exceeds the factory value more than 60%, the device displays error message “Check comparison signal” and disables the analog mA output.

For more information about the signal comparison check, see section **Signal comparison check** in chapter **Functional description of sampling line**.

11.2 Using digital outputs

The device has two 8-channel digital output terminals inside the enclosure. Each digital output channel is factory-wired to the connection box that is located above the ejector chamber air outlet. You can use the connection box to connect the digital channels to an automation control system to indicate the status of the device or maintenance relays.

If you encounter a problem with the device, you can always use the digital outputs to help troubleshoot the issue, even if you have not connected the outputs to your automation system through the connection box:

- If you have connected the digital outputs to an automation control system, the system should indicate the problem.
- If you have not connected the digital outputs to a separate control system, you can check the digital output terminals inside the device enclosure. Each output on the digital output terminal has a corresponding LED that lights up when an output is active.

The digital output terminals are located on the right-side door next to the circuit breakers.

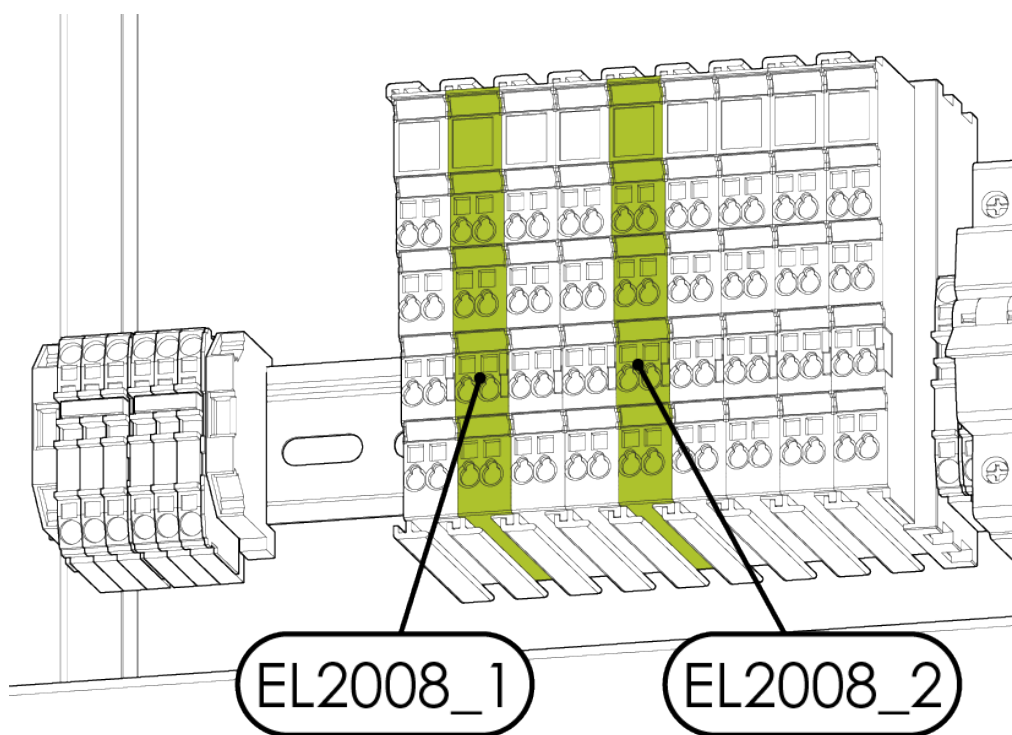

Figure 60: Digital output terminals

EL2008_1 Sampling terminal

EL2008_2 XO module terminal

The outputs on each digital output terminal are numbered 1 to 8. Each output has a corresponding LED that lights up when the output is active.

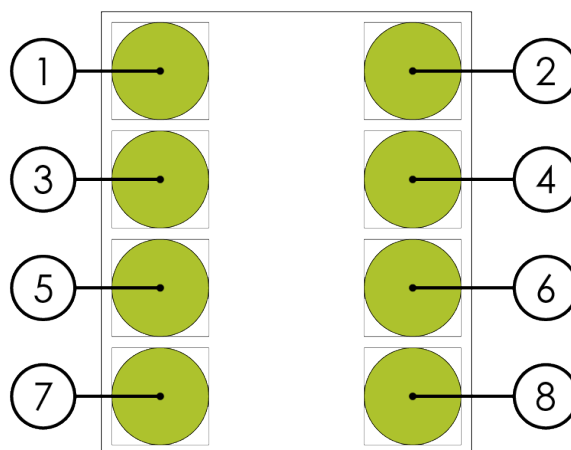

Figure 61: LED lights corresponding to the digital outputs on each digital output terminal

① LED indicator for digital output 1	⑤ LED indicator for digital output 5
② LED indicator for digital output 2	⑥ LED indicator for digital output 6
③ LED indicator for digital output 3	⑦ LED indicator for digital output 7
④ LED indicator for digital output 4	⑧ LED indicator for digital output 8



Outputs 1 to 8 of the sampling terminal (left side terminal) are connected to outputs 1 to 8 on the connection box. Outputs 1 to 8 of the XO module terminal (right side terminal) are connected to outputs 9 to 16 of the connection box.

Refer to Table 14 for conditions that activate each output. The output numbers in brackets indicate the corresponding output terminals on the connection box.

Table 14: Description output channels in the digital output terminals

Output	Sampling terminal (left)	Output	XO module terminal (right)
1	Active when the heater element of the sampling probe is ON.	1 (9)	Active when data logging is ON.
2	Active when “Continue sampling after power failure” setting is enabled.	2 (10)	Active when automatic zero point check is active.
3	Active when the deviation in flow rate is outside the permitted range in relation to the flow value setpoint.	3 (11)	Active when the manual span check is in progress.
4	Active when the XO intake temperature is outside the permitted range.	4 (12)	Active when either stepper motor is unable to return to its home position.
5	Active when the device performs a cleaning cycle.	5 (13)	Active when the device performs periodic self-diagnostics.
6	Active when the flue gas valve is closed and the sampling is not active.	6 (14)	Active when there is a fault related to the operation of the stepper motors.
7	Active when the compressor is ON and pressurizes the pressure vessel.	7 (15)	Active when there is a fault related to the optical components of the sensor module
8	Active when the purge air flow is interrupted.	8 (16)	Active when maintenance relay 8 is ON. The maintenance relay activates when the device performs periodic self-diagnostics, during the cleaning pulse and when logged in as Admin or Service user.

See section **Analog and digital outputs** in chapter **Electrical installation** for more information about connecting the digital outputs.

11.3 No output signal

- Make sure that normal processes are running and that the flue gas valve is open.
- Make sure that the device is connected to the power supply and that signal wires are connected properly.
- Dirty lenses and surfaces in the sensor module can affect the measurement results.
 - Make sure that there is no condensation in the particle stream that enters the measurement chamber.
 - Droplets and wet, sticky dust can cover the optics, and eventually damage them.

11.4 Invalid output signal

Disruptions in the normal operation of the device can cause the output signal to be abnormally high or low. The output signal can be permanently zero or it can otherwise behave in a way that does not seem to correspond to the actual process conditions.

In case of abnormal signal behavior:

- Perform signal comparison check and see if the results match the reference value. The difference must not be greater than $\pm 10\%$.
- Navigate to Settings page and start Stepper Calibration function. See section **Automatic stepper calibration** in chapter **Operation** for instructions.
 - Indicator for each stepper motor should read GOOD with green background.
 - If either stepper motor does not line properly, the corresponding indicator reads NOT FOUND with red background.

If Stepper Calibration does not restore the device to its normal operation, you can shut down the whole user interface and reset the measurement control PC. See section **Restarting user interface** in chapter **Operation** for instructions.

12 Maintenance and inspection

12.1 Safety precautions



Read chapter “Safety” carefully before performing maintenance on the device.

The device must not be modified or repaired in any way that is not specifically described in this manual. Do not perform any mechanical or electrical repairs without contacting the manufacturer or an authorized service center or distributor.

Only original Sintrol parts can be used for repairs. If third-party spare parts are used, the manufacturer cannot guarantee safe operation of the device. The manufacturer or distributor cannot be held liable for any damage, injury or financial loss resulting from improper use.



Wear protective glasses when working on electrical connections.

DANGER!



Poisonous and hot gas hazard

When installing or removing the device, poisonous and hot gas can be released from the duct.



Wear appropriate respiratory and eye protection gear when installing or removing the device. Follow all applicable local and plant-specific safety codes before proceeding.

WARNING!



Risk of burns due to hot components

When installing or removing equipment, the device or the installation surface can be hot.



Wear appropriate heat-resistant gloves and follow all applicable local and plant-specific safety codes before proceeding.

WARNING!



Electric shock hazard

Faulty electrical installations, too high line voltage or incorrect operation of the device can result in an electric shock. Only trained and qualified personnel can install, commission, operate and perform maintenance on the device.

CAUTION!



Risk of burns due to hot components

When the device is connected to a stack and the sampling is active, the sensor probe and the internal piping heat up. Touching any of these parts when the sampling has been active can result in a burn. Wear appropriate heat-resistant gloves and let the sampling probe, nozzle and internal piping cool down before removing and performing maintenance on them.



To ensure that performing maintenance on the device is safe, keep the following points in mind:

- Power down the device when you are making electrical connections, when you intend to perform maintenance on it, or in the event of malfunction.
- Make sure that all equipment is properly grounded.
- Never perform maintenance on the device alone.

Make sure that an industry specialist inspects and approves the device for use in the monitoring system that the device is part of, and ensures that its use complies with all local safety standards and regulations.

12.2 Maintenance and inspection interval

The device requires minimum maintenance at normal operation with typical processes. It is recommended to visually inspect the optical XO sensor module weekly during the first 1-2 months of operation. If the signal levels have remained within the expected limits and all the other components of the sampling line (extraction system, heaters, air supplies, etc.) are working normally, the inspection and maintenance interval can be extended. See Table 15 for inspection and maintenance tasks and intervals.

Table 15: Maintenance tasks and intervals

Interval	Tasks
3 months	<ul style="list-style-type: none"> • Inspect and clean the sampling probe • Inspect and clean the optics of the XO sensor module • Inspect and clean the compressed air regulator unit • Inspect and clean the filters on the compressor, sample air blower and regulator unit. If necessary, replace the filters. • Inspect the operation of the sampling and purge air flow metering. • Inspect and clean the sampling flow measurement hoses.
12 months	<ul style="list-style-type: none"> • Inspect and clean the sampling and exhaust piping • Inspect and clean the ejector chamber.



If you notice that the device is not operating normally, contact the manufacturer or an authorized distributor.

12.3 Cleaning supplies

NOTICE

Do not use any abrasive material or corrosive substances to clean the device enclosure, sensor module or sampling probe. Doing so can damage the parts and affect the measurement results.

NOTICE

When cleaning the components inside the optical XO sensor module, be careful not to scratch any of the lenses. Damaged lenses will affect the measurement results.

Use the following supplies to clean the device and its parts:

- Use a cloth or paper towel to clean the device enclosure. If necessary, you can apply mild detergent or isopropyl alcohol to remove stuck-on dirt.
- Use a brass or steel tube brush to clean the inside of the sampling probe. If the inside of the probe is encrusted with burned particles to the point where it cannot be cleaned, the inner pipe must be replaced.
- Use a micro-fiber cloth, for example the kind used to clean camera lenses, or a soft optics cleaning brush to clean the optical components inside the sensor module.

12.4 Maintenance procedures

12.4.1 Filter locations

WARNING!



Risk of injury

If the device is powered ON, there is a risk of electric shock, burns or other injuries when touching the components inside the enclosure. Make sure that the device is turned OFF when inspecting and changing the filters.

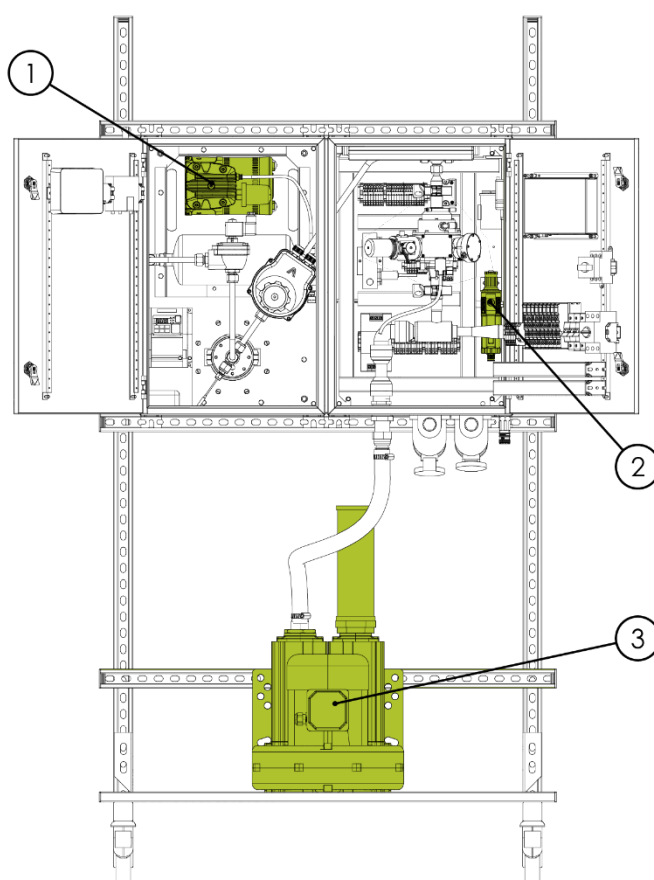

Figure 62: Locations of filters in the standard device

① Compressor	③ Sample air blower
② Regulator unit	

The device and its components contain various filters. The filters must be inspected and, if necessary, replaced every 3 months.

The following components of the device contain filters:

- Compressor unit
- Sample air blower
- Air regulator unit

If the device is equipped with the optional purge air blower, there are additional filters in the purge air blower and on the side of the device enclosure.

12.4.2 Optical XO sensor module

It is recommended to clean the optics of the sensor module every 3 months. To do this, you must remove the sensor module from the enclosure and detach the mirror chambers using quick-release levers.

Each mirror chamber is attached using two quick-release levers. To use a quick-release, gently pull on the knob and turn the lever into the slot next to it.

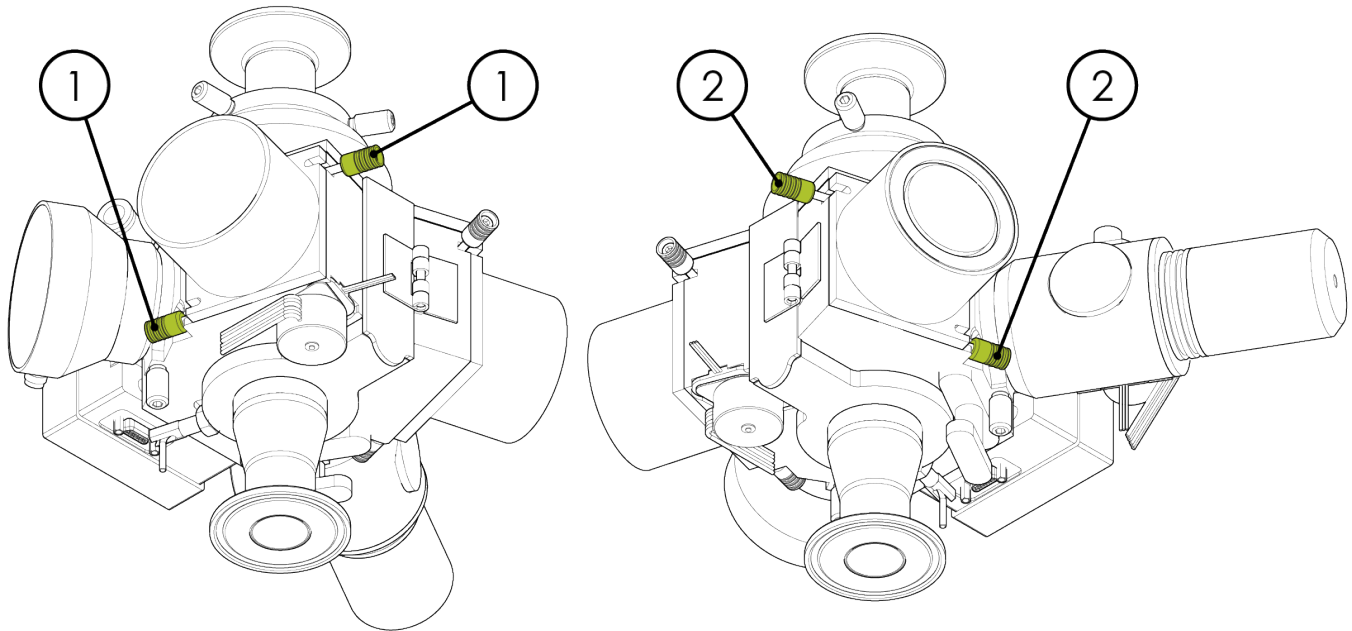
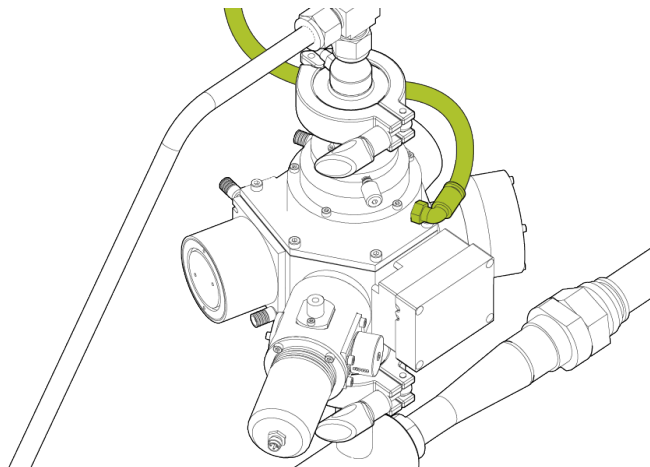

Figure 63: Location of quick-release levers on the optical XO sensor module

-
- | | |
|--|---|
| ① Quick-release levers for the mirror chamber located next to the scattered light detector | ② Quick-release levers located next to the LED light source |
|--|---|
-

To clean the optical XO sensor module:

1. Turn the main power switch to OFF position and disconnect the power supply cable.
2. Disconnect the signal cables from the connector housing and pre-amplifier.
3. Disconnect the purge air hose from the sensor module.



4. Hold the module in place with one hand. Use your other hand to remove the quick-clamp connectors that secure the sensor module to the internal piping and ejector chamber.

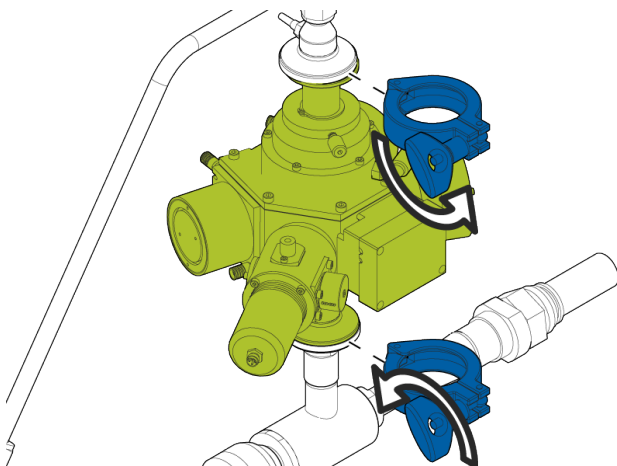

5. Remove the sensor module from the device enclosure. Retain the quick-clamp gaskets.

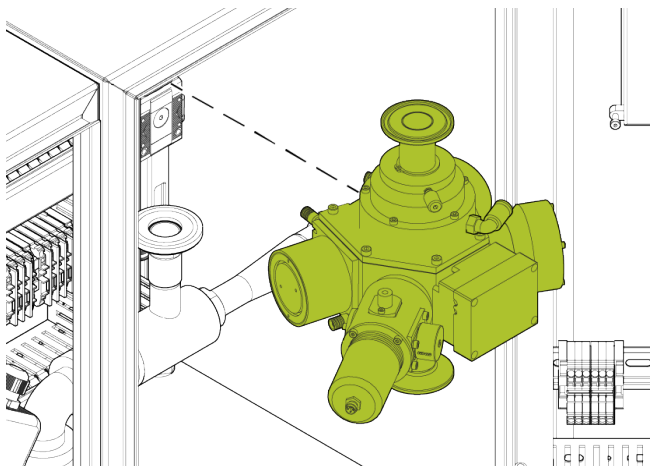

6. Take the sensor module to a dust-free and well-lit location.
7. Use the quick-release levers to remove individual chambers from the sensor module one at a time.
 - Clean the optics carefully using a micro-fiber cloth or a soft optics cleaning brush.
 - When you are done, attach the mirror chamber back to the module.

When you have completely cleaned the sensor module:

8. Install the module as instructed in section **Installing optical XO sensor module** in chapter **Mechanical installation**.
9. Connect the cables to the connector housing and pre-amplifier as instructed in section **Connections on sensor module** in chapter **Electrical installation**.
10. Turn the main power switch to ON position.

12.4.3 Sampling probe



To perform maintenance on the sampling probe, you must first remove the optical XO sensor module from the enclosure. See section “Optical XO sensor module” in this chapter for instructions on how to remove the sensor module from the enclosure.

It is recommended to clean the inner pipe of the sampling probe every 3 months. To do this, you must remove the probe from the stack and disconnect it from the device enclosure.

To remove the sampling probe from the enclosure for cleaning, you need:

- Wrench (22 mm [0.866 in])

To clean the sampling probe:

1. Turn the main power switch to OFF position and disconnect the power supply cable.
2. Remove the optical XO sensor module from the enclosure. See **Optical XO sensor module** in this chapter for instructions.
3. Disconnect the thermocouple and heater connections from the terminal blocks inside the device enclosure. See Figure 27 in chapter **Electrical installation** for their location on the terminal blocks.
4. Loosen the hex nuts on the internal piping using a wrench.

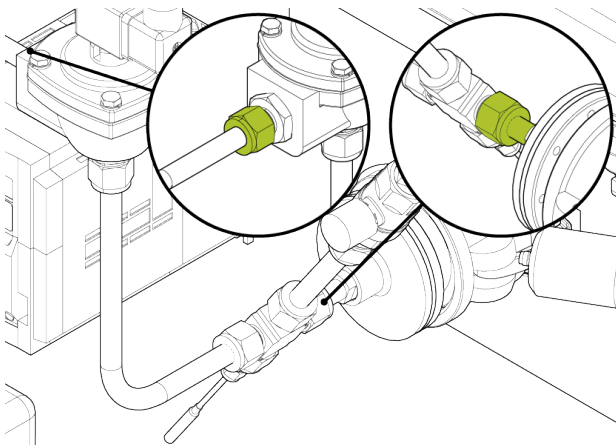

5. Move the internal piping out of the way so you can remove the sampling probe. You do not need to take the piping out of the enclosure.

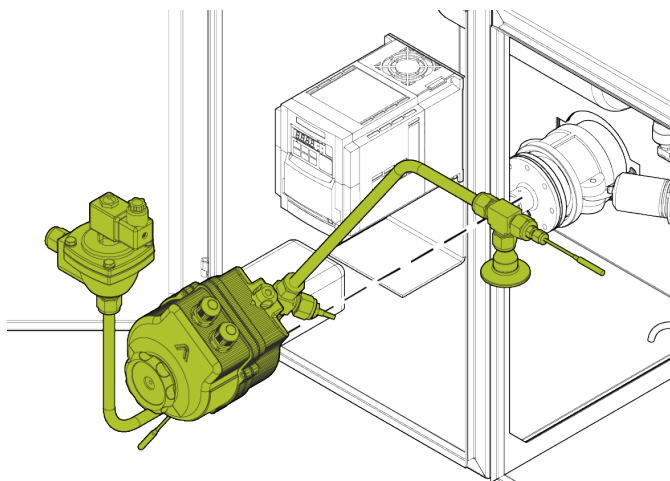

6. Release the locking mechanism and remove the sampling probe from the device enclosure.

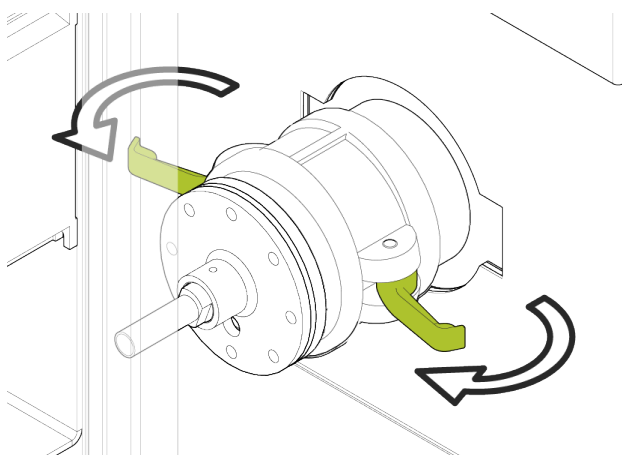

7. Disconnect the nozzle by loosening the fastening nut located at its base.

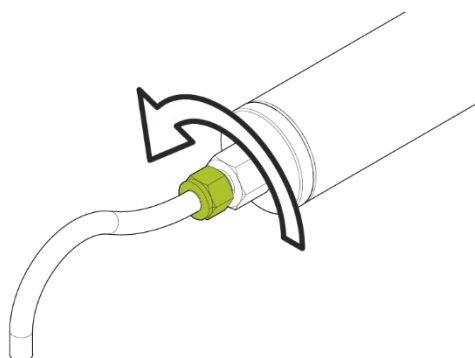

8. Inspect the inner pipe by looking inside the probe. You should be able to see through it.
9. Clean the inner pipe with a brass or steel tube brush.

10. When you have cleaned the inner pipe, attach the nozzle by tightening the fastening nut located at its base.

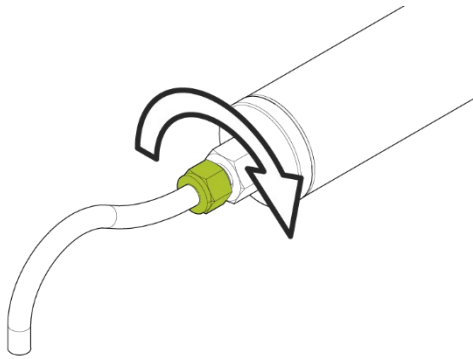

- 11. Install the sampling probe to the device enclosure as instructed in section **Connecting sampling probe to enclosure** in chapter **Mechanical installation**.
- 12. Connect the cables to the sampling probe as instructed in section **Connections on sampling probe** in chapter **Electrical installation**.
- 13. Turn the main power switch to ON position.

12.4.4 Ejector chamber



To perform maintenance on the ejector chamber, you must first remove the optical XO sensor module from the enclosure. See section “Optical XO sensor module” in this chapter for instructions on how to remove the sensor module from the enclosure.

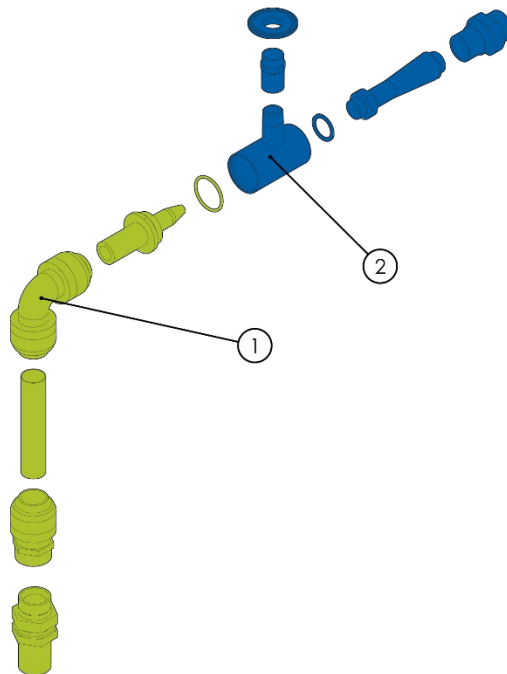

Figure 64: Ejector chamber assembly

① Sample blower side

② Exhaust side

It is recommended to inspect the inside of the ejector chamber every 6-12 months. To do this, you must first remove the sensor module from the device enclosure and then disconnect the ejector chamber from the surrounding pipes.

To remove the ejector chamber for cleaning, you need:

- Adjustable wrench

To inspect and clean the ejector chamber:

1. Turn the main power switch to OFF position and disconnect the power supply cable.
2. Disconnect the tube fittings on the side and bottom of the enclosure by loosening the hex nuts that secure them to the enclosure.
 - Use one wrench to hold the inner components in place and prevent them from rotating.
 - Loosen the nut on the tube fitting with another wrench.

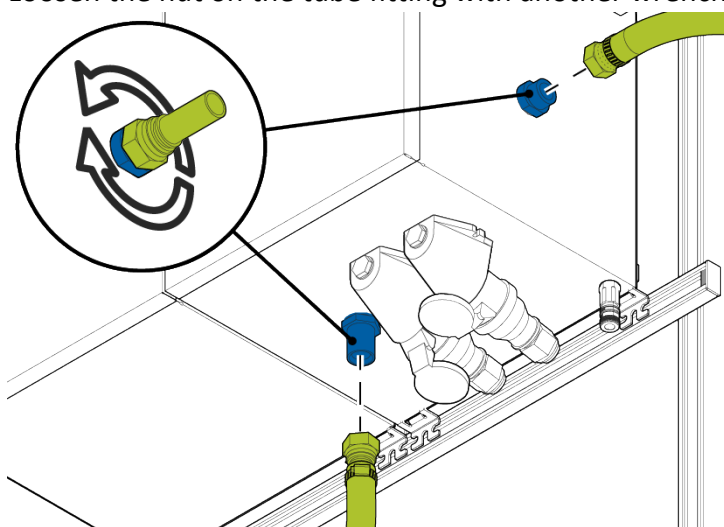

3. Remove the tube fitting connectors on the side and bottom of the enclosure by loosening the hex nuts that secure them to the enclosure.
 - Use one wrench to hold the inner components in place and prevent them from rotating.
 - Loosen the nut on the tube fitting connector with another wrench.

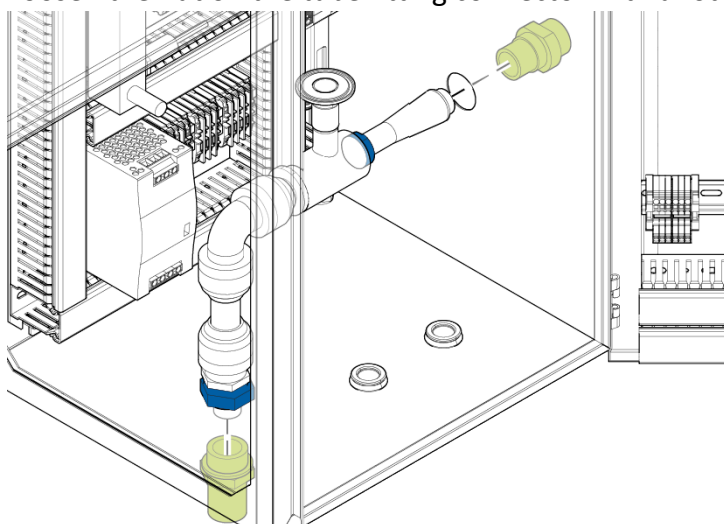

4. You can now remove the ejector chamber from the enclosure.

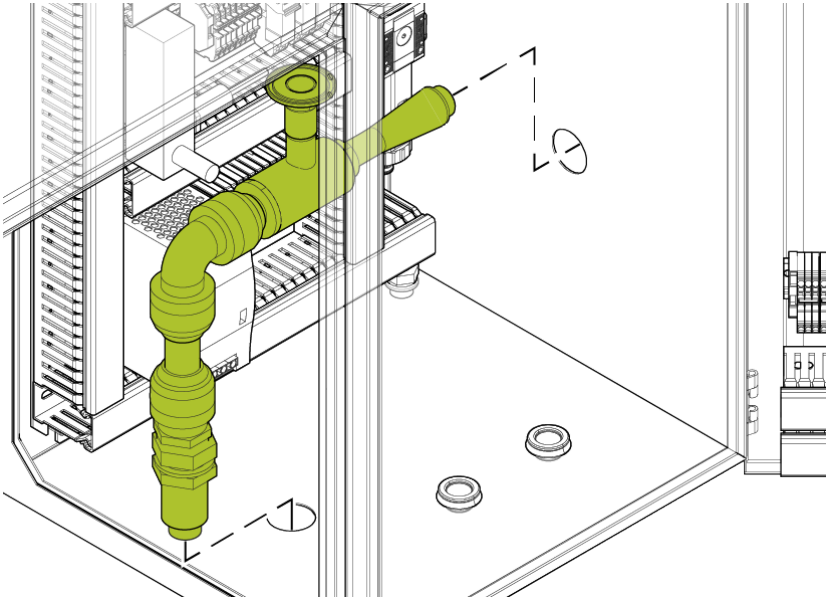

5. Disassemble the ejector chamber assembly.

- Inspect the inside of the ejector chamber and the adjacent pipes.
- Clean the components, for example with a soft brush.

6. After you have inspected and cleaned the ejector chamber, assemble the ejector chamber.

7. Insert the ejector chamber assembly back into the enclosure.

8. Install the tube fitting connectors the side and bottom of the enclosure and connect them to the ejector chamber assembly. Tighten the hex nuts that secure the connectors to the enclosure.

- Use one wrench to hold the inner components in place and prevent them from rotating.
- Tighten the nut on the tube fitting connector with another wrench.

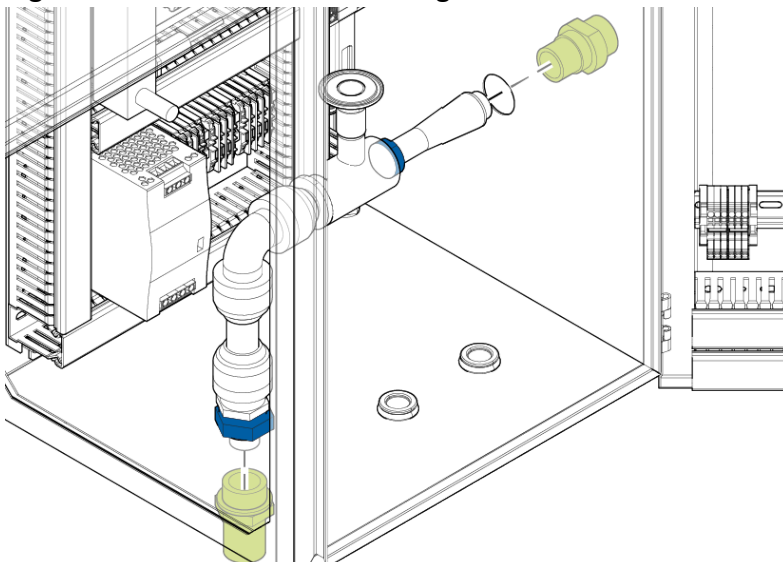

9. Connect the tube fittings to the side and bottom of the enclosure by tightening the hex nuts that secure them to the enclosure.
- Use one wrench to hold the inner components in place and prevent them from rotating.
 - Tighten the nut on the tube fitting with another wrench.

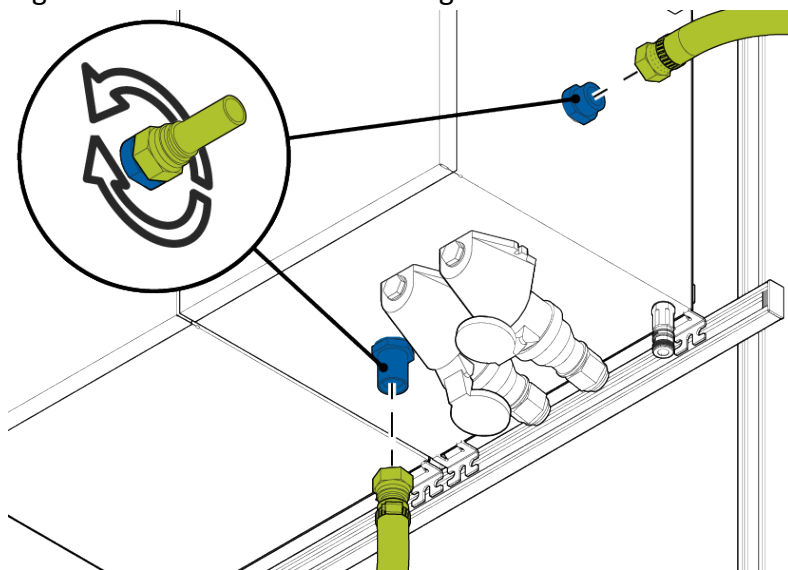

10. Install the sensor module as instructed in section **Installing optical XO sensor module** in chapter **Mechanical installation**.
11. Connect the signal cables to the sensor module as instructed in section **Connections on sensor module** in chapter **Electrical installation**.
12. Turn the main power switch to ON position.

12.4.5 Internal piping of the sampling line



To perform maintenance on the internal piping of the sampling line, you must first remove the optical XO sensor module from the enclosure. See section “Optical XO sensor module” in this chapter for instructions on how to remove the sensor module from the enclosure.



When you remove the internal piping from the enclosure for maintenance and inspection, you must disconnect the valve cables from the terminal blocks.

The recommended inspection interval for the internal piping that carries the sample gas is 6-12 months.

To remove and disassemble the internal piping from the enclosure for cleaning, you need:

- Wrench (22 mm [0.866 in])

To inspect and clean the internal piping, you must disassemble the piping assembly. Pressure vessel side of the internal piping is in contact with only clean air, so it does not require cleaning. Sampling side of

the internal piping carries the sample gas to the optical XO module, so it is in constant contact with dirty and dusty air.

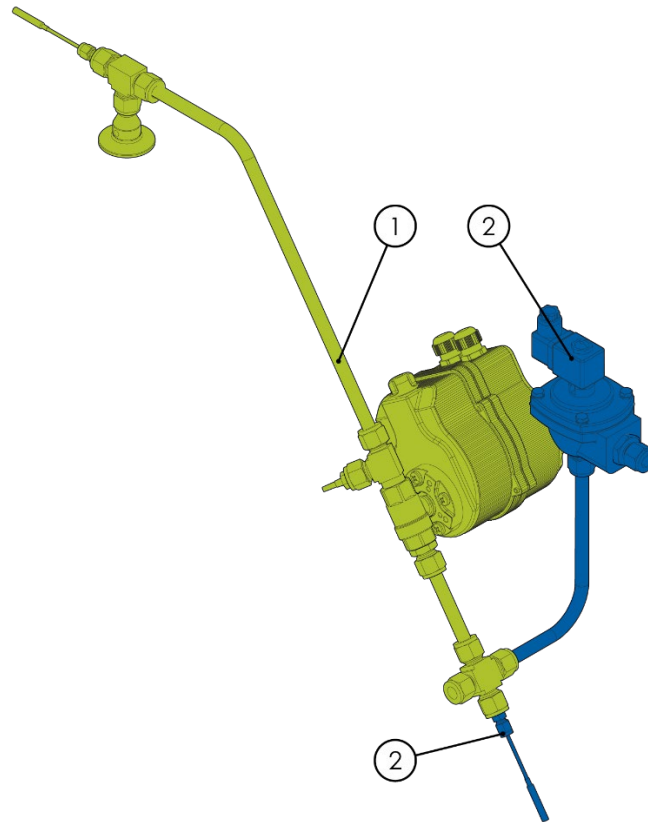

Figure 65: Internal piping assembly

① Sampling side

② Pressure vessel side

When you remove the internal piping from the enclosure, you must disconnect the valve connections on the terminal block. The terminals are located on the top rail in the right half of the enclosure.

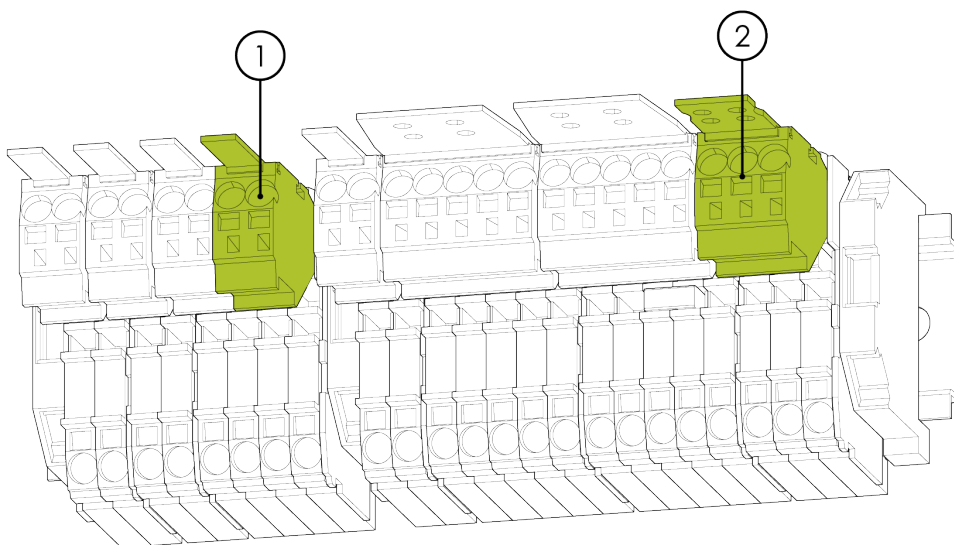

Figure 66: Valve connections on the terminal block

① Flue gas valve

② Cleaning pulse valve

To clean the internal piping:

1. Turn the main power switch to OFF position and disconnect the power supply cable.
2. Disconnect the flue gas valve and cleaning pulse valve connections from the terminal blocks inside the device enclosure.
3. Loosen the hex nuts on the internal piping using a wrench.

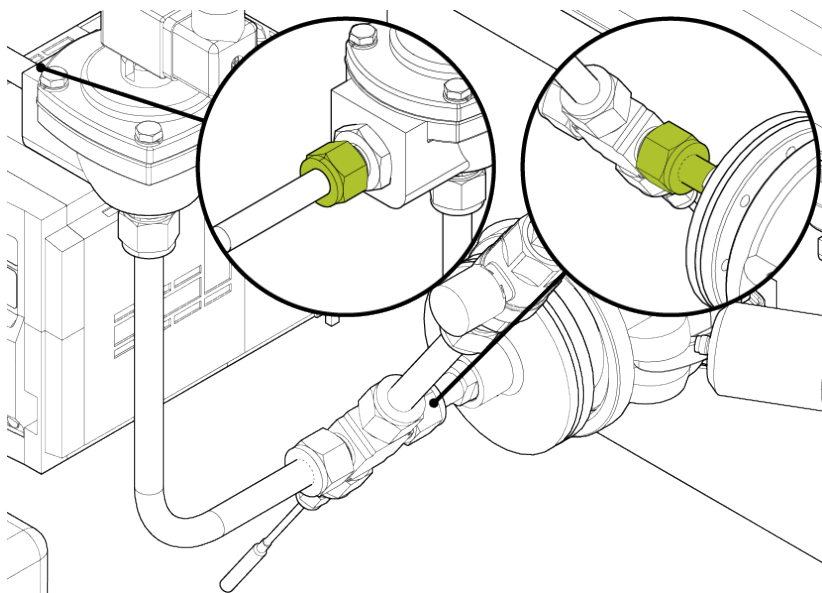

4. Remove the internal piping from the enclosure.

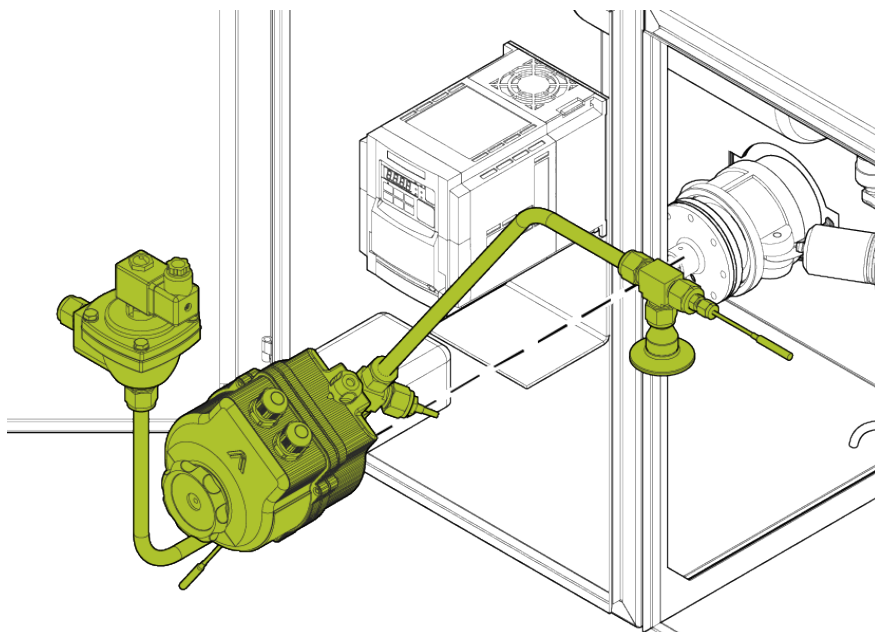

5. Disassemble the internal piping.
 - Inspect and clean the sampling side piping that carries the sample gas into the optical XO module.
 - Pressure vessel side of the internal piping assembly requires little to no cleaning because it is in only contact with clean air.

6. After you have inspected and cleaned the internal piping, assemble the piping.
7. Secure the internal piping back to the sampling probe and pressure vessel by tightening the hex nuts.

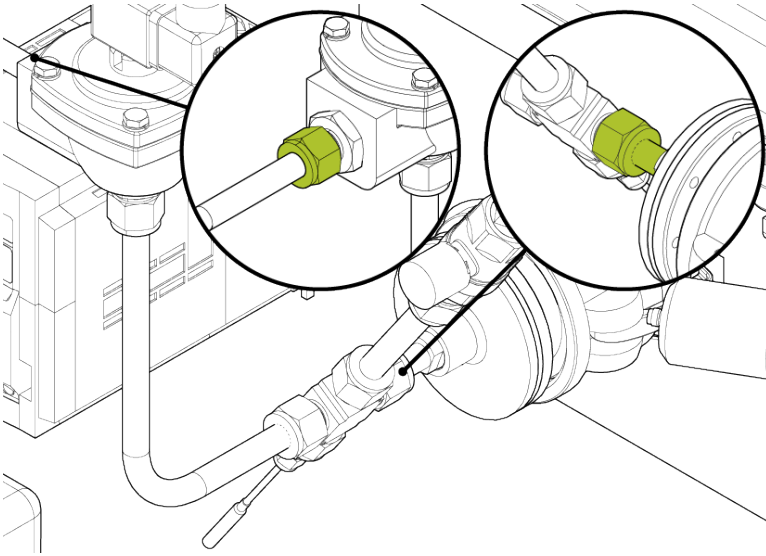

8. Reconnect the valve cables to the terminal blocks.

12.4.6 Operation of sampling flow measurement

To confirm the correct operation of the sampling flow measurement:

1. Stop sampling from the MAIN view of the device.
2. Shut down the sample air blower.
3. Check the flow value in Sampling view or Sampling settings. The value should be 0.

12.4.7 Sampling flow measurement hoses

If you suspect that the sampling flow measurement is showing incorrect value, you must disconnect the hoses between the measurement points and the differential pressure transmitter.

To disconnect the sampling flow measurement hoses:

1. Turn the main power switch to OFF position and disconnect the power supply cable.

2. Disconnect the hoses from the flow measurement points on the sampling line.

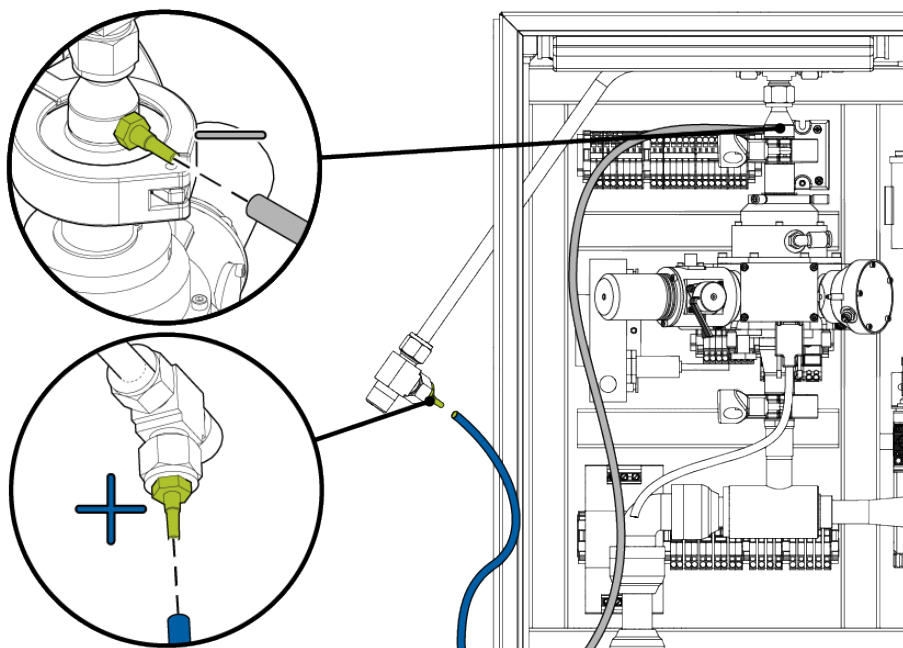

3. Disconnect the hoses from the pressure transmitter.

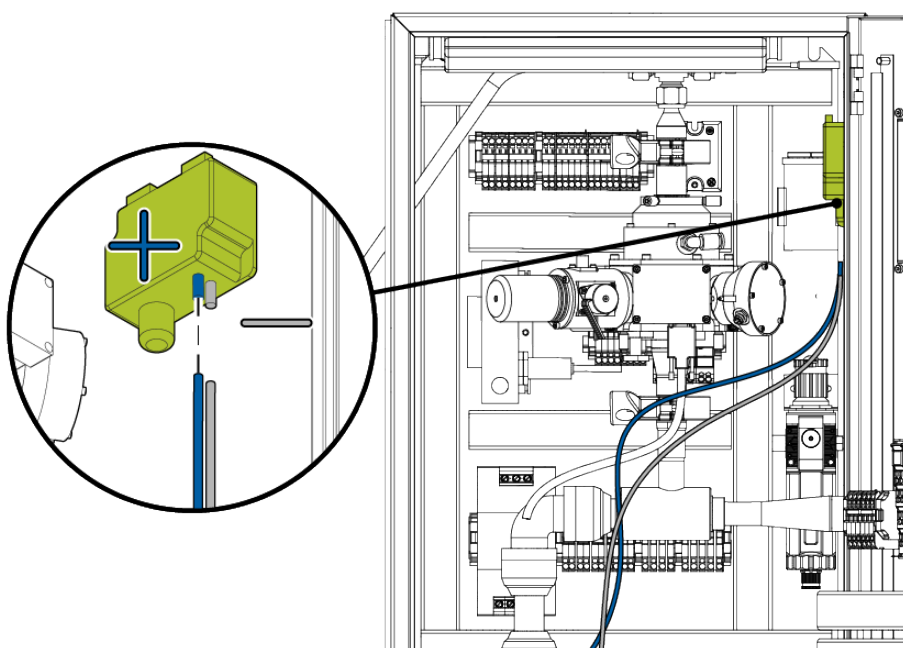

4. Inspect the hoses for damage or blockages. Replace the hoses if necessary.

12.4.8 Operation of purge air flow measurement

To confirm the correct operation of the sampling flow measurement:

1. Stop sampling from the MAIN view of the device.
2. Stop purge air flow.
3. The proximity sensor connected to the rotameter should activate digital output 8.



12.5 Returns

If you need to return a defective device for repair, replacement or disposal, contact the manufacturer or an authorized distributor. Return the device in its original packaging, or in a suitable secure container.

Contact details for the manufacturer's offices are available on the back cover of this user manual, and online at <https://sintrol.com/contact/>.

13 Recycling and disposal

13.1 Packaging



Recycle any paper, cardboard or plastic material used in the product packaging, and sort them in an appropriate recycling container.

Any non-recyclable packaging material must be disposed of with general waste.

13.2 Device



Electronic devices that are marked with this symbol must not be disposed of with general or household waste. If a defective or broken-down device cannot be repaired, it must be recycled and disposed of in accordance with WEEE directive (2012/19/EU) or other applicable local regulations.

14 Technical data

14.1 Dimensions

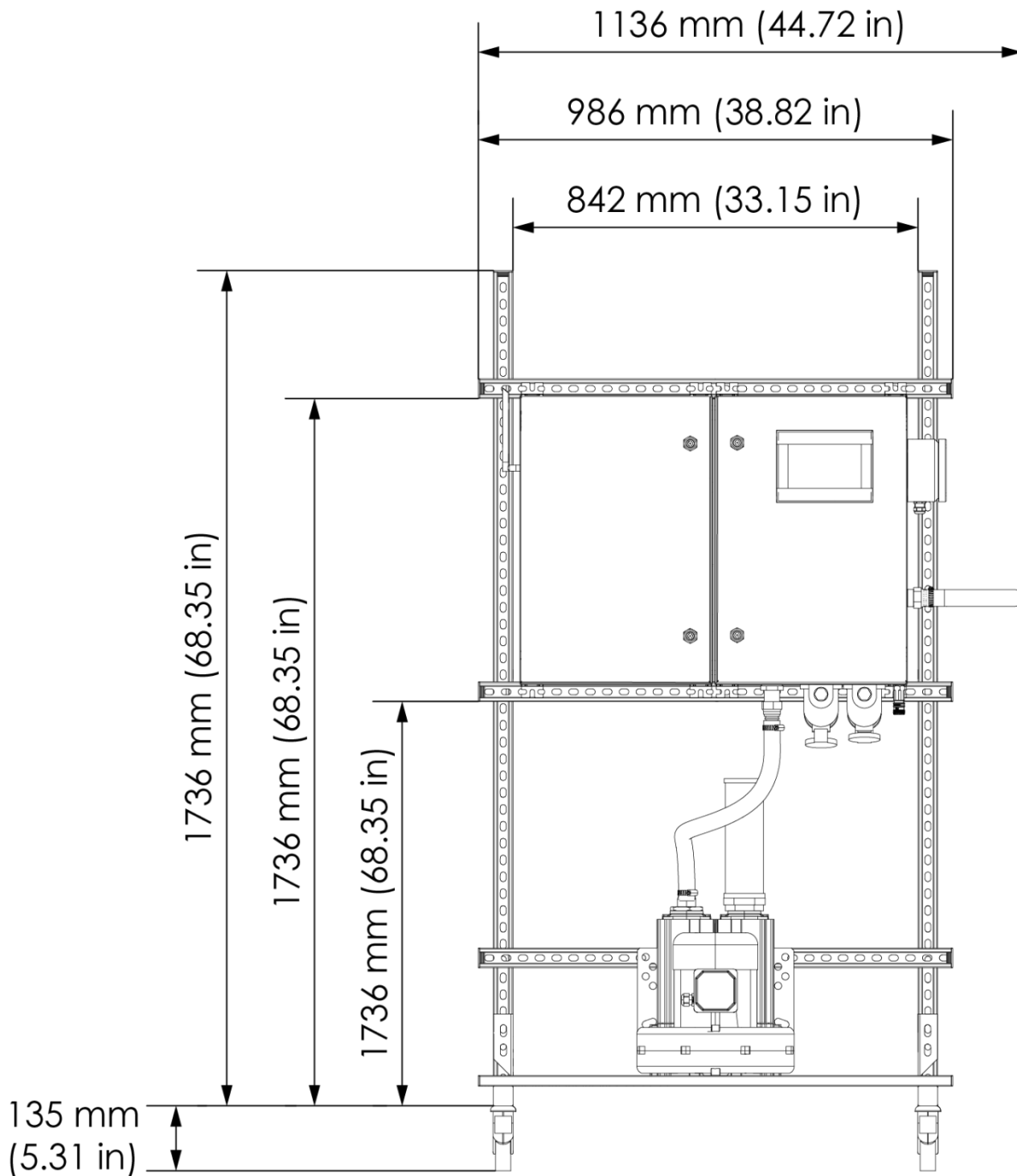

Figure 67: Front view of the fully assembled dust monitor setup.

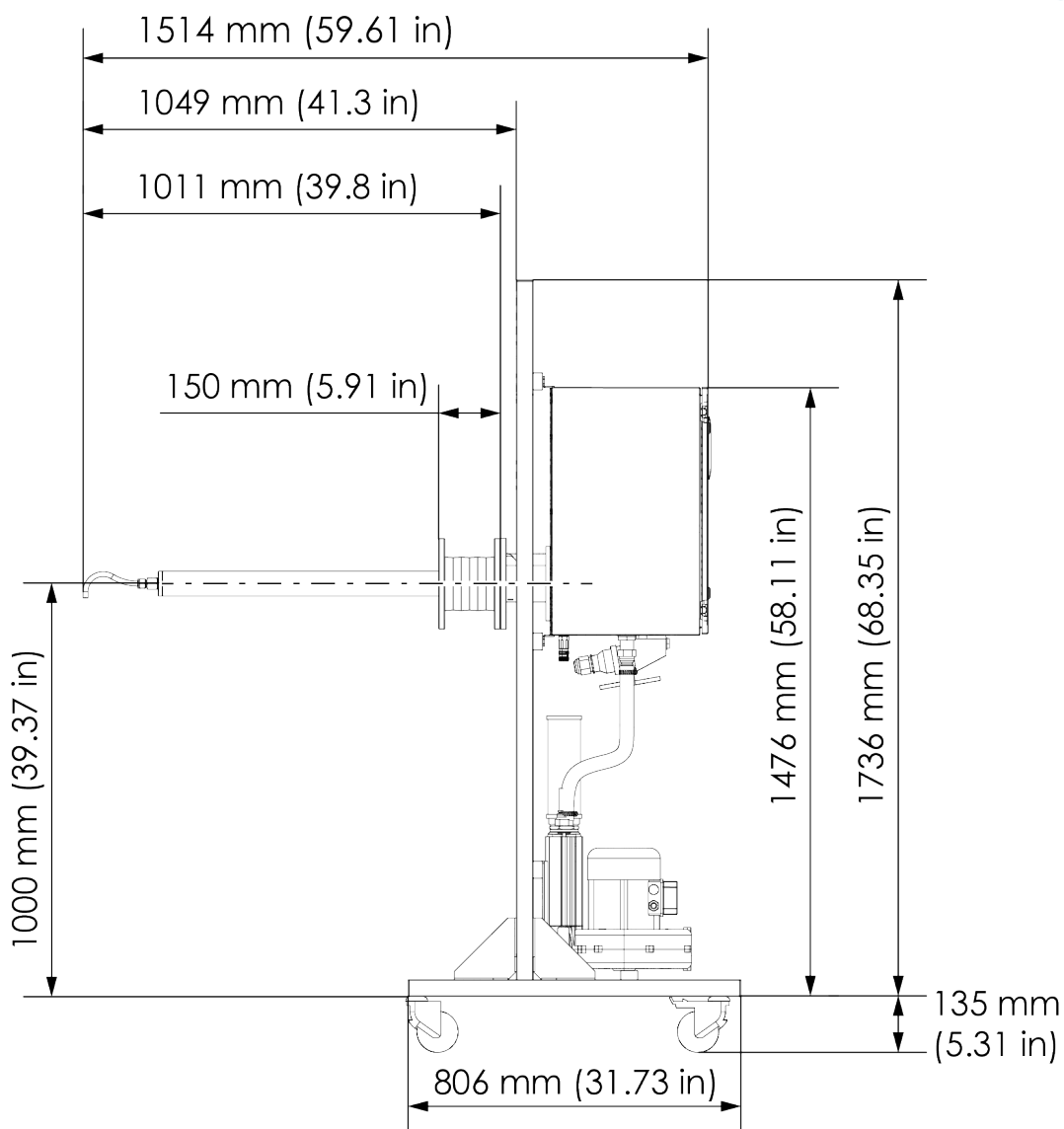

Figure 68: Side view of the full dust monitoring system

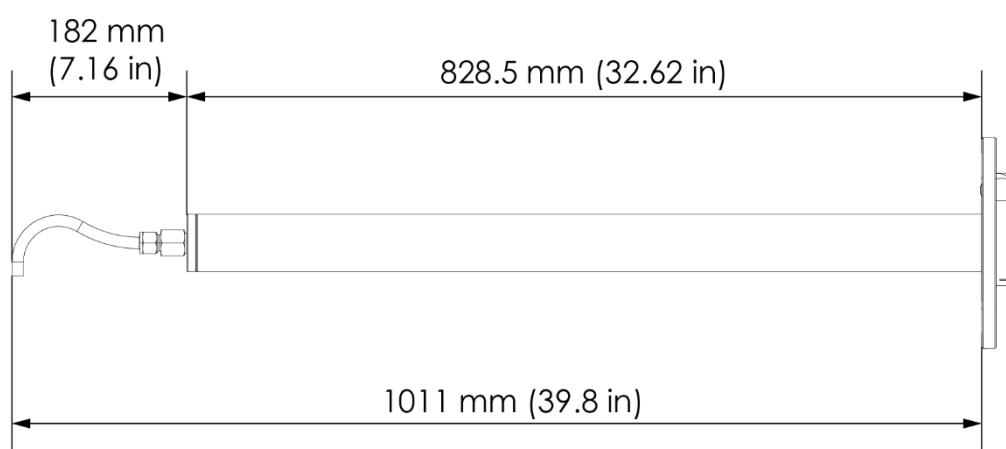

Figure 69: Sampling probe

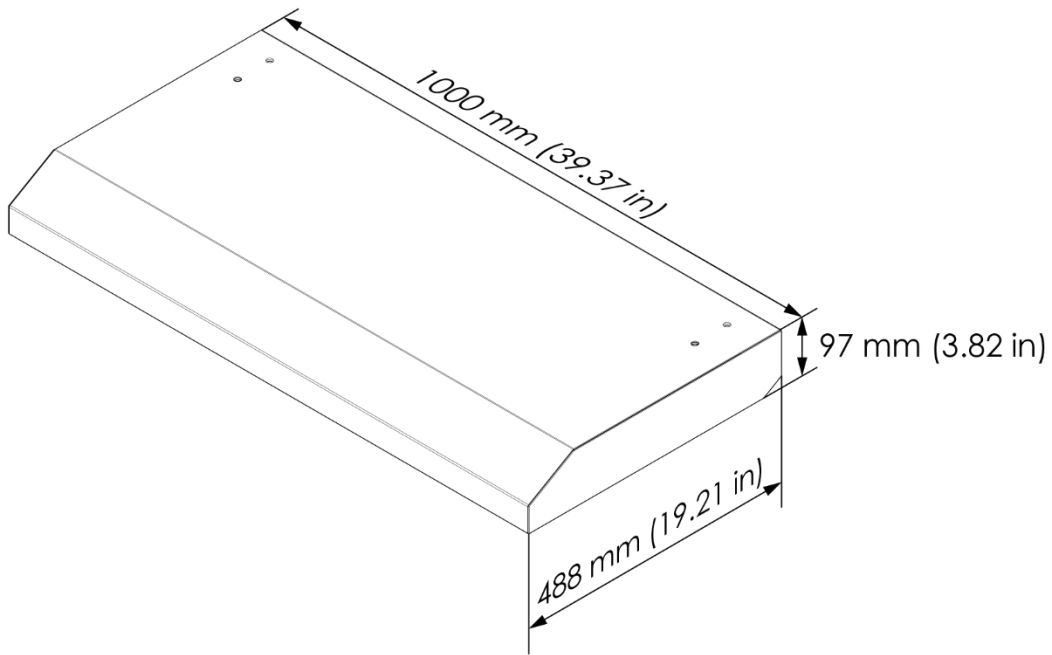

Figure 70: Weather protection roof for outdoor installations

14.2 Clearances

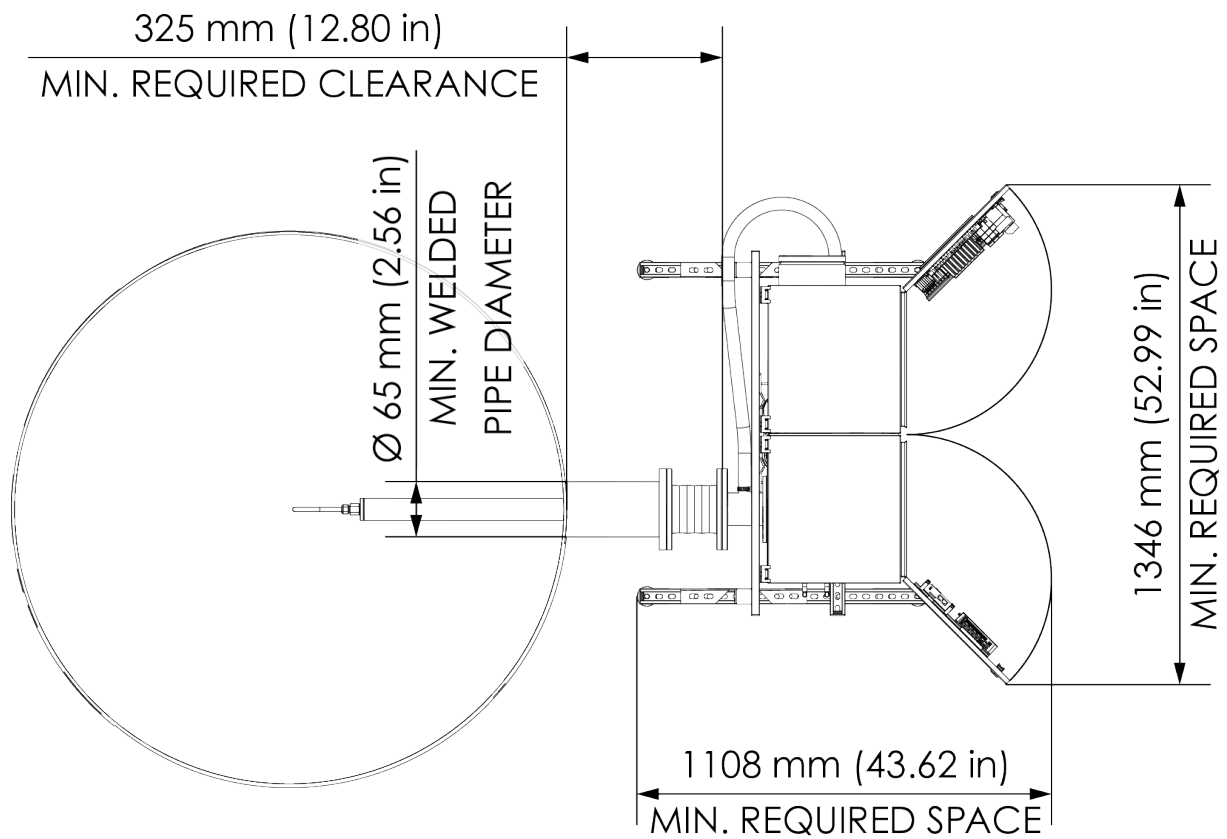

Figure 71: Minimum clearances around the device

14.3 Specifications

General information

Product name:	EXO
Measured objects:	Total suspended particles (TSP)
Measurement principle:	Optical forward scattering
Measurement range:	Detection limit 0.01 mg/m ³ Max. range up to 500 mg/m ³
Ingress protection:	IP54
Power supply requirements:	400 V 3 Phase / 16 A, 50 Hz
Power consumption:	<ul style="list-style-type: none"> • Heaters and auxiliaries: < 2 kW • Sample air blower: < 2.2 kW
Output signals:	<ul style="list-style-type: none"> • 2 × 8 Digital outputs, 24 V DC / 0.5 A • Isolated active 4 ... 20 mA output loop, max. loop resistance 350 Ω • Ethernet TCP/IP for remote control • USB for data logging

Physical characteristics

Enclosure:	Powder coated steel
Sensor module:	Anodized aluminum
Wetted parts:	<ul style="list-style-type: none"> • Probe: Stainless steel (316L), optionally Hastelloy C276 • Internal piping: Stainless steel (316L)
Weight:	Approx. 120 kg (265 lbs)

Ambient conditions

Temperature:	-40 ... 50 °C (-40 ... 122 °F)
Humidity:	Max. 95 % relative humidity

Process conditions

Temperature:	Max. 300 °C (572 °F)
Flow velocity:	5 ... 25 m/s (16.40 ... 82.02 ft/s)



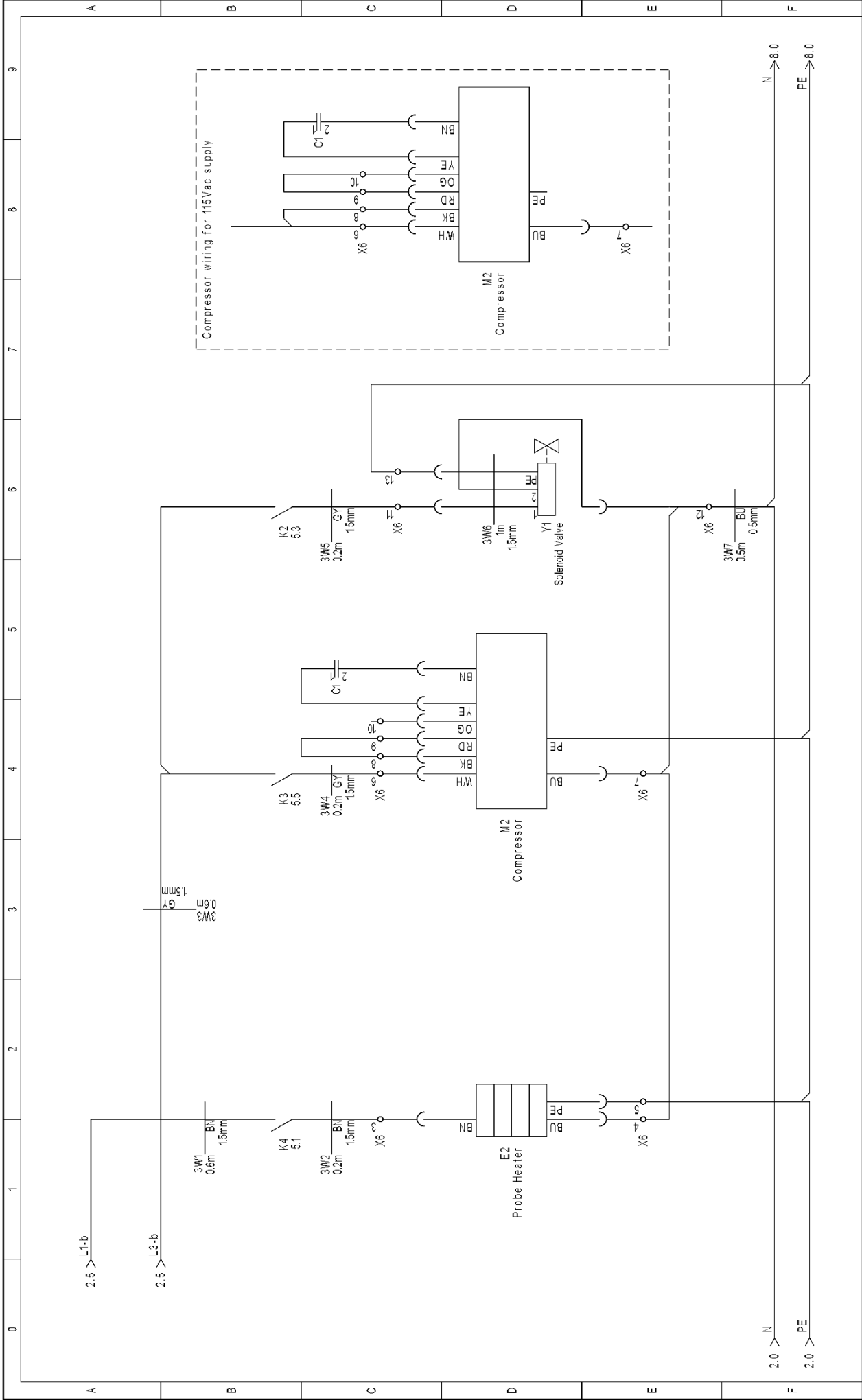

Appendix A: ISO 9001 certificate

Visit <https://sintrol.com/company/> for the latest ISO 9001 certificate.

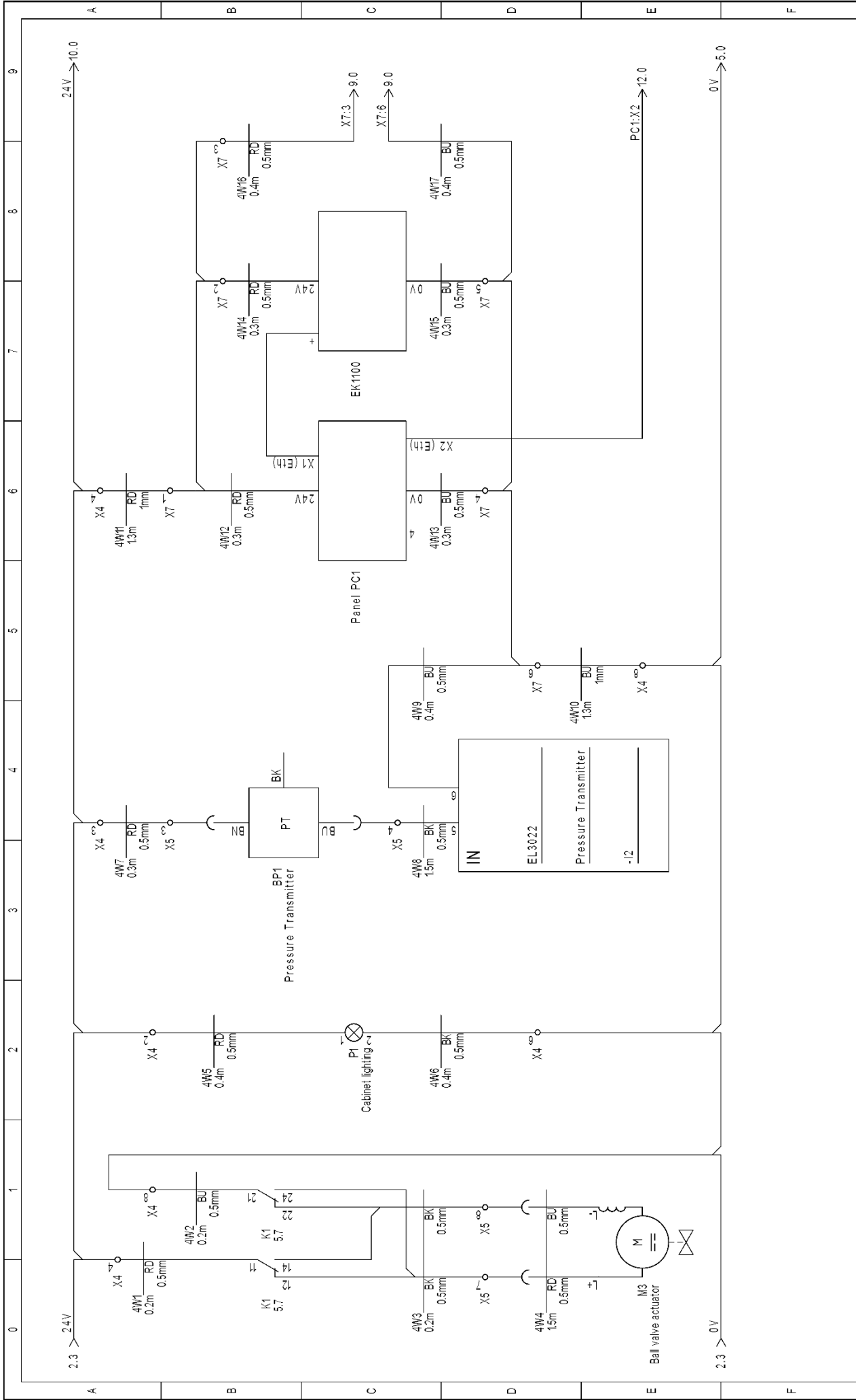

	EXO Extractive dust measurement	Compressor and Probe Heater		Project: EXO - Wiring diagram	Drawing no.:	Created by: ALDE	Rev: 1	Sheet: 3
				Date: 16/02/2022	Function:	Location:	Total sheets: 12	Next sheet: 4



	EXO Extractive dust measurement	24V connections	Project: EXO - Wiring diagram	Drawing no.: 1	Created by: ALDE	Rev.: 1	Sheet: 4
			Date: 16/02/2022	Function: 12	Location: 5	Total sheets: 12	Next sheet: 5

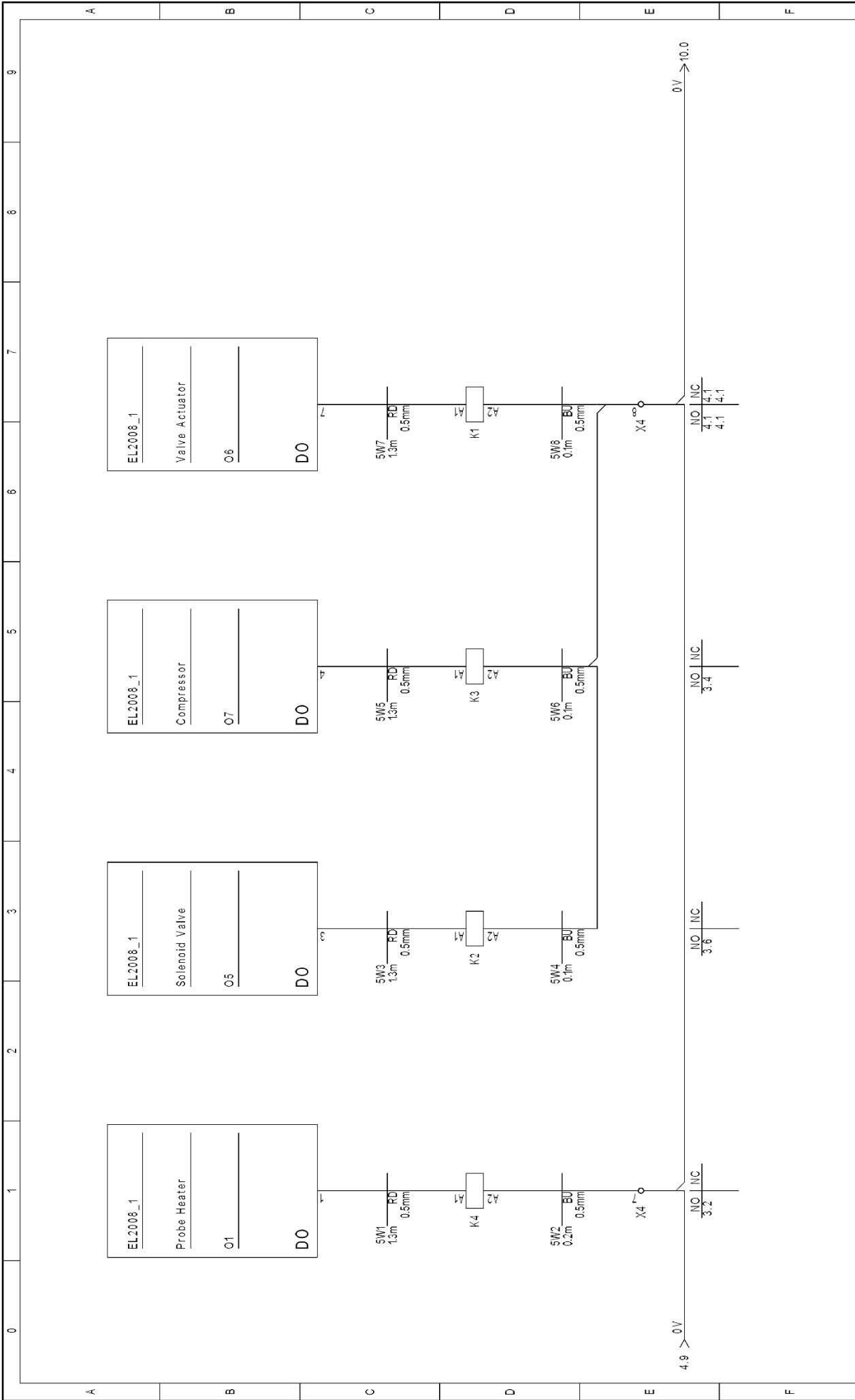

	EXO Extractive dist measurement	PLC Digital Outputs	Project: EXO - Wiring diagram Date: 16/02/2022	Drawing no.: Function:	Created by: ALDE Location:	Rev: 1 Total sheets: 12	Sheet: 5 Next sheet: 6
---	---------------------------------	---------------------	---	---------------------------	-------------------------------	----------------------------	---------------------------

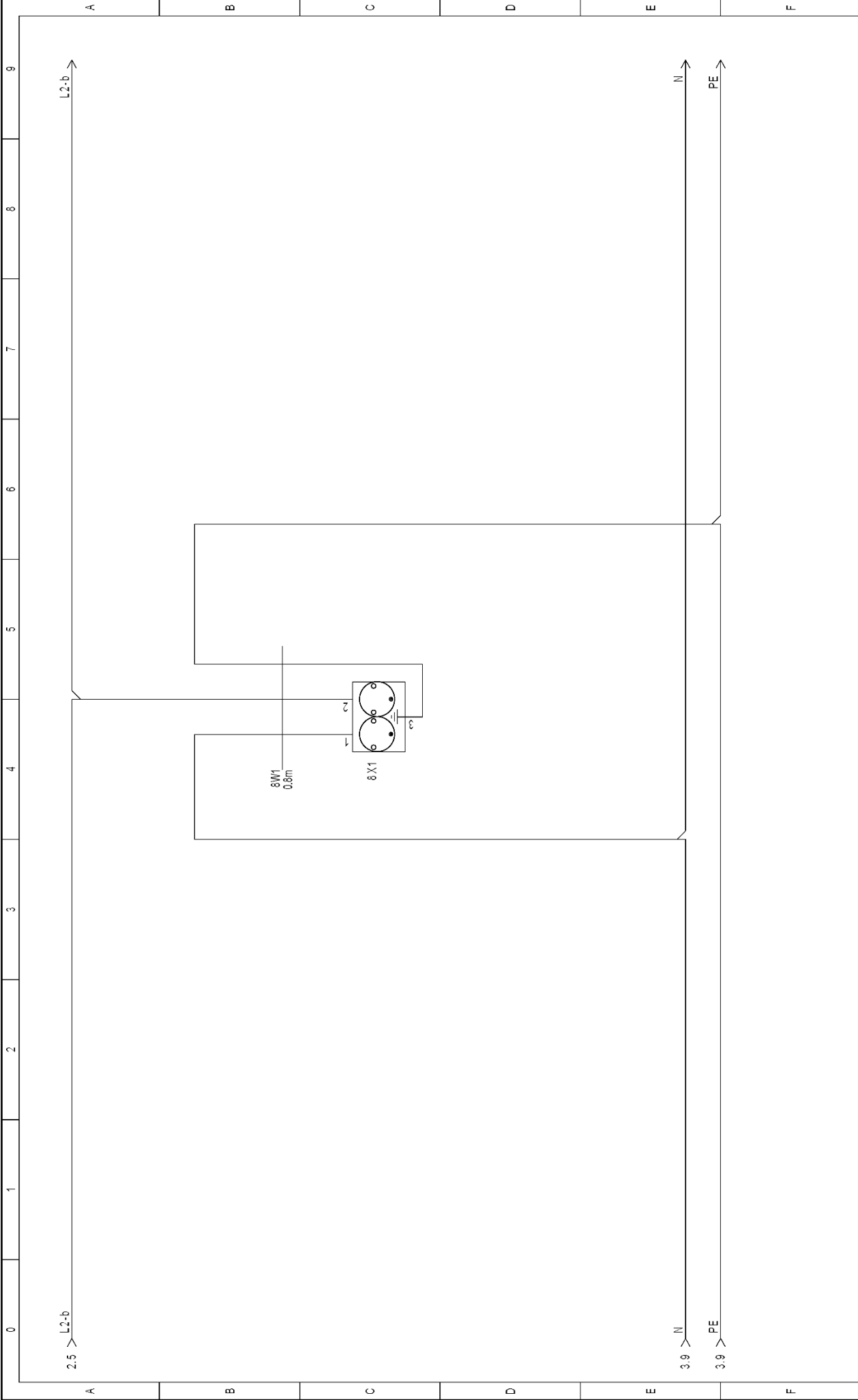

	EXO, Extractive dust measurement	Power Socket	Project: EXO - Wiring diagram	Drawing no.: 	Created by: ALDE	Rev.: 1	Sheet: 8
			Date: 16/02/2022	Function: 	Location: 	Total sheets: 12	Next sheet: 9

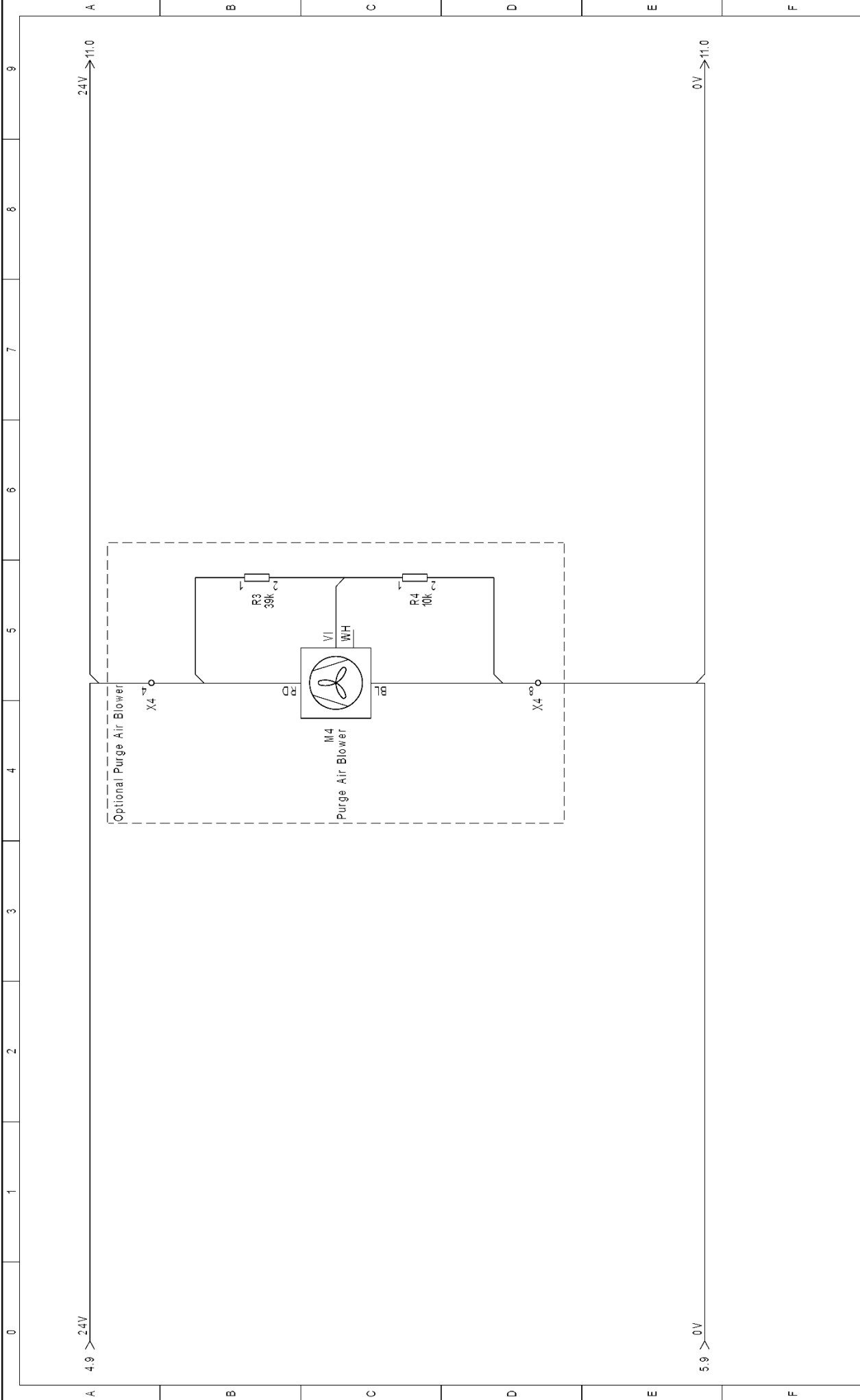

	EXO, Extractive dust measurement	Optional Purge Air Blower	Project: EXO - Wiring diagram	Drawing no.: Function:	Created by: ALDE	Rev.: 1	Sheet: 10
			Date: 16/02/2022	Location:		Total sheets: 12	Next sheet: 11

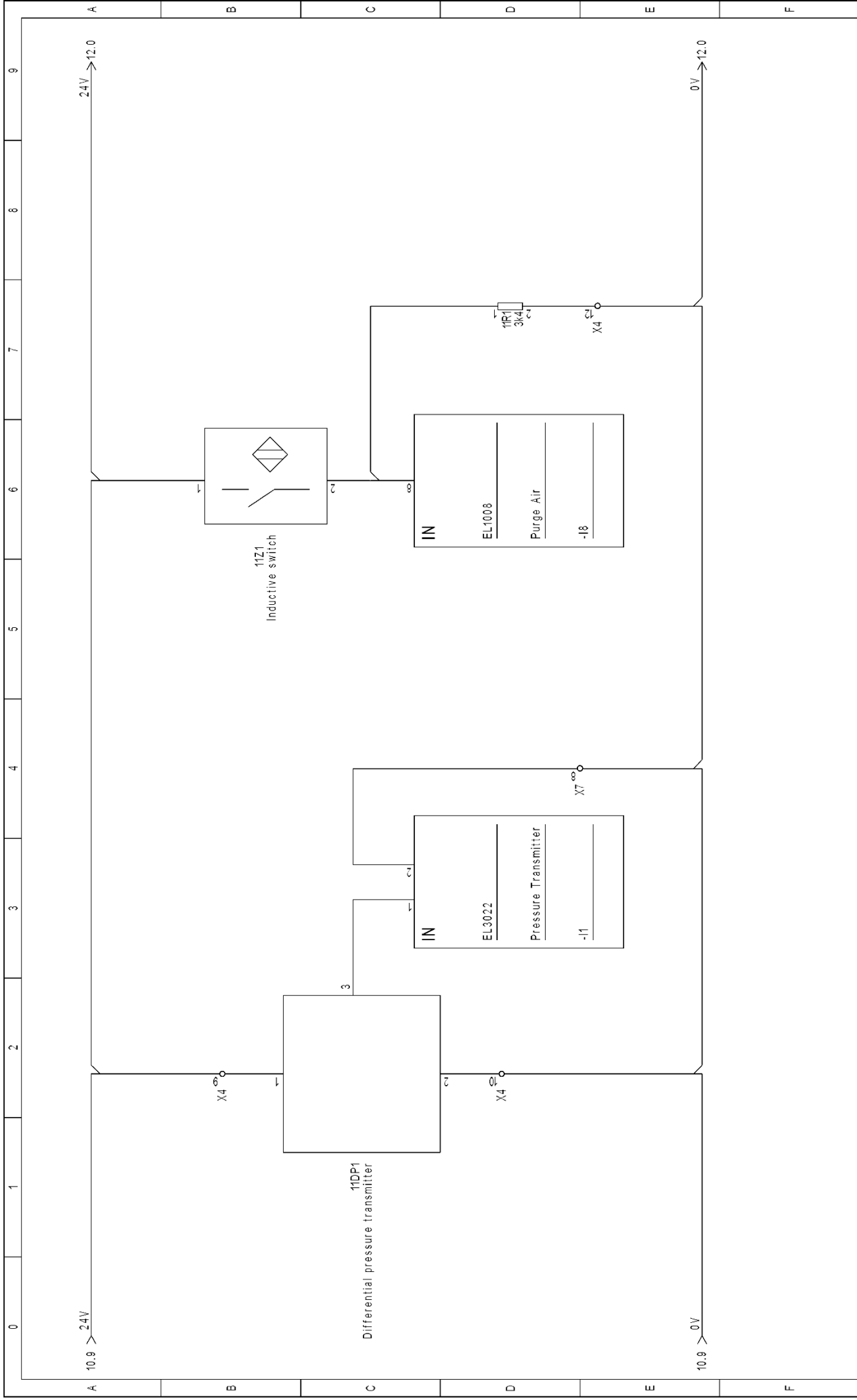

 SINTROL <small>For Good Measure</small>	EXO Extractive dust measurement	QAL Version	Project: EXO - Wiring diagram	Drawing no.: Function:	Created by: ALDE	Rev.: 1	Sheet: 11
			Date: 16/02/2022	Location:	Total sheets: 12	Next sheet: 12	

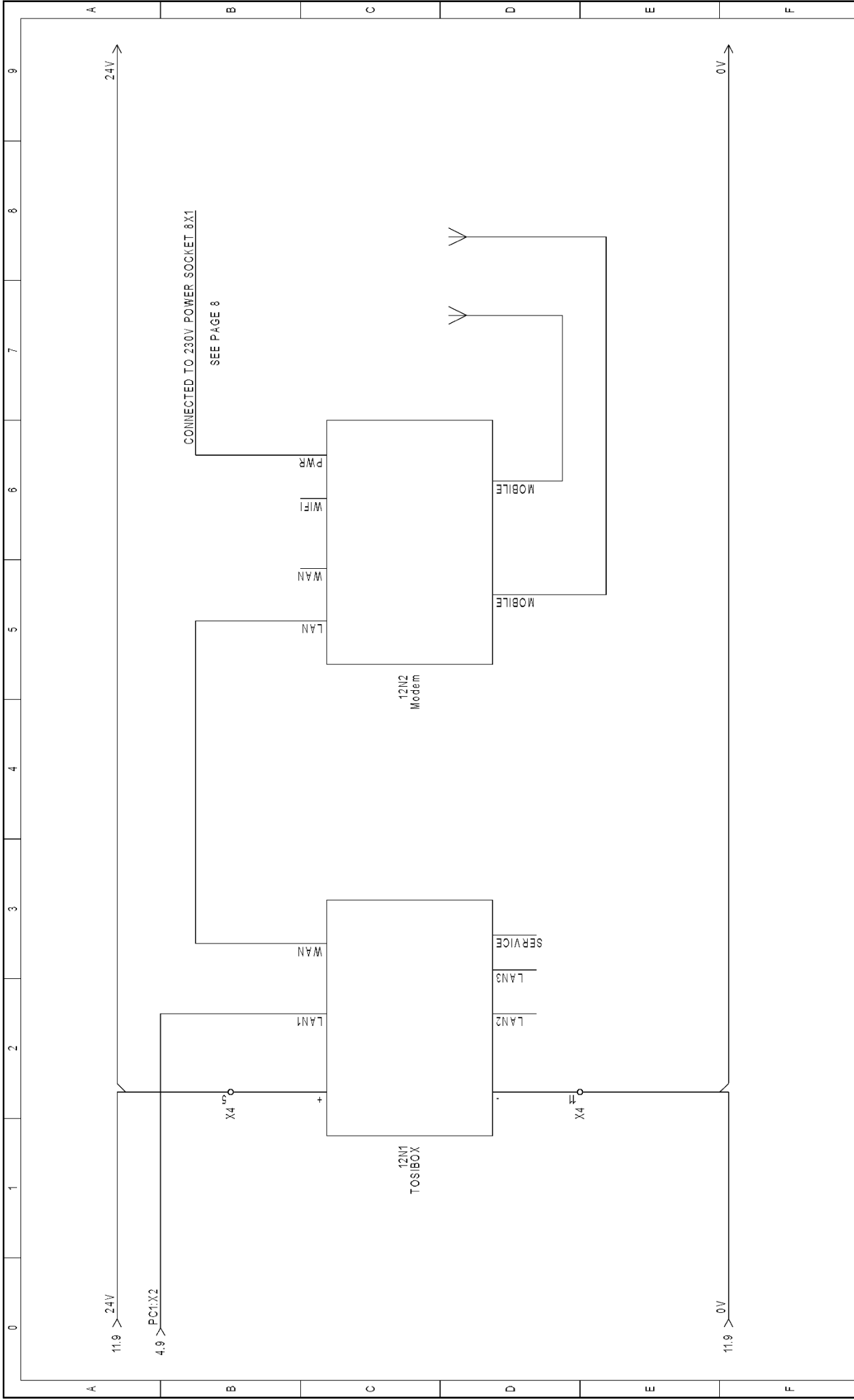

	EXO, Extractive dust measurement		Remote Connection		Project: EXO - Wiring diagram	Drawing no.:	Created by:	Rev.:	Sheet:
					Date:	Function:	Location:	Total sheets:	Next sheet:
				16/02/2022				1	12
								12	12



Contact us

FINLAND WORLDWIDE

Helsinki
Tel. +358 9 561 7360
info@sintrrol.com
www.sintrrol.fi
www.sintrrol.com

INDIA Representative office

New Delhi
Tel. +91 98 1167 6061
india@sintrrol.com

CHINA Representative office

Beijing
Tel. +86 10 8788 8681
china@sintrrol.com
cn.sintrrol.com

JAPAN Representative office

Tokyo
Tel. +81 90 8585 1301
japan@sintrrol.com

<https://sintrrol.com/>
<https://sintrrol.com/contact/>



Subject to change without notice.
All rights reserved. © 2024 Sintrol

Revision 3
2024-11-20